

BEST PRACTICES for:

Carbon Storage Systems and Well Management Activities



April 2012



Disclaimer

This report was prepared as an account of work sponsored by an agency of the United States Government. Neither the United States Government nor any agency thereof, nor any of their employees, makes any warranty, express or implied, or assumes any legal liability or responsibility for the accuracy, completeness, or usefulness of any information, apparatus, product, or process disclosed, or represents that its use would not infringe privately owned rights. Reference therein to any specific commercial product, process, or service by trade name, trademark, manufacturer, or otherwise does not necessarily constitute or imply its endorsement, recommendation, or favoring by the United States Government or any agency thereof. The views and opinions of authors expressed therein do not necessarily state or reflect those of the United States Government or any agency thereof.

Best Practices for Carbon Storage Systems and Well Management Activities

DOE/NETL-2011/1458

April 2012

National Energy Technology Laboratory
www.netl.doe.gov



Table of Contents

List of Figures	vi
List of Tables	vii
List of Acronyms and Abbreviations	viii
Executive Summary	1
1.0 Introduction	3
2.0 Refining a Detailed Site Development Plan	6
2.1 Assess Initial Site Characterization	7
2.2 Injection Design	8
2.2.1 Injection Field Layout	8
Existing Wells	8
Well Design and Spacing	8
2.2.2 Facility Design	9
2.3 Project Cost Revisions	9
2.4 Permitting	12
2.4.1 Injection Well Permitting	12
2.4.2 Additional Permits	13
2.4.3 Supporting Project Plans	14
Produced Water	14
Closure and Post-Injection Monitoring	14
Mitigation	14
3.0 Site Preparation	15
3.1 Establishing Site Security and Access	16
3.2 Well and Facility Layout	16
3.2.1 Topographic Survey	17
3.2.2 Geotechnical Survey	17
3.2.3 Environmental Assessment	17
3.2.4 Well Location Considerations	17
3.2.5 Planning Surface Equipment Configuration	18
3.3 Well Pad Preparation	19
3.4 Typical Facility Layouts	19
3.4.1 Examples of Small-Scale Injection Layout	21

4.0 Drilling and Completion Operations	25
4.1 Well Drilling	26
4.1.1 Equipment	26
4.1.2 Drilling Methods	29
<i>Percussion Drilling</i>	29
<i>Rotary Drilling</i>	30
<i>Auger Drilling</i>	31
<i>Coiled Tubing</i>	31
<i>Slimhole Drilling</i>	31
4.1.3 Drilling Fluids	31
4.1.4 Materials Handling	32
<i>Drilling Fluids</i>	33
<i>Waste Water</i>	33
<i>Produced Water</i>	33
<i>Drill Cuttings</i>	33
4.1.5 Potential Drilling Issues	33
4.2 Formation Evaluation	34
4.2.1 Logging	34
4.2.2 Coring	38
<i>Coring Techniques</i>	38
4.2.3 Drill Stem Testing	39
4.2.4 Reservoir Fluid Testing	39
4.2.5 Open-Hole Testing	40
4.2.6 Evaluating the Suitability of the Formation	40
4.3 Well Construction	40
4.3.1 Casing Strings	40
4.3.2 Cementing	42
4.3.3 Wellheads	42
4.4 Well Testing	43
4.5 Determining the Suitability of a Well	44
5.0 Injection Operations	45
5.1 Pre-Injection Baseline Monitoring	45
5.2 Injection System Completion	45
5.2.1 Standard Equipment	45
<i>CO₂ Pipelines</i>	47
<i>Compression/Dehydration System</i>	48

Valves	48
CO ₂ Injection Control and Monitoring Equipment	49
CO ₂ Leak Alarms	49
Collection Ports	50
Support Buildings	50
5.3 Additional Considerations	50
5.3.1 Enhanced Coalbed Methane (ECBM)	50
5.3.2 Enhanced Oil Recovery (EOR) CO ₂ Floods	50
5.3.3 Produced Water	51
5.4 Injection	51
5.4.1 Startup Operations	51
5.4.2 Routine Injection	52
CO ₂ Injection Procedures	52
Monitoring	52
5.4.3 Routine Field Operations	52
Well Field Optimization	52
Well Integrity	53
6.0 Post-Injection Operations	55
6.1 Post-Injection MVA	57
6.2 Well Closure	57
6.2.1 Well Plugging and Abandonment Methodologies	58
6.3 Site Closure	61
7.0 Conclusion	61
References	62
Appendix A – Compilation of Key Well Drilling and Construction Information for RCSP Test Sites	69
Appendix B – Sample Authority for Expenditure (AFE) Form from Petroleum Industry	73
Appendix C – UIC Program Contact Information by State	74
Appendix D – Oil and Gas Contact Information by State	80
Appendix E – References for Different Aspects of Well Drilling and Construction	88
Appendix F – Produced Water Disposal Options	91
Contacts	93

List of Figures

Figure 1-1: Overview of Major Well Management Activities by Stage of Project Development	5
Figure 2-1: Key Aspects to Refine in the Detailed Site Development Plan	6
Figure 2-2: UIC Permitting Authority for UIC Class I-V	12
Figure 3-1: Generalized Flow Diagram Illustrating the Site Preparation Process	15
Figure 3-2: Example of a Facility Layout During Drilling	19
Figure 3-3: Example of an Injection Well	20
Figure 3-4: Example of a Groundwater Monitoring Well	20
Figure 3-5: Example of Injection Equipment	21
Figure 3-6: Side View of Injection Equipment Layout at MGSC Tanquary CO ₂ Injection Pilot Project	22
Figure 3-7: Aerial View of Injection Equipment Layout at MGSC Tanquary CO ₂ Injection Pilot Project	23
Figure 3-8: Injection Equipment Arrangement for East Bend CO ₂ Test	24
Figure 4-1: Key Steps and Decisions in Drilling and Well Completion Process	25
Figure 4-2: Example of a Mud Rotary Drilling Rig	27
Figure 4-3: Drill Collars Which Provide Drilling Stability and Weight to the Drill String	28
Figure 4-4: Fixed Cutter Drilling Bits	30
Figure 4-5: Example of Tricone Rotary Drill Bit	30
Figure 4-6: Various Fishing Tools that May be Used to Retrieve Lost Tools	34
Figure 4-7: Example of an Open-Hole Wireline Log	36
Figure 4-8: Example of Open Hole Logs Used to Construct a Cross Section	37
Figure 4-9: Core Bits	38
Figure 4-10: Example of a Multiple Cased Well	42
Figure 4-11: Example of an Injection Wellhead Assembly	43
Figure 4-12: Example of a Monitoring Wellhead Assembly	43
Figure 4-13: Example of a Processed CBL-VDL Log	44

Figure 5-1: Standard Injection Equipment _____	46
Figure 5-2: CO ₂ Injection Wellhead with Emergency Shutdown (ESD) Valve _____	47
Figure 5-3: MGSC Decatur Site Phase III Compression/Dehydration System _____	48
Figure 5-4: Typical Valves Found in an Injection Wellhead Assembly _____	49
Figure 5-5: Examples of Various Field Monitoring Techniques _____	53
Figure 6-1: Flow Diagram of Post-Injection Operations for a CO ₂ Injection Project _____	55
Figure 6-2: Stages in a CCS Project _____	56
Figure 6-3: Depiction of MRCSP Phase II Test Well Following Plugging and Abandonment _____	60

List of Tables

Table 2-1: Major Cost Elements by Project Stage _____	10
Table 2-2: Typical Injection Permit Information Provided by RCSPs _____	13
Table 4-1: Common Drilling Methods _____	29
Table 4-2: Residual Waste Management Considerations _____	32
Table 4-3: Some Examples of Open-Hole Logs Performed by RCSP Projects _____	35
Table 4-4: API and ASTM Well Construction Specifications _____	41

List of Acronyms and Abbreviations

<u>Acronym/Abbreviation</u>	<u>Definition</u>
°C _____	Degree Celsius
°F _____	Degree Fahrenheit
3-D _____	Three-Dimensional
AFE _____	Authorization for Expenditure
ANL _____	Argonne National Laboratory
AoR _____	Area of Review
API _____	American Petroleum Institute
ASTM _____	American Society for Testing and Materials
bbbl _____	Barrel
BLM _____	Bureau of Land Management
BOPs _____	Blowout Preventers
BPM _____	Best Practice Manual
Btu _____	British Thermal Units
CBL _____	Cement Bond Log
CCS _____	Carbon Capture and Storage
CEQA _____	California Environmental Quality Act
CF _____	Certification Framework
CFR _____	Code of Federal Regulations
CH ₄ _____	Methane
CLR _____	CO ₂ Leakage Risk
CO ₂ _____	Carbon Dioxide
CT _____	Coiled Tubing
DCNR _____	Department of Conservation and Natural Resources
DOE _____	U.S. Department of Energy
DOT _____	Department of Transportation
DST _____	Drill Stem Test
ECBM _____	Enhanced Coalbed Methane
EIA _____	Energy Information Administration
EOR _____	Enhanced Oil Recovery
EPA _____	U.S. Environmental Protection Agency
EPRI _____	Electric Power Research Institute
ESD Valve _____	Emergency Shutdown Valve
ESP _____	Electric Submersible Pump
FEED _____	Front End Engineering and Design
FEPs _____	Features, Events, and Processes
FHWA _____	Federal Highway Administration
FS _____	Forestry Service

<u>Acronym/Abbreviation</u>	<u>Definition</u>
ft _____	Feet
ft ³ _____	Cubic Feet
gallons/yd ² _____	Gallons per Square Yard
GHG _____	Greenhouse Gas
GIS _____	Geographical Information System
GS _____	Geologic Storage
H ₂ S _____	Hydrogen Sulfide
HAZOP _____	Hazardous Operations
HFC _____	Hydrofluorocarbon
IOGCC _____	Interstate Oil and Gas Compact Commission
kHz _____	Kilohertz
l/m ² _____	Liters per Square Meter
LIDAR _____	Light Detection and Ranging
LS _____	Limited Service
m _____	Meter
mcf _____	Thousand Cubic Feet
mg/l _____	Milligrams per Liter
MGSC _____	Midwest Geologic Sequestration Consortium
MIT _____	Mechanical Integrity Test
MRCSP _____	Midwest Regional Carbon Sequestration Partnership
MRR _____	EPA Mandatory Greenhouse Gas Reporting Rule
Mud _____	Drilling Fluid
MVA _____	Monitoring, Verification, and Accounting
MWD _____	Measurement While Drilling
MWh _____	Megawatt Hours
N ₂ O _____	Nitrous Oxide
NO ₂ _____	Nitrogen Dioxide
NACE _____	National Association of Corrosion Engineers
NATCARB _____	National Carbon Sequestration Database and Geographic Information System
NEPA _____	National Environmental Policy Act
NETL _____	National Energy Technology Laboratory
NGO _____	Non-Governmental Organization
NPDES _____	National Pollutant Discharge Elimination System
O&M _____	Operation and Maintenance
OBMs _____	Oil-Based Muds
PCOR _____	Plains CO ₂ Reduction Partnership
PDC _____	Polycrystalline Diamond Compact

<u>Acronym/Abbreviation</u>	<u>Definition</u>
ppg _____	Pounds per Gallon
ppm _____	Parts per Million
psi _____	Pounds per Square Inch
PSInSAR _____	Permanent Scatterer Interferometric Synthetic Aperture Radar
PTFE _____	Polytetrafluoroethylene (Teflon)
RAS _____	Risk Analysis and Simulation Manual
R&D _____	Research and Development
RCSPs _____	Regional Carbon Sequestration Partnerships
ROI _____	Return on Investment
SO ₂ _____	Sulfur Dioxide
SBMs _____	Synthetic-Based Muds
SCF/d _____	Standard Cubic Feet per Day
SECARB _____	Southeast Regional Carbon Sequestration Partnership
SEM _____	Scanning Electron Microscopy
SHPO _____	State Historic and Preservation Office
SP _____	Spontaneous Potential
SPT _____	Standard Penetration Test
SSIC _____	Site Screening, Site Selection, and Initial Characterization
SWP _____	Southwest Regional Partnership on Carbon Sequestration
TDSs _____	Total Dissolved Solids
TIW _____	Texas Iron Works
U.S. _____	United States
UIC _____	Underground Injection Control
UNEP _____	United Nations Environment Programme
USDW _____	Underground Source of Drinking Water
USGS _____	U.S. Geological Survey
VDL _____	Variable Density Log
WAG _____	Water Alternated with Gas
WBMs _____	Water-Based Muds
WCI _____	Well Construction and Intervention
WESTCARB _____	West Coast Regional Carbon Sequestration Partnership
XRD _____	X-Ray Diffraction
XRF _____	X-Ray Fluorescence
XXHD _____	Extra Heavy Duty
γ _____	Gamma
μm _____	Micrometer

Executive Summary

Carbon dioxide (CO₂) capture and storage (CCS) is one of several promising emission-reduction strategies that can be used to help stabilize and reduce CO₂ emissions in the atmosphere while maintaining America's energy independence. The U.S. Department of Energy's (DOE) National Energy Technology Laboratory (NETL) has been actively researching and developing CCS technologies. The purpose of the DOE Carbon Storage Program is to demonstrate that CO₂ can be economically, successfully, and securely stored permanently in a manner that is compliant with the best engineering and geological practices; Federal, state, and local regulations; and in the best interests of local and regional stakeholders.

In a typical CCS project, CO₂ is captured at an anthropogenic source, transported to a suitable location, and injected into deep geologic formations for permanent storage in saline and hydrocarbon bearing formations. Wells are a critical component of any CCS project; they will be drilled and completed for multiple purposes, including: exploring the suitability of geologic formations; injecting CO₂; monitoring the behavior and location of injected CO₂; and, in the case of CO₂ utilization through enhanced oil recovery (EOR), producing hydrocarbons from the injection zone.

The purpose of this report is to share lessons learned regarding site-specific management activities for carbon storage well systems. This manual builds on the experiences of the Regional Carbon Sequestration Partnerships (RCSPs) and acquired knowledge from the petroleum industry and other private industries that have been actively drilling wells for more than 100 years. Specifically, this manual focuses on management activities related to the planning, permitting, design, drilling, implementation, and decommissioning of wells for geologic storage (GS) projects.

A key lesson and common theme reiterated throughout the seven DOE Best Practice Manuals (BPMs) is that each project site is unique. This means that each CCS project needs to be designed to address specific site characteristics, and should involve an integrated team of experts from multiple technical (e.g., scientific and engineering) and nontechnical (e.g., legal, economic, communications) disciplines. Additionally, works during the characterization, siting, and implementation phases of projects are iterative; the results from previously completed tasks are analyzed and used to make decisions going forward. This means that as data comes in, the conceptual model of the site is revised and updated to allow better future decisions.



1.0 Introduction

Carbon dioxide (CO₂) capture and storage (CCS) is one of several promising emission-reduction strategies that can be used to help stabilize and reduce CO₂ emissions in the atmosphere while maintaining America's energy independence. It is estimated in the 2010 Carbon Sequestration Atlas that the potential geologic storage (GS) resources within the United States and Canada are great enough to store more than 1,800 billion metric tons of CO₂, roughly enough capacity to store the annual amount of CO₂ currently emitted from stationary sources in the United States for at least 500 years.¹ The U.S. Department of Energy's (DOE) National Energy Technology Laboratory (NETL) has been actively researching and developing CCS technologies. The purpose of the DOE Carbon Storage Program is to demonstrate that CO₂ can be economically, successfully, and securely stored permanently in a manner that is compliant with the best engineering and geological practices; Federal, state, and local regulations; and in the best interests of local and regional stakeholders.

In a typical CCS project, CO₂ is captured at an anthropogenic source, transported to a suitable location, and injected into deep geologic formations for permanent storage in saline and hydrocarbon bearing formations. The GS portion of these projects is analogous to exploration and production activities of the petroleum and other injection industries. Much of our knowledge is based on the experience drawn from these industries. Wells are a critical component of any CCS project; they will be drilled and completed for multiple purposes, including: exploring the suitability of geologic formations; injecting CO₂; monitoring the behavior and location of injected CO₂; and, in the case of CO₂ utilization for GS through enhanced oil recovery (EOR) and enhanced coalbed methane (ECBM), producing fluids and gasses from the injection zone.

The purpose of this report is to share lessons learned regarding site-specific management activities for carbon storage well systems. This manual builds on the experiences of the Regional Carbon Sequestration Partnerships (RCSPs) and acquired knowledge from the petroleum industry and other private industries

that have been actively drilling wells for more than 100 years. Specifically, this manual focuses on the planning, permitting, design, drilling, implementation, and decommissioning of wells for GS projects. It is the seventh in a series of best practices manuals (BPMs) and builds on the frameworks developed collectively in the previous manuals. Integration of the material presented in the entire series of manuals², listed below, will provide the most benefit to the reader:

- Monitoring, Verification, and Accounting (MVA) of CO₂ Stored in Deep Geologic Formations (referred to herein as the MVA Manual)
- Public Outreach and Education for Carbon Storage Projects (referred to herein as the Outreach Manual)
- Site Screening, Site Selection, and Initial Characterization for Storage of CO₂ in Deep Geologic Formations (referred to herein as the SSIC Manual)
- Geologic Storage Formation Classifications (referred to herein as the Classification Manual)
- Risk Analysis and Simulation for Geologic Storage of CO₂ (referred to herein as the RAS Manual)
- Terrestrial Sequestration and Carbon Dioxide

A key lesson and common theme reiterated throughout the seven DOE BPMs is that each project site is unique. Practical CCS projects are designed to address specific site characteristics and involve an integrated team of experts from multiple technical (e.g., scientific and engineering) and nontechnical (e.g., legal, economic, communications) disciplines. As with the previous manuals, many technical and nontechnical aspects of CCS projects discussed in the BPMs are interdependent. CCS projects are implemented through an iterative process, so new information gained could impact decisions made in several different areas. For example, early site screening efforts inform decisions to drill test wells, and information from test wells inform site selection and injection and monitoring designs. Building on lessons learned from the petroleum industry and the RCSPs' efforts to date, this manual makes

¹ U.S. DOE/NETL, Carbon Sequestration Atlas of the United States and Canada, 2010, third edition.

² These Best Practices Manuals can be found online at NETL's Carbon Sequestration Program Reference Shelf website: http://www.netl.doe.gov/technologies/carbon_seq/refshelf/refshelf.html.

DOE's RCSP Initiative

The RCSP Initiative includes the participation of more than 400 government, industry, university, and research organizations. It was initiated in 2003 with the RCSPs' Characterization Phase, which was followed by the Validation Phase. Building on lessons learned from small-scale injection projects completed during the Validation Phase, the Initiative is now in the Development Phase. This final phase involves the planning and implementation of large-scale injection projects, which will lay the foundation for future demonstration and commercialization of CCS technologies. Lessons from the RCSP Initiative and the Carbon Storage's Program's Core R&D component have contributed to the development of practical experience with CCS technologies, human capital, active stakeholder networks, inputs to regulatory policy development, regional training, and the development of BPMs.

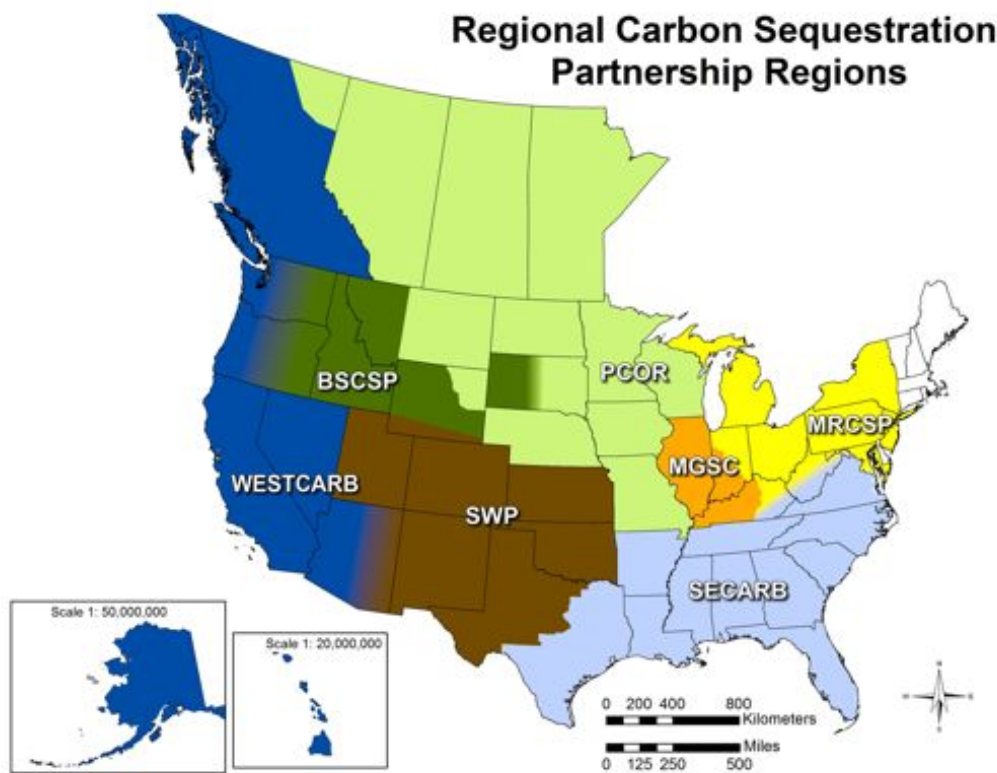

frequent reference to additional guidance and standards. The reader is encouraged to review these references for a more complete understanding of the best practices for wells in this manual.

This manual provides the reader with an overview of the management activities typically associated with CCS projects and is intended for those involved in the development and implementation of CCS projects, governmental agencies, and other non-governmental organizations (NGOs). This manual is not intended to provide the detailed information necessary to develop

CCS wells, but rather to assist those involved in CCS projects to develop an understanding of what to expect as a project unfolds, and the types of expertise that need to be included in the project team. **Figure 1-1** presents a brief overview of these activities by stage, starting with pre-injection planning and spanning the life of a project through post-injection operations. Each of these boxes represents a section in this document. To the side of each box is a brief indication of the activities involved at each stage; these are discussed in further detail in the remaining chapters of this manual.

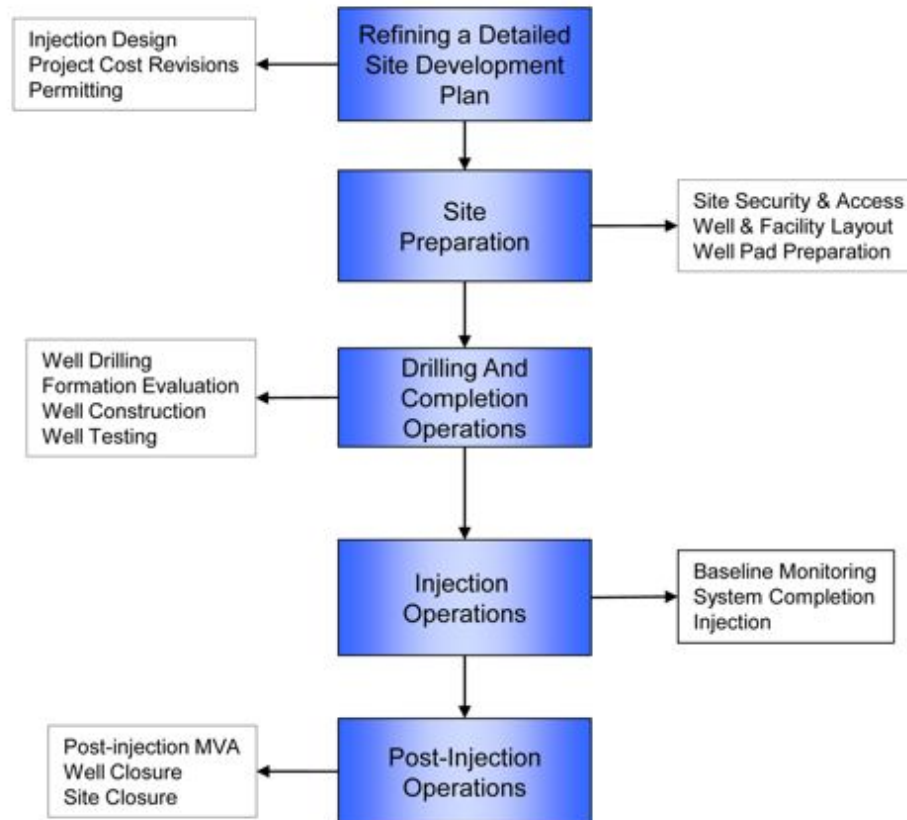

Figure 1-1: Overview of Major Well Management Activities by Stage of Project Development

- **Chapter 2**, Refining the Detailed Site Development Plan, outlines the major elements that need to be considered before site work begins, including injection design, project cost revisions, and permitting.
- **Chapter 3**, Site Preparation, outlines the elements of site preparation, including site access and security, facility and well locations, site grading, injection and well system preparation, and onsite pipelines.
- **Chapter 4**, Drilling and Completion Operations, includes a summary of typical drilling equipment, well installation and materials, well completion, and further well development.
- **Chapter 5**, Injection Operations, includes an overview of standard equipment, enhanced recovery, monitoring, and optimization.
- **Chapter 6**, Post-Injection Operations, describes activities that include long-term MVA, plugging and abandonment of both injection and monitoring wells, and site closure.
- **Chapter 7** is a conclusion.
- The **Appendices** include more detailed information on the following topics:
 - A. Compilation of Key Well Drilling and Construction Information for RCSP Test Sites
 - B. Sample Authorization for Expenditure (AFE) from the Petroleum Industry
 - C. U.S. Environmental Protection Agency's (EPA) Underground Injection Control (UIC) Program Contact Information by State
 - D. Oil and Gas Contact Information by State
 - E. References for Different Aspects of Well Drilling and Construction
 - F. Produced Water Disposal Options

This BPM builds on the decades of petroleum industry commercial practices with oil and gas exploration and production. As additional CCS-specific knowledge is gained through the Development Phase of the RCSP Initiative, the best practices described here will continue to be refined in later versions of the manual.

2.0 Refining a Detailed Site Development Plan

The planning associated with field work is a critical part of the storage project; the time and effort involved could be significant. Wells are interconnected with various aspects of a project, including: characterization, monitoring, regulatory compliance, and public acceptance (see the Outreach Manual). These various interconnections can affect the design, construction, and operation of wells. A Site Development Plan, as referenced in the SSIC Manual, describes the project layout and major project activities, including site assessment, projected costs, injection design, and regulatory compliance. As a Qualified Site is developed for storage, the Site Development Plan is typically refined with additional information gained during characterization. The process depicted in **Figure 2-1** highlights the aspects associated with refining a Site Development Plan to make it a Detailed Site Development Plan. Data collected to provide an assessment and initial site characterization can be used to address three key areas: (1) injection design, (2) project cost revision, and (3) permitting, which are critical components of field implementation. **Appendix A** provides an overview of the key well drilling and construction information for the test wells from the RCSP Program.

When assessing a site, the amount of existing data and the related uncertainties could vary widely from project to project. For example, in a mature oil field there would likely be significant site-specific data available and, as a result, fewer uncertainties about subsurface geologic properties. However, on the other end of the spectrum, some potential sites may have only a few existing wells within the basin, little site-specific data, and therefore greater uncertainties about the geologic properties of the site. During Site Screening and Site Selection, an operator can use existing information to develop an Initial Site Development Plan with preliminary estimates of the areal size needed to accommodate the project, required infrastructure (types and number of wells, compression, pipelines), and associated costs. While these preliminary estimates may be sufficient for maturing a project to a Qualified Site (see SSIC Manual), they may not be sufficient for doing the more detailed planning and budgeting required to develop a GS site. Therefore, before proceeding with site planning, an operator will typically evaluate the site characterization efforts to date, and determine if additional data and analyses are required. It should be understood that not all projects may need to conduct additional site characterization work at this stage, but the need for additional analyses should be assessed.

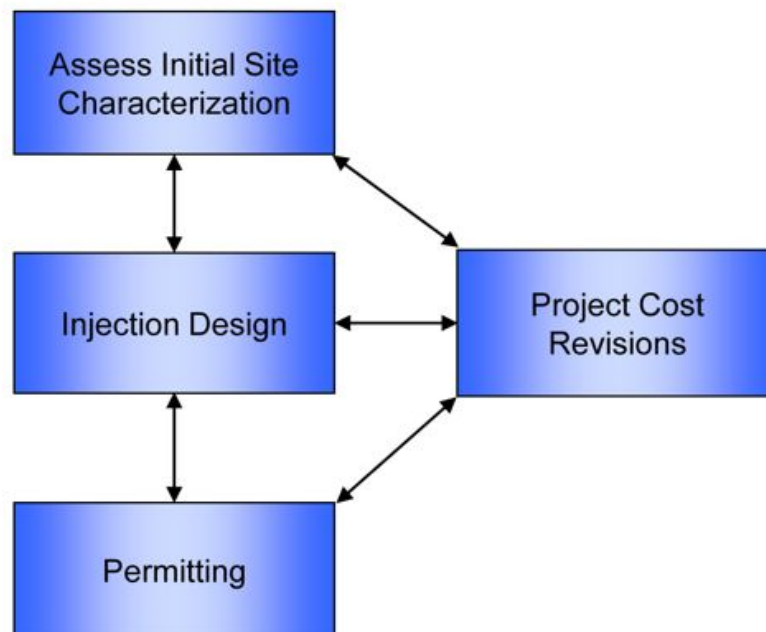

Figure 2-1: Key Aspects to Refine in the Detailed Site Development Plan

2.1 Assess Initial Site Characterization

A Qualified Site has likely completed the initial numerical models used to predict injection scenarios for plume migration (see the RAS Manual). These initial models are based primarily on readily available, but not necessarily free, data including:

- State Oil & Gas Commissions and Geologic Surveys data repositories of well log data, drilling records, cores, well tests, production, and geologic mapping.
- Existing site-specific information from previous drilling projects at or near the site (i.e., oil or gas wells, previous injection pilot projects, etc.).
- Private studies performed by the oil and gas industry; this may include existing seismic surveys.
- Published documents, such as the Phase I and Phase II geologic studies performed in conjunction with the RCSPs or available from various geological and engineering professional societies (American Association of Petroleum Geologists, etc.).

Models developed during the Site Screening and Site Selection stages could have a high degree of uncertainty depending on the amount and quality of the data. This level of data certainty might be sufficient for development of the initial Site Development Plan; however, it may not be sufficient for the detailed planning needed in advance of actual site work. Therefore, a formal data gap analysis could be conducted to identify data gaps or deficiencies and identify if there is a need for further characterization. At the same time, it may be useful to use a risk assessment and sensitivity analysis to gauge the importance of each component of missing information. As a result of these assessments, the operator may consider drilling exploratory or stratigraphic wells to address the identified data deficiencies. However, it may not be feasible to collect all the data necessary to completely address the identified data gaps. If the potential importance of this data is significant, it should be factored into the Risk Analysis and project budget contingencies.

The importance of certain data gaps will change throughout the project maturation process. For example, early in the project, the lack of whole core data might be compensated for by drawing rock properties from existing geophysical and electric logs and using those logs to fill in the missing geologic characteristics. In reference to one of their RCSP tests, the Midwest Geologic Sequestration

Consortium (MGSC) stated: “The ideal geologic model would be based on data that are both representative of the target zone and widely distributed throughout the study area. Given the scarcity of core data in the Owens facies, compared with the wide availability of electric logs, the use of log data as an estimator of rock properties was applied (Midwest Geological Sequestration Consortium, 2009).” Once the data gaps are gauged for their importance to the project at that stage, steps must be taken to perform any additional investigations to eliminate or reduce the gaps which are critical to the project’s success at that stage. Upon completion of the assessment, an iterative step could be performed to update the Risk Analysis and determine impacts on project budget. Once the assessment is complete, the project operator is now ready to move forward on the planning necessary to prepare for site work. This would include injection design, revising project costs, and addressing permitting.

Midwest Geologic Sequestration Consortium (MGSC)

Using Historical Information as a Baseline for the Site Characterization and Development of the Injection Design

MGSC relied heavily on the regional Phase I and Phase II assessment results for understanding the likely geologic characteristics they would encounter at their Illinois test site near Decatur.

Regional geology contained within these assessments provided critical information in planning/designing the well, including casing points and core intervals, given that no nearby wells existed.

The drilling program was based on the drilling experience from a nearby gas storage field, local seismic surveys, and regional structure maps based on wells penetrating the top of the Mt. Simon Formation. Because the nearest wells drilled to the base of the Mt. Simon were more than 35 miles from the site, inadequate geologic control was available to confidently select an extensive whole core program. Consequently, a more aggressive coring program was instituted in order to obtain sidewall rotary cores from a wireline conveyed tool for geologic samples/data. A much more involved whole core program was later implemented for the verification well so that MGSC could pick whole core intervals based on the injection well’s well logs.

Although there was not enough local information contained within the historical information and drilling studies, MGSC was able to refine the scope of their required characterization to fill specific data gaps.

2.2 Injection Design

An Injection Design addresses the overall plan for injecting the planned volume of CO₂ at an injection site. It is based on, and linked to, the reservoir or numerical simulation (see the RAS Manual) developed during SSIC efforts and continuously updated as new information is obtained and analyzed. It includes the design of both the layout of the injection field and design of the associated facilities. Specifically, the Injection Design should focus on well placement within the injection field and necessary layout for equipment related to operations, maintenance, and safety requirements. The placement of wells in the injection field should be based on modeling scenarios that incorporate inputs from the subsurface analysis to determine optimum locations for both monitoring and injection wells throughout the extent of the field.

2.2.1 Injection Field Layout

The injection field layout should consider all elements necessary for an injection field to operate, including, but not limited to: source and method of CO₂ transportation, compression facilities, and wells. The placement of wells in an injection field should be based on subsurface analyses and models used to optimize performance of the storage operation, including the storage capacity, injectivity, and security of the site.

These models take into consideration existing wells and appropriate spacing between injection and monitoring wells. Well placement could also be affected by issues other than subsurface conditions, such as site access and security, other site conditions (e.g., at the surface), and monitoring plans. Placements of injection wells could impact storage performance, installation scheduling, and project costs. Operational redundancy of injection wells can help provide for continuous flow of CO₂ by diverting flow to alternative injection wells when needed. Several considerations for the injection field layout are identified below:

- Reservoir Properties (Depth, Porosity, Permeability, Thickness, and Architecture)
- Existing Wells
- Proper Well Design and Spacing for Optimization of the Storage Reservoir (Capacity, Injectivity, and Containment)

- Casings Set Points and their Depths
- Site Access and Security
- Site Conditions
- Monitoring Plans

This manual will focus briefly on considerations for existing wells and proposed well spacing.

Existing Wells

There are often numerous advantages to utilizing mature well fields as potential carbon storage sites. As discussed in the SSIC Manual, knowledge available from existing wells reduces the cost and uncertainty of site characterization. In some cases, it may be possible to rework existing wells so that they can be used in the CCS projects. Existing wells may have recent logs available that can provide information related to the integrity of the well. Analysis of these wells can determine if they are in good condition or could be relatively easily reworked for use in a CCS project. Additional wireline logs may also confirm the suitability of the formation for CO₂ injection. Furthermore, the fact that wellbore stability has been maintained for an extended time provides added confidence in the well construction.

Internal and external mechanical integrity tests (MITs) are employed, and oftentimes mandatory per Federal Regulations, to identify problems related to wellbore integrity that could lead to movement of injected fluids out of the injection zone. If a problem is identified, various remediation activities can be undertaken to repair the identified problem (e.g., a cement squeeze job can be used to insert additional cement into voids between the casing and the formation to provide an adequate barrier to fluid movement). Koplos et.al., describes a variety of MITs and related wellbore failure rates, types, and consequences for a variety of UIC well classifications.³ The requirements for MITs for injection wells are included in the UIC regulations at CFR 40 146.8.

Well Design and Spacing

Well design and spacing considerations are made to optimize the performance of the injection and storage operations. In some instances there may be restrictions which impact the well design or spacing, or that require the project to avoid certain environmentally sensitive and/or populated areas. Horizontal wells, which could

³ Koplos, J.; et al. "UIC Program Mechanical Integrity Testing: Lessons for Carbon Capture and Storage?" 5th Annual CCS Conference.

lead to additional costs, may be necessary to limit disturbances at the surface while maintaining injectivity and access to formation capacity.

It is useful to run model scenarios to develop optimal well-spacing plans based on reservoir properties. Such modeling could evaluate the potential for plume migration interference by assessing the aerial extent of the CO₂ plume and the pressure front, and by predicting the fate and stability of injected CO₂ based on the planned project parameters and reservoir geologic properties. Several different industry-accepted numerical simulation models are available for injection modeling studies. Some of these have specific CO₂ plug-ins to aid in modeling and simulation of CO₂ injection. The model limitations and assumptions should be thoroughly reviewed prior to selecting the reservoir simulation tool to determine what is most suitable to a given project. Additional discussion of available models and applications to RCSP pilot field tests is found in the RAS Manual. Proper well spacing, using these simulation models, mitigates potential increase in formation pressure, which could also decrease the efficiency of the injection.

2.2.2 Facility Design

Facility design should be site-specific with different equipment, operations and maintenance (O&M) needs, and safety provisions. Factors that could impact facility design include CO₂ delivery method, the size of critical pieces of equipment, maintenance needs for that equipment, the number of onsite employees, expected site visits, and other factors.

The location of the CO₂ source will play a major role in the project planning. If the injection operation is within close proximity to the CO₂ source, pipeline costs and potential public acceptance concerns may be greatly reduced. MGSC indicated that a major consideration at their Illinois test facility was the possibility of capturing an existing, nearly pure stream of CO₂ and drilling an injection well within the same facility. When choosing the location of the injection facility, the location of the source or distance from an existing or planned CO₂ pipeline should be evaluated. This can be a major component of the total projects costs, due to cost of pipelines and potential compression that could be required for transmission of the CO₂.

2.3 Project Cost Revisions

The second key area to be addressed in the Site Development Plan is to update and revise the project costs that were estimated during the initial stages of project evaluation. An in-depth revision of project costs will iteratively consider the cost implications of significant design decisions for the implementation activities throughout the life of the project. Having a complete understanding of the potential costs will reduce the risk of underfunding the project, which may result in cost overruns or increased risk to project success. **Table 2-1** highlights well-related cost considerations for CCS projects that should be carefully assessed for various stages of a planned CCS project.

To accurately estimate project costs listed in **Table 2-1**, the operator will need to integrate various types of information in each stage of the project. A specialized contractor or consultant may be helpful in developing detailed cost estimates. For example, the Southeast Regional Carbon Sequestration Partnership (SECARB) used consultants for estimating their costs at their Black Warrior test site.

The AFE is a typical form that is used to develop an estimate for drilling costs that account for drill depth and casing points, completion and/or abandonment costs, drilling rig rates, fuel costs, drilling pipe and bits, casing cement, logging, coring, and testing, to name a few (See **Appendix B** for a sample AFE used in the petroleum industry). However, it is worth noting that currently, because the CCS industry is small, costs associated with drilling and testing wells are driven by the “supply and demand” associated with the petroleum industry and, hence, will be dynamic. An operator may want to plan for cost contingencies for the main project costs included in **Table 2-1**. Site- and project-specific costs will vary with the geology, permitting requirements, and geographic characteristics. They may also vary based on external factors such as ancillary demand for drilling equipment or supplies. MGSC, for example, experienced increased costs and a shortage of supplies and services due to a boom in the oil industry for the Illinois Basin area.

The U.S. EPA developed a “Geologic CO₂ Sequestration Technology Cost Analysis” to assess the current best estimates (in 2010) of the cost components associated with compliance with the UIC Class VI regulations.⁴ Additionally, DOE is currently developing tools to help estimate the cost of CO₂ storage as part of a CCS project.

⁴ U.S. EPA, “Geologic CO₂ Sequestration: Technology and Cost Analysis,” Office of Water (4606-M) EPA 816-R10-008, November 2010. Accessed online, 11/7/2011 at: <http://water.epa.gov/type/groundwater/uic/class6/upload/geologicco2sequestrationtechnologyandcostanalysisnov2010.pdf>.

Table 2-1: Major Cost Elements by Project Stage

Detailed Site Development Plan	Site Preparation	Well Drilling and Completion	Injection Operation	Post-Injection Operations
<ul style="list-style-type: none"> • Permitting and bonding • Well cost estimates (including exploration wells, if needed) • Acquisition of data for site characterization • Modeling • Obtaining detailed cost estimates for site-specific equipment modifications, rental equipment, construction (and related temporary) costs • Estimating scheduling impacts and developing contingencies 	<ul style="list-style-type: none"> • Site grading • Surface infrastructure (roads, pipelines, fences, security) • Well pad construction and preparation • Weather constraints • Water supply 	<ul style="list-style-type: none"> • Drilling rig costs (including scheduling) for site-specific conditions • Weather constraints • Injection and monitoring well drilling • Injection and monitoring well completions • Drill casing and tubing, cement, wellheads, downhole safety shutoff valve, packer(s), and all other associated equipment • Injection pumps and other associated equipment • Fluid and cuttings disposal 	<ul style="list-style-type: none"> • Well pad maintenance • Mechanical integrity and testing • Pressure falloff testing • Injection data monitoring and management • Evaluation of integrity of abandoned/plugged wells that penetrate the confining zone – mitigation if necessary • Equipment maintenance and replacement • Power • Labor • Well development • Weather constraints • Waste management • Monitoring well O&M • Injection well O&M 	<ul style="list-style-type: none"> • Monitoring equipment maintenance and replacement • Well plugging and reporting • Equipment and facilities removal • Site restoration • Closure activities

Some specific cost considerations worth noting include:

- **Permitting:** As part of the permit application, the operator may need to develop plans for well MITs, monitoring, well plugging and abandonment, and site closure.
- **Site Preparation:** The operator could tender contracts for a variety of site preparation costs, including equipment and construction of well pads, containment ponds, access roads, buildings, utilities, and other related infrastructure. Construction of a pipeline from the source area to the injection wells could be a significant portion of the total project costs.
- **Drilling:** The drilling costs are typically a major portion of the project costs and depend on the local geology, the well design, depth of the well, the type of drill rig used, and the location of the well. For example, deep wells which are far away from major roads and in remote locations will be more expensive than wells that are shallow and/or are in easily

accessible locations. Drilling characterization wells will consume a significant amount of resources, but they are critical to understanding the regional geology and provide details for future site activities. If feasible, it is recommended that operators retain as much flexibility as possible in determining the ultimate purpose for new wellbores (e.g., injection wells or monitoring wells). RCSP experience shows that it can be more economic to determine the suitability of a location before committing to the full suite of regulatory obligations necessary to complete a well for injection. Consideration should be given to utilizing existing depleted oil or gas wells for injection or monitoring; however, because most existing wells will not have long string casings that are cemented to the surface, it may not be possible to retrofit them for injection, and plugging and abandoning these wells may need to be considered instead. Also, if operators intend to transition a Class II well into a Class VI well, they should consider, in advance, the potential requirements for this conversion. Section § 144.19 of

the UIC Class VI regulations describe the factors that must be considered in this transition. They include the extent to which there is an increase in reservoir pressure or injection rates, a change in production rates, the distance from underground sources of drinking water (USDWs), the suitability of the area of review (AoR), abandoned wells, project plans, the characteristics of the CO₂ that will be injected, and any other site-specific factors that could have an impact.⁵

- **Completion:** Well completion costs may prove to be a large factor in the project budget due to the importance of the casing and cement in the injection well. Completion costs will be dependent on the purpose of the well, technical specifications, and requirements of the EPA UIC Program.⁶ In addition, any costs associated with well stimulation will need to be included.
- **Site Operations:** The main operations costs for wells at an injection site are from the costs of power and labor. The cost of power associated with the injection operation will be dependent upon the geographic location and the source of power, which could be a significant cost. The labor requirements of the injection operations will directly correlate with the monitoring plan and the level of automation associated with the injection facility.
- **Well Preparation and Waste Management:** After well completion activities are completed, the well or borehole should be “cleaned-up” to ensure proper injectivity. The technique for maintaining the injectivity of the injection zone throughout the borehole and at the injection point is referred to as well stimulation or well development. Various well development methods that can be implemented range from pumping the borehole to remove sediment and to reduce the turbidity of the water, to adding chemicals or acids to clean up the injection zone. The associated costs of materials, equipment, disposal of waste products, and labor will have to be considered. Additionally, other mechanical methods for preparing a well, such as using pressurized water or air, will require a source of water/air, equipment, and labor to implement the development. During the drilling process, the primary type of waste

generated will be the drilling fluids and cuttings; however, some municipal wastes will be generated (potentially including excess soil and biomass).

- **Monitoring and Maintenance:** These costs will be affected by the duration of the time required to keep the well(s) open, the costs of monitoring equipment, the integrity of equipment in the wells, and routine maintenance needs. The types and equipment for surface, near-surface, and subsurface monitoring of CO₂, as required by regulations, will have an impact on a storage project’s budget. The complexity of the monitoring equipment, climate of the area, expected replacement rate, and amount of routine monitoring that is required will directly affect the project monitoring and should be planned for accordingly. Some considerations include the potential for replacement of monitoring equipment, technological improvements, and best practices. Maintenance of the monitoring equipment will vary depending on the length of the monitoring program and could be impacted by the recent UIC Class VI and Mandatory Reporting of Greenhouse Gas Rules, which require extended periods of post-injection monitoring. Manufacturers of the monitoring equipment can be contacted to get an idea on the expected life expectancy of the equipment.
- **Post-Injection Operations:** Costs associated with post-injection operations include monitoring equipment and site maintenance, well plugging and reporting, equipment and facilities removal, and site restoration. The technical requirements for these activities are likely to be included in the permit for injection so the operator should consult the appropriate regulations to anticipate such requirements. Since EPA UIC Class VI guidelines require post-injection monitoring for a default period of 50 years, this cost can be significant.

⁵ See 40 CFR 144.19, found online at: <http://www.gpo.gov/fdsys/pkg/FR-2010-12-10/pdf/2010-29954.pdf>.

⁶ Please see the EPA UIC Program website for additional information: <http://water.epa.gov/type/groundwater/uic/index.cfm>.

2.4 Permitting

The third key area to be discussed in the Detailed Site Characterization Plan is activities and costs associated with the well permitting processes. A lesson learned from the RCSPs was that developing a thorough understanding of the various permitting processes and allowing adequate time and budget to complete the processes was critical to executing the project and maintaining a budget and schedule. Projects will require some combination of well and facility permits from Federal, state, and local agencies.⁷ Regarding permitting, the RCSPs also learned that including regulatory officials early in the planning process typically reduced the time required to ultimately obtain the permits. Furthermore, RCSPs also needed to obtain local (county and municipal) permits for certain characterization activities such as 3-D seismic acquisition. Although there are various types of permits to be obtained, this section will focus primarily on the injection well permitting process, followed by general discussion on other permits, and closing with information on some site-specific project plans that may be required to obtain permits.

2.4.1 Injection Well Permitting

Any well used for the purpose of injection of fluids into the subsurface requires a UIC permit. The permitting organization may either be a state agency or a regional office of the U.S. EPA, depending on the location of the well. **Figure 2-2** shows the territories where UIC permits are administered by either the state or EPA. The Federal UIC Program classifies wells into six different categories, including a recently approved Class VI category that specifically covers CO₂ injection wells. Previous injection wells for the RCSP small-scale injections have been permitted as either Class I (wells injecting non-hazardous industrial and municipal wastes under USDWs), Class II (wells related to oil and gas production), or Class V (experimental wells). Each well classification has different criteria and requirements that should be carefully reviewed and incorporated into the injection design as appropriate. The operator should contact the local permitting authority to help determine the correct permit for the application. The time required to complete and receive approval for the UIC permit can be considerable and may involve public

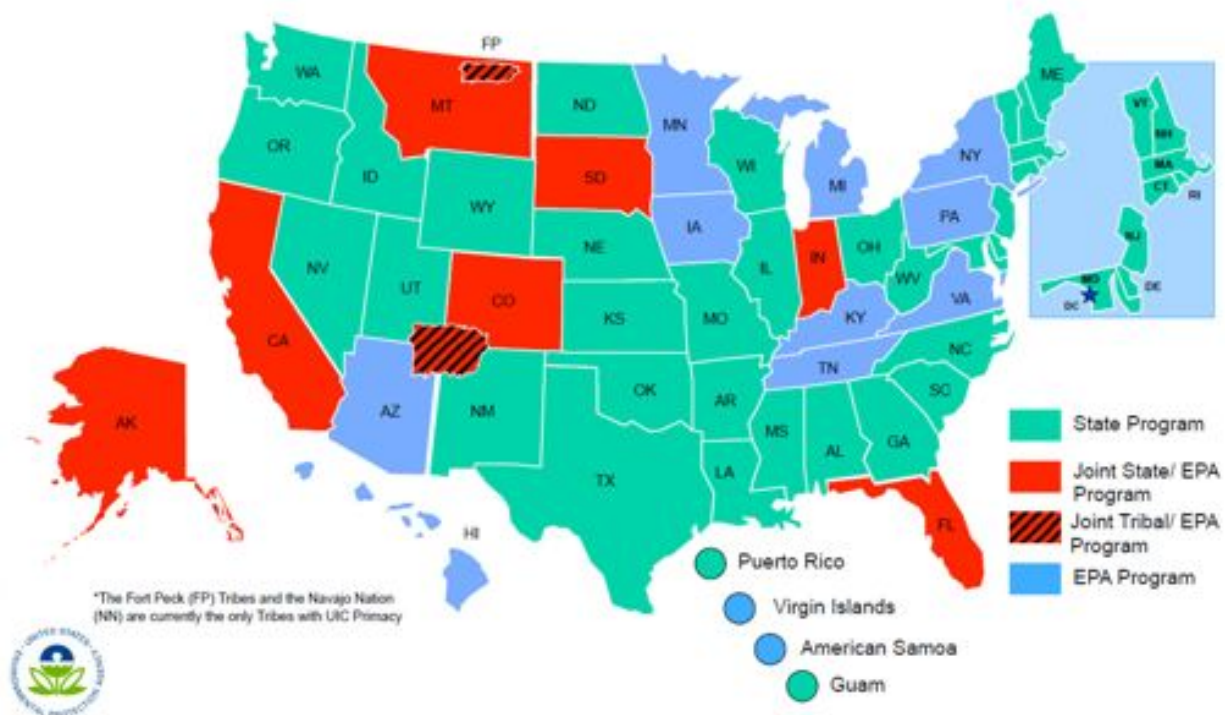

Figure 2-2: UIC Permitting Authority for UIC Class I-V ; as of 2011, no states have obtained primacy for Class VI and that status is not indicated on this map.⁸

⁷ CCS projects receiving Federal funding will also have to undergo a review under the National Environmental Policy Act (NEPA).

⁸ Depending on the nature of the project, an environmental survey and impact assessment may be required. A sample copy of the NEPA Questionnaire can be found at the following site: http://www.netl.doe.gov/business/forms/451_1-1-3.pdf.

hearings and review by the State Historic Preservation Office (SHPO) and Native American tribes, all of which can take several months and should be planned for within the project schedule (Advanced Resources International, Inc., 2010). For example, the permit approval timeframe for three SECARB projects ranged from 3 months for a Class II permit to 12 months for a Class V permit.

Table 2-2: Typical Injection Permit Information Provided by RCSPs

Information Typically Provided by RCSPs*
Geologic Information
<ul style="list-style-type: none"> • Injection Depth and Formation • Lithological Description • Lower-Most USDW • Testing of Multiple Sources of Groundwater • Model of Potential Plume Development
Well Design and Construction
<ul style="list-style-type: none"> • AoR Delineation and Justification • Legal Description of Land Ownership • Proof of Notification of Injection Intent to Affected Parties in the Region • Third Party Certifications for Injection and Construction • Construction details on all wells within the AoR and remediation action taken to improve these wells, if necessary
Description of Surface Equipment
<ul style="list-style-type: none"> • Proposed Equipment to be Installed • Equipment Sizing and Location Calculations • Proposed Average and Maximum Daily Rate of Fluids to be Injected • Proposed Average and Maximum Surface Injection Pressure • Potential Fracture Pressure Determination
Monitoring Systems
<ul style="list-style-type: none"> • Continuous Sampling of Multiple Neighboring Drinking Water Wells • Proposed Injection Monitoring Plan Equipment • Post-Injection Long-Term Monitoring Plan and Equipment
Logging and Testing Results
<ul style="list-style-type: none"> • Geophysical Data Supporting Location of Injection Zone and Caprocks and Absence of Resolvable Faults • Modeling of AoR Throughout Pre-Injection, Injection, and Long-Term Post-Injection

* Check with regulatory agencies for further requisites.

The UIC regulations outline the data that needs to be included in the application in order to obtain the permit. **Table 2-2** presents standard information that was presented by various RCSP projects for UIC permitting. Further project information may be required based on site location and project specifics. The newly approved EPA rule for UIC well Class VI is incorporated in the Federal rules governing all UIC wells in 40 CFR Parts 124, 144, 145, 146, and 147.

2.4.2 Additional Permits

Permits to drill characterization or monitoring wells may need to follow state oil and gas drilling regulations. The wells may be permitted as exploratory boreholes. A drilling permit application typically requires the following main items:

- Description of well type and target formation.
- Casing and tubing program.
- Blow out prevention plan.
- Surface owner and coal owner waiver.
- Construction and restoration plan.
- Deep well safety plan.
- Drilling site survey plat/mylar plat.
- Operator surety or blanket bond.
- Application fee for deep well.

During drilling, the periodic inspections by oil and gas regulators may be completed as necessary to certify items such as blow out prevention, casing runs, well completion, etc. Well completion activities may require additional well work permits.

The well and surface facilities construction may require a grading (earth-moving) permit and an approved rainwater runoff, erosion, and sediment control plan which are usually available through state, county, and local agencies. MGSC used standard methods such as silt fences and hay bales at their Illinois test site. Following the construction, the grounds were re-vegetated. For a proposed West Coast Regional Carbon Sequestration Partnership (WESTCARB) project in northern California, county-issued grading and drilling permits would not allow earth-moving or heavy equipment operations during the rainy winter months. These requirements also need to be accounted for when developing the project budget and schedule.

Permits related to potential discharges of produced water to groundwater may be required. Further, if it is expected that there will be a significant amount of produced water, the project could be considered a point source and be subject to the Federal National Pollutant Discharge Elimination System (NPDES) Program. It is important to fully understand what permits will be required for a project and allocate a realistic amount of time to obtain them.

In addition to the permits discussed above, the Plains CO₂ Reduction (PCOR) Partnership and SECARB had to obtain aquifer exemption permits from Federal regulatory authorities. General requirements may include: determination of the aquifer water quality before and after CO₂ injection, estimation of the distance of the exempted aquifer from public water supplies, and an analysis of future water supply needs within the area.

Some states may also require additional information after the injection permit is obtained, before final permission to inject is given. For example, SECARB reported that an additional MIT, to determine that the CO₂ could be safely injected, was required by EPA. MGSC indicated that it was necessary to submit a well completion report that described the data collected during drilling and the results of a step-rate test to determine fracture gradient.

A listing of Federal and state contacts related to CO₂ injection is a good starting point to confirm the types of permits which may be required for a particular project. A summary of these contacts are referenced in **Appendix C** and **Appendix D**. **Appendix E** provides a list of references for various stages of a project.

2.4.3 Supporting Project Plans

As part of the Class VI permit application, an operator may be required to submit site-specific project plans to address produced water use and disposal, closure, post-injection monitoring, mitigation, and remediation.

Produced Water

Fluids produced from oil and gas wells normally contain various concentrations of produced water. Water from deep geologic formations typically contains high concentrations of salts, in some cases orders of magnitude greater than seawater, and typically cannot be discharged

to the surface. When considering GS of CO₂ for the enhanced production of oil and gas, the production well activity may need to be a consideration for supporting project plans. Normally produced water in oil and gas operations is either piped or hauled offsite for reinjection to a permitted injection well. CCS EOR projects are likely to have existing infrastructure for produced water; however, geochemical effects of CO₂ injection should be considered as part of project planning. Further information concerning treatment, reuse, and disposal of produced water can be found in **Appendix F**.

Closure and Post-Injection Monitoring

An approved plugging and abandonment plan should be completed prior to issuance of the UIC permit (Riestenberg, et al., 2009). Chapter 5.0 in the MVA BPM introduces the monitoring objectives for closure and post-closure that will have to be considered as part of the project/MVA plan.

A typical MVA plan for CO₂ injection into a saline formation could potentially include atmospheric monitoring, shallow geophysical surveys, gas sampling, USDW monitoring, groundwater and geochemical modeling, testing, tracking, cased hole well logging, reservoir brine and groundwater monitoring, corrosion monitoring and MITs of the well materials, fall-off pressure testing, injection and observed pressure, and rate monitoring. According to the approved UIC Class VI requirements, the extent of the MVA plan should be approved by the Regional UIC Program Director.

Mitigation

A mitigation plan needs to identify, in terms of likelihood and severity, and address the potential risks and potential failures that may occur or have the possibility of occurring. A remedial work and safety plan should be prepared to allow for mitigating steps to be taken by the project team prior to any release. By having this detailed plan, in the event of an emergency, an effective and organized response can be implemented in a timely manner. All personnel that work and visit the site should have an understanding of the potential risks and understand the appropriate/available response actions. It is recommended that the plan should be shared with the local emergency response agencies so that they have a clear understanding of the project and are prepared to respond appropriately if needed.

3.0 Site Preparation

Site preparation activities for GS projects should be scaled to the stage and size of the project. As a project site is developed, the size of the affected area, or “footprint,” will likely change. In most of the RCSP Validation or small-scale projects, CO₂ was delivered by tanker truck rather than dedicated pipeline. The facility footprint remained similar in size during both drilling and injection operations to accommodate tanker trucks and limited onsite CO₂ storage. In contrast, a few of the small-scale injection projects that were coincident with oil and natural gas operations accessed dedicated CO₂ pipelines and had a smaller footprint during operations than during Site Preparation and Drilling. Large-scale injection projects can have multiple configurations (i.e., an injection facility might include a dedicated

CO₂ pipeline leading to one injection well), or it could include a dedicated pipeline, compression facilities, and multiple injection and monitoring wells spaced over several miles. However, the facility footprint in these large projects could be smaller than the well pad used for drilling and completion, depending on the configuration.

This chapter discusses some of the general site preparation activities necessary to prepare a site to become a CO₂ injection facility. As shown in **Figure 3-1**, these activities include: (1) site security and access, (2) well and facility layout, and (3) well pad preparation. Concluding this chapter is a section reviewing typical facility layouts based on experience from the RCSPs.

It is important to note that although this section presents the site preparation activities in a linear fashion, many of them may occur in parallel with each other.

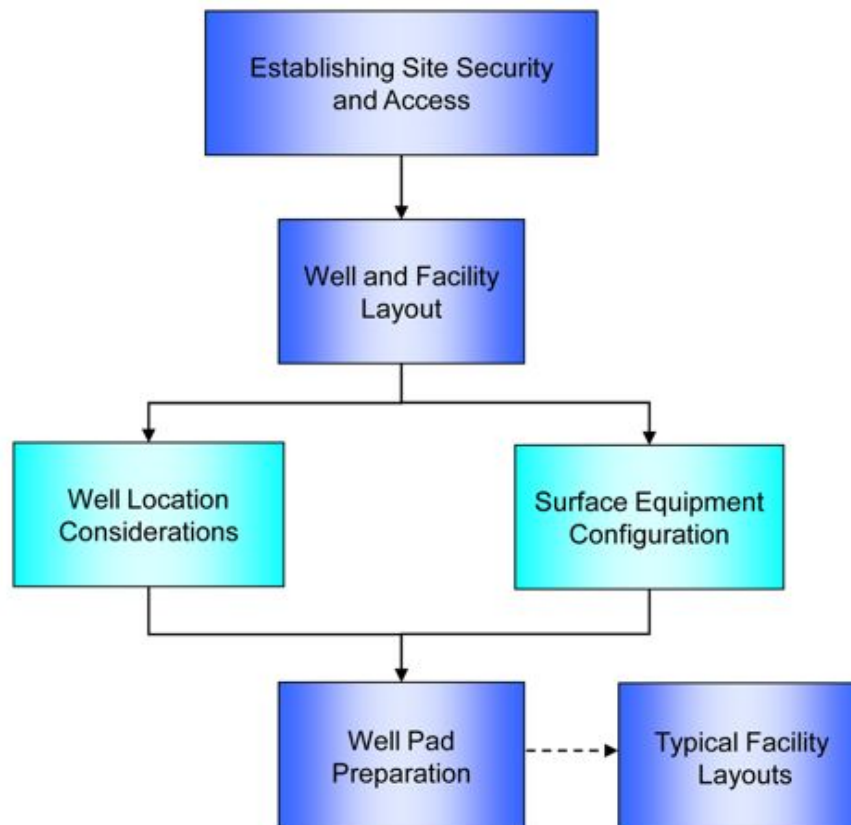

Figure 3-1: Generalized Flow Diagram Illustrating the Site Preparation Process

3.1 Establishing Site Security and Access

During active operations, a secure site will ensure the safety of the public as well as the workers. Although well drilling is a conventional industrial practice, it involves heavy equipment which must be operated by trained personnel. A secure site typically consists of surrounding the work area with fences, gates, and signs. Video surveillance cameras could be installed to monitor the critical areas of the site (CO₂ tanks, wellhead, injection equipment, etc.).

When planning a site, the operator should consider how equipment and materials will be transported to and within the site. If necessary, bollards could also be used for protection of equipment and pedestrians from vehicle traffic to and from the site. It is also advantageous to utilize existing public road infrastructure whenever feasible to limit disturbance to the environment. Road usage is typically required during almost every phase of the injection project for transporting equipment and materials to the site. The degree of usage will likely vary and typically be heaviest during the construction/drilling phase. In addition, during small-scale injections additional usage could be required for truck delivery of CO₂. Operators should work with permitting agencies and local municipalities to determine if roads being used will have additional requirements such as highway occupancy permits, road bonding, or weight and usage restrictions.

Planning Around Road Use Restrictions

Though it is advantageous to utilize existing road infrastructure, it may not always be feasible to do so. In the case of the MGSC EOR pilot project located at the Owens #1 site in Illinois, the CO₂ for injection was delivered by truck. Bulk delivery by truck is often the only feasible option for small-scale test projects. The nearest roads, however, were not rated to handle the weight of the delivery truck on the access road leading to the Owens #1 site located approximately a quarter-mile (400 meters) from the paved township road. Therefore, the injection equipment was located adjacent to the township road and a 1,280-foot (391-meter) pipeline was constructed to transport the CO₂ to the well (Midwest Geological Sequestration Consortium, 2009).

Within the site boundary, the road requirements will likely change throughout the life of a project. During the installation and construction activities, the roads can typically be gravel roads which can handle the loads of heavy equipment, such as drilling rigs, well completion, and site construction equipment. When the project moves into the injection operation stage, the need for such routine heavy vehicular access could change. For small-scale pilot tests involving truck transport of CO₂, the volume of truck traffic will increase during the injection operations. In this case, there could be an increase in vehicular traffic; therefore, delivery entrance and exit points should be in separate locations to avoid truck turnaround and provide for efficient access and egress. For large-scale projects, delivery of CO₂ would most likely be via pipeline; therefore, there will only be an occasional need for heavy equipment such as workover rigs, logging trucks, or Vibroseis (seismic acquisition) trucks to access the site.

In some instances, existing roads are not available and a new road has to be constructed. A new road should be designed in accordance with Federal, state, and local regulations and industry standards. When siting and constructing a new road, consideration of environmental impact is important. Factors of concern include erosion; excessive disturbance; fugitive dust and air pollution; and impacts to wetlands, natural waters, and the proximity to sensitive pieces of equipment. The design, layout, construction, and maintenance practices should be tailored to minimize these potential impacts.

3.2 Well and Facility Layout

The overall footprint of injection facilities will depend on the specific operational requirements of the project. Like many oil and gas operations, CO₂ injection well facilities should be constructed to minimize aesthetic (in the case of a higher visibility location) or spatial (in the case of a farmland location) impacts. The individual layout of these facilities should be designed in a manner that promotes safe, efficient work practices and provides for adequate movement and transportation around the work areas. In some cases, the injection facility may be located near existing oil and gas or other industrial operations, such as power generation facilities. In these cases, it can be advantageous to share some of the existing infrastructure.

Three types of surveys and assessments that may be conducted when developing the site include a topographic survey, geotechnical survey, and an environmental

resource assessment. In addition, there may be separate information requirements for the drilling of a well that are imposed by the state. This information varies by state, but typically includes a location survey, drilling surveys, well completions, a drilling program (e.g., cement and mud), and other plans and information. These could be independent requirements separate from the information requirements for surface facilities described below.

3.2.1 Topographic Survey

A topographic survey is performed to gather data on manmade and natural features of the land surrounding a potential site, in turn producing a topographic map. The survey should be large enough to include the extent of grading, sediment controls, and any road work that will likely be required. This data is then analyzed to select a location that provides for a reasonable cut and fill balance—thus reducing the need for offsite borrow or disposal activities. It is recommended that when possible, the well pads should be located in areas that require the least amount of fill or excavation while providing a suitable injection point entrance to the target storage formation. In addition, drainage issues and wetland impacts must be considered, especially in low lying areas. Topographic mapping can also be used in the preliminary design of the well pad area since the pad construction typically requires terrain alteration.

3.2.2 Geotechnical Survey

Prior to initiating the design and placement of the injection facilities and access roads, a full geotechnical characterization study could be completed. A geotechnical survey acquires information about the physical characteristics of soil and rocks and is typically required for siting heavy equipment such as compressor stations. This survey includes identifying different soil types and conducting standard penetration tests (SPTs) and blow counts at locations usually on a predetermined grid. Blow counts are a common geotechnical testing method used to evaluate the shear strength of soils as part of a foundation design. This information can be used to assess site stability and help determine the design measures that will be required. The weights and operating requirements for all components of the injection facility should be examined and included as part of the geotechnical assessment. For example, reciprocating compressors may require substantial excavation and concrete for foundations and potentially require piling. Excavation equipment, equipment weights, footers, and

piling requirements will have an effect on geotechnical stability that must not be overlooked.

3.2.3 Environmental Assessment

Environmental assessments are typically performed to locate wetlands, water features, endangered species, and other environmental features of concern. To the extent practicable, any water resources or wetlands features should be avoided when selecting well and access road locations. An environmental assessment usually identifies the environmental features of concern in relation to the proposed well location, the well pad layout, the access road, and the well pad area. The topographic survey (described above) can be used to develop the site grading plan and erosion and sedimentation control plan. To the extent practicable, the well pad and access road should be located to minimize environmental impacts (e.g., to streams, wetlands, etc.). The local officials may require formal environmental assessments if the site receives Federal funds (the National Environmental Policy Act [NEPA]), is located on Federal or tribal land (NEPA), or if the state has additional requirements (e.g., the California Environmental Quality Act [CEQA] in California). The project should check with local officials to determine any additional requirements.

3.2.4 Well Location Considerations

The location of the injection well(s) should be based on subsurface geology; however, physical surface well locations may be influenced by a number of factors, including site topography, access, geotechnical, and environmental constraints, as well as the presence of existing wells and their potential for use (as in EOR projects), and existing surface infrastructure.

For large-scale carbon storage projects, multiple injection wells will likely be required. The information gathered during site characterization can be integrated into models to customize the drilling design of the injection well(s) and to determine the well spacing and configuration within a field to optimize injection. It may be possible to place injection wells within relative close proximity to one another, particularly if directional drilling is used or CO₂ is injected into multiple stacked storage formations. The popularity of well designs consisting of multiple horizontal lateral wells, stemming from one main injection well pad, is a common petroleum industry practice. This method allows for multiple injection points into a large reservoir from one surface source. The design takes advantage of much-improved directional

drilling methods to create a larger injection profile while benefiting from lower costs due to reduced field equipment and materials. Although multiple lateral wells were developed more than 50 years ago, interest in this design for the purpose of CO₂ injection and natural gas recovery has recently increased. Multilateral wells can be used in cases with limited surface access while still taking advantage of subsurface carbon storage potential. These cases require significant modeling to maintain adequate reservoir conditions and minimal impact to adjacent formations.

Several aspects must be taken into consideration when designing multiple well placements. MGSC stated that some of the advantages of placing the injection wells within close proximity to each other include access, data acquisition, and easier collection of monitoring data. During the drilling and installation, real-time design decisions can be made based on the information obtained during earlier well(s) construction. This information can be used to update the conceptual site models and optimize drilling at other locations.

3.2.5 Planning Surface Equipment Configuration

The required facility size should be dependent upon the characteristics of the injection process such as the amount of CO₂ to be stored, planned injection rate, depth, and pressure. These characteristics shall dictate the size and selection of the injection equipment, piping, compressors, and CO₂ storage tank(s) if needed. Once selection of the equipment is completed, the operator typically configures the site to industry standards with an emphasis on safety. Valve controls should be placed to allow for safe and practical startup, O&M, and shutdown. Pressure relief valves are generally located to prevent personnel injury and equipment damage. Additionally, the facility's piping system should be designed to eliminate the potential for trapped CO₂ liquid to change phase and contribute to fatigue in the line.

Climate conditions at the injection site should be carefully considered during the design of the injection facilities and scheduling of field activities. Extreme temperatures and weather can cause problems with some of the equipment and facility operations. Support buildings might need to be constructed to protect equipment and electronics from the elements.

The principal utility for the surface equipment onsite during injection is typically electrical service. The type of electric service required could depend on the demands of compressors, other injection equipment, and onsite facilities. For a short-term pilot test project, portable diesel-powered generators could most likely provide the most economical supply of power. Backup diesel generators may also be required to allow for potential generator mechanical failures and maintenance. Generators may also be used as backup power supplies for large-scale injection operations.

For large-scale projects, a dedicated power line/drop might be required to meet the energy requirements. Depending on the location of the injection site and availability of the power supply, natural gas-operated compressors may be a viable and economic option. Depending on the injection facility and staffing requirements, water, sewer, and natural gas service may also be needed for support personnel. For any buried service line, the location should be planned to avoid any potential future excavation. The location of the underground utilities should be indicated at the ground surface and included on all as-built drawings. If an overhead line is used, the path should not hinder the passage of large vehicles and drill rigs, nor should they be located over any wellhead.

Some CO₂ injection pilot tests and facilities have made use of inline CO₂ heaters. These heaters are typically powered by propane, which can be stored in onsite tanks. The size of these tanks should be sized based on the demand of the heater. If propane tanks are used, the placement of the tanks would be dictated, in part, by the local fire ordinances.

When the planning and design for the surface layout has been completed, construction of the injection facility can be initiated. During this time a set of "redline" plans should be located onsite. These plans are typically updated weekly to make note of any changes to the original design. The term "redline" is used in the construction industry for a set of plans that are written on, typically in red, to indicate changes that were made in the field. Upon completion of the facility construction, changes to the original plans are typically verified by the site engineer, and properly surveyed, and an updated set of as-built design drawings should be generated for the operator in conjunction with the original redline plans.

3.3 Well Pad Preparation

The prospective well location will require a surface pad be prepared to accommodate the drilling operations (including the drill rig, logging equipment [if needed], trucking, completions operations, etc.). The size and orientation of the pad will vary from project to project and typically depend on the type of rig that is used, plans for source water and produced water management, the proposed layout of the site, topographical and geotechnical constraints, environmental constraints, and future maintenance and access needs. MGSC constructed a drilling pad that was 200 feet by 150 feet at the Decatur Site because it was to hold both an injection well and a well with a permanent geophone array; however, the SECARB Black Warrior Site was able to use a pad that was 100 feet by 100 feet. The ideal well pad would not take up any extra space than is required by the operations and would require little excavation or fill to construct. Following these guides should help to protect the environment while keeping construction costs to a minimum (Lyons & Plisga, 2005).

Typical well pads are designed with particular attention given to the ability of the pad to fully support the drilling rig and well casing pipe, but also for drainage and fluid collection during drilling operations. In many cases, precipitation or fluids generated on the pad are treated as waste products and should be collected and stored in onsite ponds or tanks. A good practice would be to divert all off-pad precipitation and runoff away from the pad to prevent the generation of any unnecessary waste.

Prior to well pad construction, the operator would have already performed all the surveying, testing, and permitting necessary to initiate well pad construction. Typically, the first step of constructing the well pad is to clear any unnecessary vegetation. Next, the top soil should be stripped and stockpiled for later use in reclamation after the operations are complete. The area is then leveled, sometimes requiring excess excavation or fill; however, as previously discussed, proper balancing of the cut-fill is usually preferred. The geotechnical requirements of the anticipated drilling operations and injection facilities will dictate the specifics of the required excavation/fill plan.

Once the pad area is leveled, it should be graded to divert water to drainage ditches and/or dedicated holding ponds. Typically, other dedicated ponds, pits, or lagoons are used to store water for drilling mud and other operational requirements and for drill cuttings. The design of the well pad and associated pits and ponds should be consistent with pertinent state and Federal regulations and drilling permit requirements.

3.4 Typical Facility Layouts

As previously mentioned, the facility layouts may differ depending on the stage of the project. Once site preparation is completed, a drilling plan will most likely be implemented. At this point, the site could consist of a drilling rig, mud pit(s), pipe rack, onsite office or job trailer, parking area, and portable toilet facilities (unless long-term permanent facilities are necessary). For each site, space requirements for well construction, rig footprint, drilling fluid system, and workover activities, such as removing and replacing tubing or packers, will need to be considered. For smaller facilities, a continuous gravel pad may prove to be a viable option for reducing mud during wet weather and keeping the work area relatively free of excess vegetation. MGSC opted to place a gravel pad around the Owens #1 portable separator, office trailer, and parking area. The CO₂ tanker delivery area was also lined with gravel (Midwest Geological Sequestration Consortium, 2009). **Figure 3-2** is an example of a drilling layout from an RCSP pilot test project.



Figure 3-2: Example of a Facility Layout During Drilling

During injection operations, the site will include injection well(s), injection equipment, and the monitoring equipment. Depending upon the site-specific conditions, the injection equipment may be placed in a separate location away from the injection well(s). The surface

footprint of injection and monitoring wells as shown in **Figure 3-3** and **Figure 3-4** is much smaller than the drilling footprint from **Figure 3-2**. The monitoring well shown (yellow) in **Figure 3-4** is a typical groundwater monitoring well.



Figure 3-3: Example of an Injection Well



Figure 3-4: Example of a Groundwater Monitoring Well

(Note: The monitoring well is yellow and in the foreground; the tanks in the background are used for fluid and commercial product storage and are unrelated to the monitoring program.)

3.4.1 Examples of Small-Scale Injection Layout

Injection equipment used by MGSC, shown in **Figure 3-5**, included a 60-ton storage tank, a propane-fired in-line heater (used to warm the CO₂ to avoid thermal shock to the tubulars and reservoir), and an injection pump skid (with specifications of up to 1,200 pounds per square inch [psi] surface pressure and 5.4 tons per hour pumping rate) (Midwest Geological Sequestration Consortium, 2009).

This equipment was configured for operation as shown in **Figure 3-6** and **Figure 3-7**. Carbon dioxide from the storage tank was pumped to the skid and further compressed, heated, and piped into the injection well. The monitoring equipment adjacent to the injection well was used to keep an eye on the injection process. Several CO₂ sensors and groundwater monitoring wells were located nearby to track the CO₂ plume and detect potential leaks. Another schematic of the injection equipment and site layout for an RCSP small-scale injection is depicted in **Figure 3-8**. Notice that the entire injection equipment is contained on top of a large trailer for easy transportation and operation.

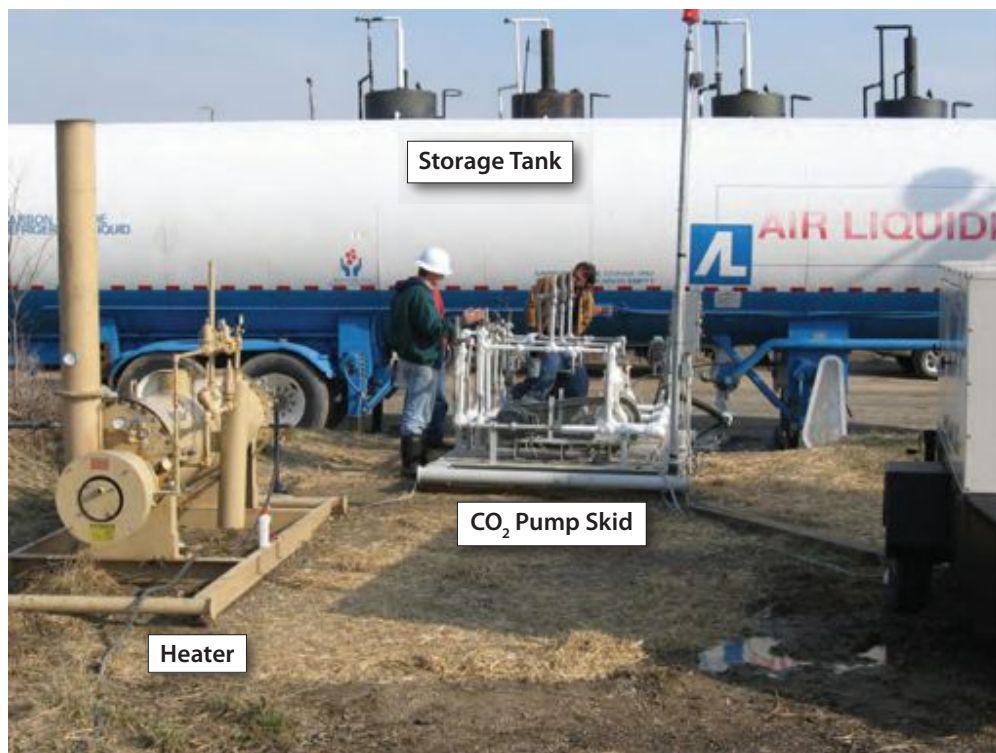

Figure 3-5: Example of Injection Equipment
(Midwest Geological Sequestration Consortium, 2009)

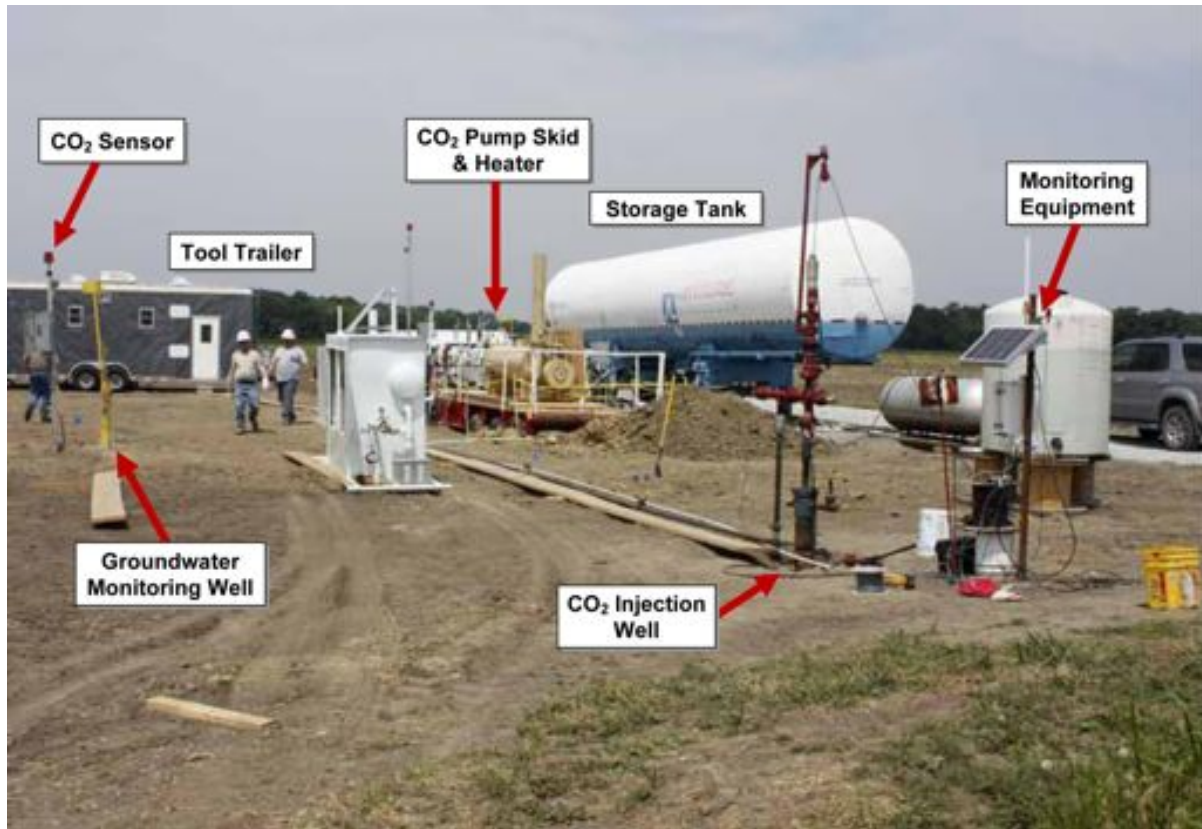

Figure 3 6: Side View of Injection Equipment Layout at MGSC Tanquary CO₂ Injection Pilot Project

(Illinois Basin: Tanquary CO₂ [Coal] Injection Pilot, Scott M. Frailey, ISGS. Presented at "Coal-Seq VII," March 8, 2011, Houston, Texas)

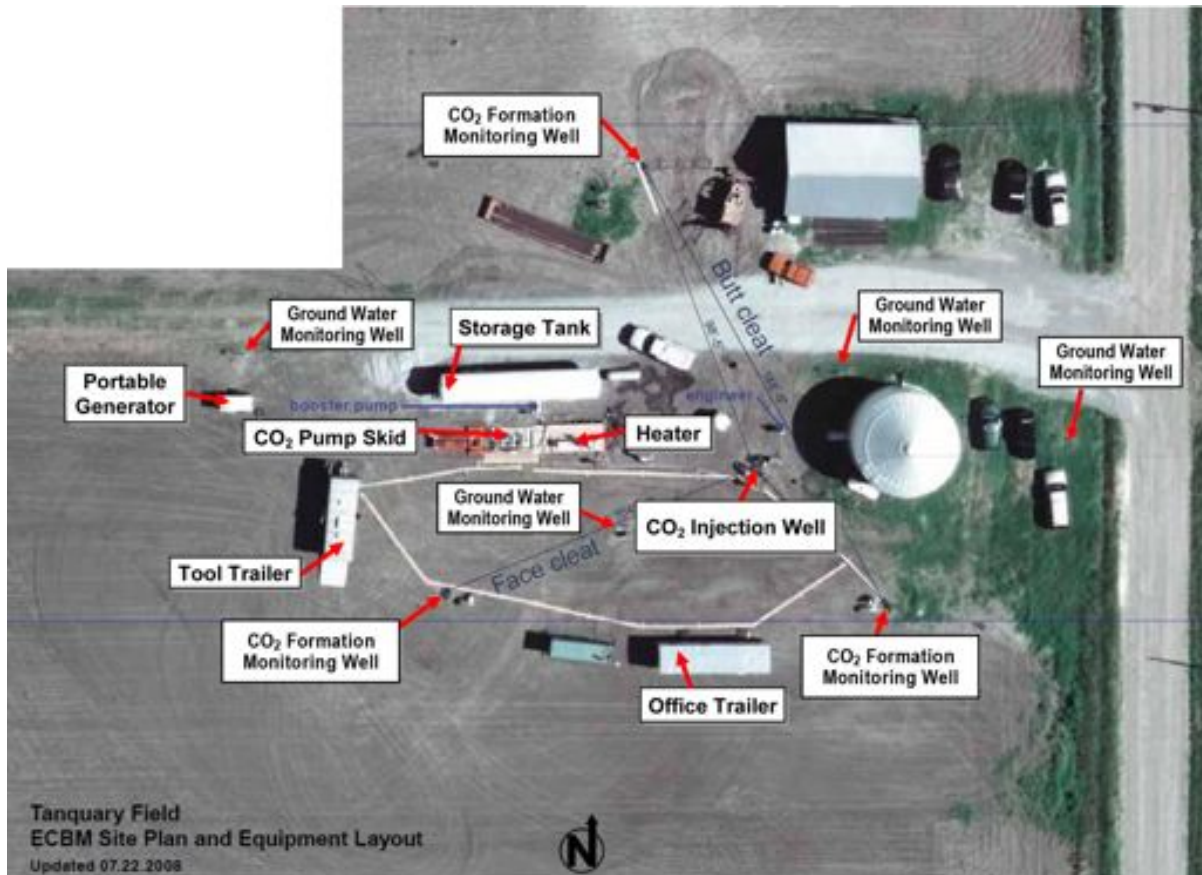

Figure 3-7: Aerial View of Injection Equipment Layout at MGSC Tanquary CO₂ Injection Pilot Project

(Illinois Basin: Tanquary CO₂ [Coal] Injection Pilot, Scott M. Frailley, ISGS. Presented at "Coal-Seq VII," March 8, 2011, Houston, Texas)

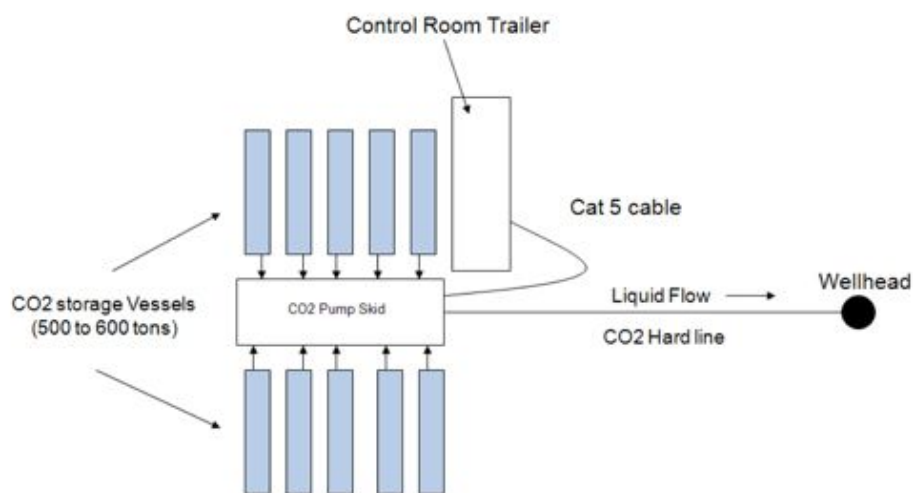

Figure 3 8: Injection Equipment Arrangement for East Bend CO₂ Test

(FINAL REPORT: "CO₂ Injection Test in the Cambrian-Age Mt. Simon Formation, Duke Energy East Bend Generating Station, Boone County, Kentucky." By: Battelle, for MRCSP, NETL)

4.0 Drilling and Completion Operations

The activities discussed throughout this chapter focus on the implementation of drilling and completion operations for wells.⁹ These activities are typically planned early and documented in a drilling and completion plan. Moving forward with drilling operations, it is assumed that the operator has obtained approval from the appropriate regulatory agencies for specific plans and schedules for each operation, including drilling, logging, and well completion. As previously mentioned, each project injection site will be unique and have specific drilling

and completion procedures based on site-specific conditions. The information presented in this chapter is not all inclusive, but tries to introduce to the reader general discussion on topics affecting activities such as: (1) well drilling, (2) logging and formation evaluation, (3) well construction, (4) well completion, and (5) well evaluation, as well as some key information gained from the RCSPs. It has been stressed throughout this manual that the steps involved in developing and implementing CCS projects are usually iterative, and this is particularly the case in well drilling and completion, as indicated in **Figure 4-1**. **Appendix A** provides an overview of some of the design specs for wells in the RCSP Program.

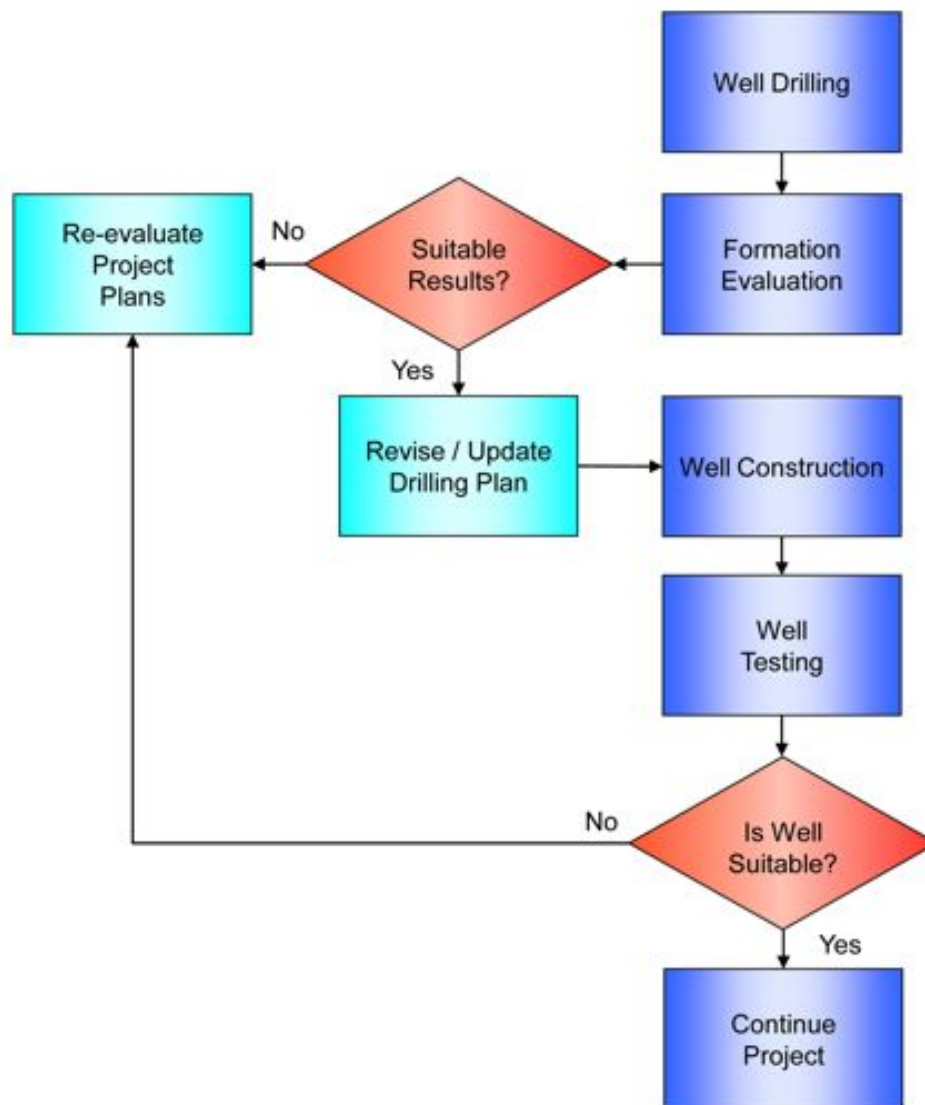

Figure 4-1: Key Steps and Decisions in Drilling and Well Completion Process

⁹ Note: This manual refers primarily to onshore wells, not offshore wells, unless specifically indicated.

Figure 4-1 presents generalized flow diagram of the key steps and decisions involved in drilling and completing injection and monitoring wells for carbon storage. Well drilling activities begin with a determination of the equipment, drilling method, and material to be used for each well based on site-specific characteristics gathered from previous investigations if available. Once these determinations have been made, the drilling rig and support equipment can be set-up and the borehole(s) can be drilled. During the drilling process, information regarding the subsurface is acquired through use of mudlogging, coring, and logging tools. After drilling is finished, a complete formation evaluation is conducted to characterize the stratigraphy and lithology of the injection and confining zones. The evaluation could include, but not be limited to, a more advanced suite of logging tools, additional sidewall cores, drill stem, and reservoir fluid tests. Once all the subsurface information has been collected and analyzed, the operator will need to determine if the injection and confining zone rock properties are suitable for carbon storage. If the results of the evaluation, of the borehole data, are not suitable, then the drilling and completion plan will have to be re-evaluated. If the results are suitable, adjustments still may be required and, as appropriate, the well completion program can be revised.

The process then continues with well construction, including the placement of casing, cement, and wellhead equipment. The completion of the well will overlap with the drilling process, particularly in wells with multiple strings of casing. Once the well has been completed, it can be developed to produce fluids for analysis and, if necessary, stimulation can be applied as permitted. A key step in well design and construction is the selection of perforation zones. The location of these zones could have a significant impact on the effectiveness of the injection and efficient use of the reservoir. It is likely that the permits will require that the well be tested for leakage, MIT, and cement bond log (CBL) to ensure that it has been properly completed and to evaluate the properties of the target zone for the injection of CO₂. If the results of the testing are not suitable, more well development and/or stimulation may be required.

If a deep monitoring well will be located near the intended injection well, there may be justification for drilling and installing the monitoring well first. The information obtained during its drilling can be used to modify the location and design of injection well(s), which are more costly to drill and install. The required time for the drilling

and completion operations will depend on the depth of the target formations, the geology of the subsurface, the number of injection and monitoring wells, and the type(s) of wells constructed. The remainder of this chapter elaborates on these activities.

4.1 Well Drilling

Once the site pad is completed, the well drilling activities begin with the mobilization and installation of a drilling rig and support equipment at the site. There are a variety of drilling methods that can be utilized to address site-specific conditions. Different drilling stages may require separate drilling methods, personnel, and equipment depending on the pre-injection plans and schedule. Part of the drilling process involves material handling of waste and drill cuttings as a means of minimizing the environmental impact.

Some states require drillers to be licensed as a company and/or as individuals, and some states require individuals with certifications to man the rigs. It is important to review the state licensing laws for drilling operations. In order to assure safe operations, optimize data collection, and minimize the risk of cost overruns, it is advantageous to work with experienced drillers and associated service companies. The RCSP experience showed that the involvement of qualified professionals with specific expertise in drilling and familiarity with the region and the local subsurface geology was an important factor to smooth drilling operations. Local experts and companies having knowledge of the region was useful in optimizing drilling, determining depths of target formations, and avoiding/anticipating and preparing for potential drilling hazards. A list of reference material concerning several aspects of the drilling and completion process has been provided in **Appendix E** to further assist operators in selecting drilling support.

4.1.1 Equipment

The equipment used during drilling operations includes not only the drilling rig and equipment, but also a variety of supporting equipment. **Figure 4-2** provides a general diagram of an onshore drilling rig, highlighting equipment and components that are part of the drilling process. The drilling rig and equipment must be suited to optimize drilling, completion, and operation of the well. The type of drilling rig should be selected based on site-specific factors, such as the layout of the drilling pad, drilling method to be used, depth of well to be

drilled, type of rock to be encountered, and well casing requirements. The time required to set-up a drilling rig will vary depending on the type of rig.

There are various types of rigs that can be used to drill injection and monitoring wells. Large drilling rigs generally come in three types based on height: a “single,” “double,” or a “triple” derrick. These designations refer to the number of drill-pipe joints that a rig can pull intact from the hole before a break (disassembly of the drill-pipe joints from one another) is necessary. For example, a single would require that each joint be broken from the drill string as it is removed from the hole. Likewise, a triple would be able to remove three drill pipe joints prior to breaking from the drill string. Deep boreholes can be drilled faster using a rig that allows you to pull out multiple drill-pipe joints from the hole without breaking each one. Less breaks result in less required labor and time

during “tripping” in and out drill pipe, which ultimately results in lower operating costs. Although operation costs may be less for a triple, the mobilization, daily rate, and set-up cost for the larger drill rig is typically much higher than for a rig with a single-height derrick.

Each joint of drill pipe can vary in length from 10 to 30 feet; however, deeper well drilling typically uses 30-foot joints. The drill pipes are constructed of steel or hardened aluminum and are hollow to allow circulation of cuttings and drilling fluids. The ends of drill pipes are equipped with female and male threaded fittings (box and pin) so that additional joints can be added during advancement of the borehole. The threads are tapered to allow the joints to be broken. The majority of the drill string is made up of the drill pipe, which is typically held in tension to minimize the tendency to buckle under its own weight. For deep holes, backpressure may also be applied to relieve some of the weight on the bits.

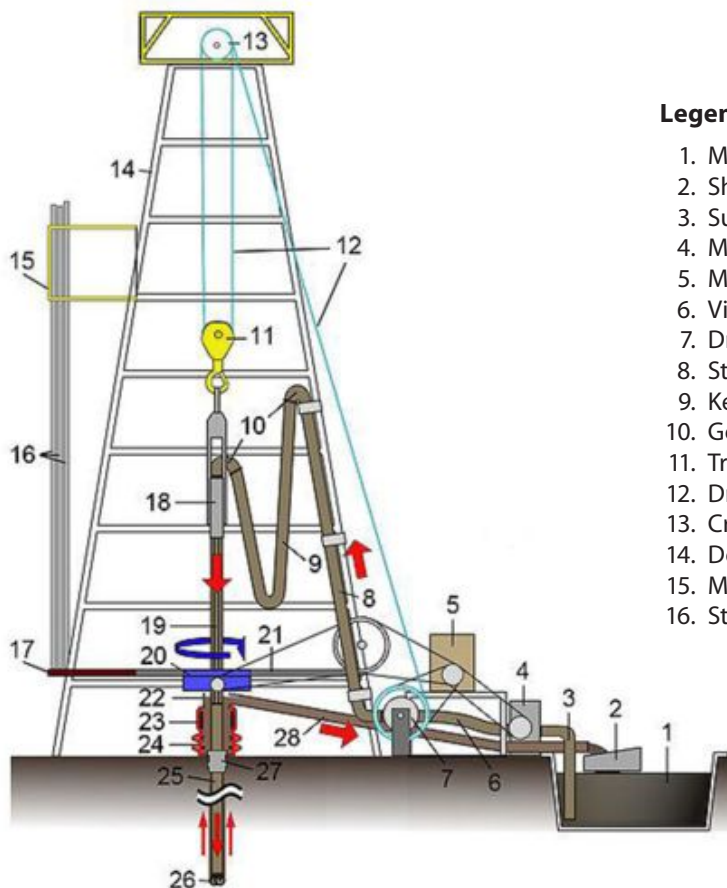

Legend

- | | |
|----------------------------|--|
| 1. Mud tank | 17. Pipe rack (floor) |
| 2. Shale shakers | 18. Swivel (on newer rigs this may be replaced by a top drive) |
| 3. Suction line (mud pump) | 19. Kelly drive |
| 4. Mud pump | 20. Rotary table |
| 5. Motor or power source | 21. Drill floor |
| 6. Vibrating hose | 22. Bell nipple |
| 7. Draw-works | 23. Blowout preventer (BOP) Annular |
| 8. Standpipe | 24. Blowout preventers (BOPs) pipe ram & shear ram |
| 9. Kelly hose | 25. Drill string |
| 10. Goose-neck | 26. Drill bit |
| 11. Traveling block | 27. Casing head |
| 12. Drill line | 28. Flow line |
| 13. Crown block | |
| 14. Derrick | |
| 15. Monkey board | |
| 16. Stand (of drill pipe) | |

Figure 4-2: Example of a Mud Rotary Drilling Rig

(http://upload.wikimedia.org/wikipedia/commons/8/80/Oil_Rig_NT8.jpg)

(List created by TetraTech based on: http://en.wikipedia.org/wiki/File:Oil_Rig_NT8.jpg)

Drill collars, as shown in **Figure 4-3**, are used to connect the drill bit to the drill pipe. They are thicker and heavier than the drill pipe and can vary in length. The drill collar is used to add additional weight and to stabilize the drilling string. Drill collars come in a range of diameters and weights for different applications.

As indicated in **Figure 4-2**, the ancillary equipment and support structures required to support drilling operations could include:

- Fuel sources (diesel, electricity).
- Drilling mud and additives.
- Water supply.
- Recirculation pit (mud pit).
- Cuttings handling equipment.
- Support trucks.
- Trailers for personnel work space.

The layout of the support equipment will vary based on the size and shape of the drilling pad. The rig should be placed so that support equipment and support structures

can be accessed easily without obstruction to the drilling operations. The layout should also include considerations for health and safety of the drilling and support staff. Additionally, the field equipment layout should be site-specific and comply with individual project needs.

For mud rotary drilling, a mud pit may need to be constructed near the drill rig to contain the drilling mud for recirculation through the drilling string. A shale shaker will separate the cuttings from the returned mud during drilling. Alternatively, temporary storage tanks may be used—and may be mandated—for a closed-loop drilling fluid system so that the drilling fluid and cuttings can be contained for offsite disposal.

The size of the mud pits, which are almost always lined, varies based on need and factors, such as depth of well, borehole size, volume of mud, cutting volume, etc. For example, a 35-foot by 100-foot pit was used at MGSC's Illinois Basin-Decatur test site, and a 10-foot by 20-foot pit was used at SECARB's Black Warrior test site. Depending on the volume of water needed to support drilling operations (e.g., for drilling mud), source water and flowback water impoundments may also be necessary.



Figure 4-3: Drill Collars Which Provide Drilling Stability and Weight to the Drill String

(<http://www.glossary.oilfield.slb.com/DisplayImage.cfm?ID=318>)

(Courtesy of TetraTech)

4.1.2 Drilling Methods

Current drilling methods for CCS are the same as those that have been developed and currently are used in the petroleum industry. Because of this, operators are able to capitalize on the lessons learned throughout the history of the petroleum industry for drilling wells. Several factors contribute to the selection of a site-specific drilling method, including:

- Borehole depth.
- Expected lithologies, thicknesses, and associated properties of penetrated materials.
- Anticipated borehole diameters.
- Project budget/schedule.

There are various methods used to drill wells, and some of their advantages, challenges, and applications have been provided in **Table 4-1**. In some instances, a combination of more than one drilling method can be used for a well. It is advantageous for the operator to consult regional drilling experts to know when one or more drilling method can be implemented. Some of the drilling methods listed in **Table 4-1** are more common than others, and the discussion following the table will focus on the more common methods.

Percussion Drilling

Percussion drilling methods are divided into two primary types: cable tool and air hammer drilling. The cable tool drilling is an out-of-date method and is rarely used for anything other than shallow water-well drilling, if used at all. The second percussion method, air hammer, is a faster method that uses an air hammer bit.

Table 4-1: Common Drilling Methods

Method		Comments	Application
Percussion	Cable Tool	Very simple process, but limited by equipment and formation.	Shallow water wells. Could be utilized for shallow monitoring wells in CCS.
	Air Hammer		
Auger	Hollow-Stem	Fast, but limited to certain geologies. Slow drilling, relatively cheaper.	Overburden drilling, temporary casing through unconsolidated materials. Setting shallow wells for monitoring.
	Solid-Stem		
	Bucket		
Rotary	Air	Fast, can overcome most drilling conditions. Most common method for wells several thousand feet and deeper.	Shallow to deep well drilling, vertical or horizontal. Injection and monitoring wells.
	Direct Mud		
	Reverse Circulation		
	Directional		
Coiled Tubing		Possibly faster process, ideal for directional drilling. Specialized equipment and operator needed.	Horizontal drilling.
Slimhole		Reduced materials may result in smaller footprint and cost savings. Issues with drilling torque and collar strength.	High angle or horizontal drilling.

*(Modified from a TetraTech table)

Pneumatic hammer drilling uses pressurized air that is directed to the tool through the drill pipe. The compressed air powers a “hammer” action on the bottom of the borehole while the bit is slowly turned. This pulverizes the rock into chips. The cuttings (chips) generated by the air hammer are brought to the surface using the compressed air as it leaves the drill bit and returns to the surface through the annular space between the drill rods and the borehole. Some secondary fracturing can occur around the borehole from the hammer action, which may enhance the near-hole porosity and permeability. The wells at the SECARB Black Warrior test site were drilled using an air hammer method to depths of up to 3,510 feet. Advances in this drilling technique have extended its applicability to depths of approximately 4,000 feet. Typically, the technique is limited to geologically hard rock areas in formations that have significant integrity and where excessive formation-produced water is not a problem.

Drilling with air requires the use of an air compressor. The size of the compressor(s) is important; larger compressors are required for deeper depths, large diameter holes, and for high specific gravity materials. Air hammer drilling is efficient and can be cost-effective because it is typically faster than other drilling methods. However, drilling depths are limited due to the required pressures and volumes of air needed to bring the cuttings to the surface. If significant amounts of water are generated from geologic units that have not been cased off, the accumulation of water will inhibit the return of the air and the cuttings. Additionally, if small amounts of water are encountered during drilling through fine grained geologic units such as shale, the fine dust can combine with the water and cause “caking” in the annular space between the drill stem and the borehole wall. If not removed, the “caking” can inhibit the airflow, cutting removal and possibly cause the drill stem to become stuck in the hole. Furthermore, if the hole is to be open-hole logged, it will have to be circulated with some sort of liquid drilling fluid to enable proper running, testing, and subsequent cementing of the borehole.

Rotary Drilling

This drilling method is the most common in the oil and gas industry and includes four different techniques: air, direct mud, reverse circulation, and directional. This method of drilling utilizes one of two kinds of drilling bits: fixed cutter bits (**Figure 4-4**) and tricone bits (**Figure 4-5**). Fixed cutter bits include stationary carbide tipped cutting edges, sometimes imbedded with industrial grade diamonds, commonly called Polycrystalline Diamond

Compact (PDC) bits. Tricone bits are equipped with holes between the cutting edges that allow air or cutting fluids to pass through to remove the cuttings from the hole as it is turned. The rotation speed will vary depending on the type of rock to be drilled.



Figure 4-4: Fixed Cutter Drilling Bits

(<http://origin-images.ttnet.net/en/stockboard/00/66/22/45/662245.jpg>)



Figure 4-5: Example of Tricone Rotary Drill Bit

(<http://origin-images.ttnet.net/en/stockboard/00/66/22/45/662245.jpg>)

Triconed bits are equipped with coned-shaped cutting wheels that rotate while the drill bit is rotated. The cone-shaped cutting wheels used for deeper formations are typically made of hardened steel with carbide or industrial grade diamond nubs. When turned, the cutting wheels grind and break the rock. Like the fixed-headed bits, holes/jets are located around the cutting wheels that allow drilling fluids or air to pass through to remove the cuttings from the hole.

Additional cutting wheels are typically added to the sides of the bits to assist with borehole reaming and for larger diameter holes. These bits can be used in soft to hard rocks.

Auger Drilling

There are principally three different types of auger that are commonly used: (1) large diameter bucket; (2) solid-stem auger; and (3) hollow-stem auger. In general, their use is limited to un-consolidated geology and shallow injection or monitoring wells. The advantage to using augers is their cost in relation to other drilling methods.

Coiled Tubing

This relatively new drilling method consists of using coiled tubing (CT) as the main drill string rather than inflexible steel drill pipe. CT drilling can be much faster than percussion drilling because it does not require adding or breaking joints of pipe. This technique uses a downhole mud motor rather than drilling bits and rotating tables. It is commonly used for horizontal or directional well drilling since the string is flexible and allows for greater control and precision during drilling. Using this technique, a well can be drilled without increasing the formation pressure and is used when a well is underbalanced or initial over-pressuring is not desired. The downhole drilling components, aside from the motor, may contain Measurement While Drilling (MWD) devices including formation pressure, gamma ray, resistivity, and geosteering readings, which may aid in determining formation conditions after the material has been penetrated. Additionally, CT drilling requires a smaller footprint than percussion drilling.

While CT has the advantage of a smaller footprint, it requires a more extensive construction and drilling plan to accommodate specific equipment, depending on well conditions (depth, pressure, desired drilling direction, etc.), and special blowout preventers (BOPs) and safety valves.

Slimhole Drilling

This drilling method gets its name from the finished borehole size which is smaller than the standard borehole size (typically greater than 6.5 inches in diameter). The advantages of slimhole drilling can include cost reduction and decreased environmental impact. A smaller borehole will have an even smaller footprint and will require less fluid circulation, as well as materials for casing and cementing. Studies have shown that this method results in decreased drilling time and requires smaller drilling crews and less operational equipment. A few disadvantages to slimhole drilling include reduced drilling torque due to the smaller equipment. Smaller collars and bits may require greater energy to penetrate certain formations. Additionally, collar strength and weight may become an issue with respect to deep well drilling. Certain coring, formation testing, and well logging tools may not be compatible with a smaller borehole diameter, such that data collection plans may need to be adjusted before a slimhole drilling program is initiated.

4.1.3 Drilling Fluids

Fluid-enhanced drilling, although typically slower than air, is more widely used for deep drilling. Drilling fluids fall into three groups and include water-, oil-, and synthetic-based fluids (Lake, 2006). The most common drilling fluid is water-based, but the other fluids offer characteristics that may work better in certain situations or with certain geologic units. Maintaining the permeability of the formation is critical when drilling into the target injection zone. A proper drilling fluid should be selected that will not react with the formation. Drilling fluids could potentially cause precipitates to form when the geochemical make-up of the formation and the formation water come in contact with the drilling fluids. The production of precipitates could cause a significant reduction of the permeability of a target injection formation.

Water-Based Fluids: Fresh water, sea water, or brine can be used as a drilling fluid. Depending on the borehole and geologic conditions, bentonite may be added to the water to help lift the cuttings to the surface, to reduce fluid loss, or to help maintain the hydrostatic pressure in the borehole to prevent cave-in.

Oil-Based Fluids: Oil-based fluids can include a mixture of oils or oils and water. The oils can include diesel fuel, mineral oil, or low-toxicity linear paraffins (Lake, 2006). These fluids were designed to control clays that swell

and slough into the hole when drilling with water-based fluids. The increased lubrication characteristics of the oil-based fluids can also assist in removal of stuck tools and increase penetration rates. Typically, the oil-based fluids include 10 to 20 percent fresh water, sea water, or brine. For long intervals of shale, an all-oil fluid may be used.

One disadvantage of using these types of drilling fluids is the potential for environmental impacts to water supplies in the subsurface and at the surface. As a result, oil-based fluids should not be used near potential potable water aquifers, and the cuttings and drilling fluids must be properly handled and disposed of in an approved manner. In general, oil-based fluids are not preferred for CCS injection or monitoring wells, but may be necessary under certain geologic conditions.

Synthetic-Based Fluids: In order to reduce the potential environmental impacts caused from oil-based fluids, yet still take advantage of the positive attributes, a synthetic-based fluid may be used. Like oil-based fluids, synthetic-based fluids are used to maximize penetration rate, increase the lubricating qualities in directional wells, and minimize wellbore stability problems associated with certain formations (Lake, 2006).

4.1.4 Materials Handling

There are four areas of materials handling that need to be addressed during drilling operations: drilling fluids, waste water, produced water, and drill cuttings. All of these materials need to be properly managed and disposed of during the operations. **Table 4-2** presents several recommendations for material/waste reduction, disposal,

Table 4-2: Residual Waste Management Considerations

Water Category	Reduction Strategies	Disposal Options	Beneficial Reuse Potential
Drilling Fluids	Smaller Diameter Wellbores	Burial	Recycling/Reprocessing Oil- and Synthetic-Based Muds
	Multiple Bores from Single Wellhead	Land Application	Enhanced Mud Recovery from Drilling Equipment
	Use Air	Bioremediation	
	Advanced Mud Processing Equipment Technology	Salt Cavern Disposal	
	Advanced Mud Formulas	Thermal Treatment	
Commercial Disposal			
Waste Water	Grading to Divert Rain Water Around and Away from Pad	Injection Well Disposal	Underground Injection for Future Use
		Evaporation	Underground Injection for Increased Oil Recovery
		Offsite Commercial Disposal	
Produced Water		Discharge (Generally Prohibited Except Under Effluent Limitation Guidelines for Agriculture and Wildlife Subcategory)	Underground Injection for Hydrological Purposes (i.e., Controlling Subsidence, Blocking Salt Water Intrusions, Augmenting Ground Water/Stream Flows)
		Underground Injection	Underground Injection for Increased Oil Recovery
		Evaporation	Industrial Use
		Offsite Commercial Disposal	Agricultural Use
			Domestic Use
			Road De-icing
Erosion Control (Following Separation and Treatment)			
Drill Cuttings	Smaller Diameter Wellbores	Onsite Burial	Fill Material
	Closer Spacing of Consecutive Casing Strings	Landfill Disposal	Daily Cover of Landfills
	Slimhole Drilling	Slurry Injection	Concrete and Brick Filler/Aggregate
	Coiled Tubing Drilling	Commercial Disposal Options – Including Salt Cavern Disposal	Encapsulation and Use as Road Foundation

and potential re-use based on industry best practices. Regulatory agencies typically approve material handling plans and can aid in determining specific reduction, disposal, and potential reuse procedures for a specific site.

Drilling Fluids

There are several strategies for reducing the volume of drilling fluids necessary for drilling. These include opting for smaller boreholes, using air drilling methods, and employing advanced drilling mud formulas and recovery options. Once collected, some spent drilling mud may be reusable if collected and processed using advanced recovery equipment. If drilling mud cannot be reused, then it must be disposed of or treated in an approved manner.

Waste Water

The primary mode for reducing waste water is to grade the site to avert water runoff. Waste water is usually disposed of in disposal wells, allowed to evaporate, or moved offsite for commercial treatment and/or disposal.

Produced Water

Produced water is also in many cases handled as waste water that is generated as a result of the drilling activities. These can be managed through one of three broad approaches: waste minimization, beneficial reuse, and disposal. It is important to note, however, that legal liability remains with the company who produced the waste initially, regardless of its final disposition (ANL, 2009a). Detailed approaches for drilling fluid waste management are available in **Appendix F**.

Drill Cuttings

It is important to calculate expected volumes of drill cuttings and to have a plan for their handling and disposal. A significant amount of drill cuttings can be generated, particularly in large diameter and deep boreholes. Since there are potentially a large amount of cuttings, an efficient handling system will be required to minimize disruption of the drilling progress.

The volume of cuttings is not necessarily equal to the volume of the hole created by the drilling. It will depend on the drilling method selected and the geologic material being penetrated. Typically, air rotary methods produce larger volumes of dust that has to be handled to prevent dispersal (usually with a misting system). Fluid drilling methods will typically produce larger volumes of cuttings than air rotary methods because the cuttings are captured by the drilling fluids.

The cuttings are separated from the drilling fluids using a “Shale Shaker.” They are removed and dried while the drilling fluid is re-circulated into the borehole. During this process, coarse and fine cuttings are produced. Since the coarse cuttings are comprised of ground rock with some coating of drilling fluid, they can be of beneficial use; however, analytical testing of the material may be required to ensure that any contamination present is below regulatory levels. They can be used as road base or fill material. If no specific beneficial onsite use can be established, the cuttings may have to be transported offsite to a landfill for daily cover or may be used as backfill at other sites. Local and state requirements and restrictions may place restrictions on offsite use and should be investigated during site planning.

4.1.5 Potential Drilling Issues

As with any technology, drilling operations, even though thoroughly planned, can encounter problems in the borehole that can result in significant downtime and delays in the completion of wells. Two common borehole problems are when the drilling tools get stuck or lost due to:

- Properties of the geologic units.
- Effectiveness of drilling fluids.
- Loss of circulation.
- Insufficient drill cutting recovery.
- Mechanical problems.
- Human error.

The subsurface geologic units being drilled are complex, and sometimes the drilling process introduces materials that may alter properties of the rocks resulting in a slight shift or swell in the borehole. This slight shift or swell could cause the drilling tools to become stuck, and if this occurs at a significant depth, the borehole might have to be abandoned. If the drilling fluids are not properly maintained, the borehole may become plugged, causing loss of circulation. Loss of circulation can also be caused by “takes,” where the drilling fluids enter fractures or voids and are not returned to the surface. When this happens, cuttings can accumulate in the annular space or the borehole wall can collapse, making it difficult to turn or remove the drill stem. If periodic adjustments to the drilling fluids are not made when appropriate, cuttings may not be recovered, causing accumulation in the borehole. Mechanical problems with any of the equipment can also bind the drill stem in the borehole,

such as a mechanical breakdown of the drill bit or a bent drill pipe. Human error can be reduced by using experienced drillers who can foresee problems before they occur and make the proper adjustments.

When tools become lost in the borehole, due to mechanical problems or human error, those tools have to be “fished” or retrieved from the borehole. Retrieving tools in deep boreholes can be difficult and time consuming. Several techniques have been developed over the years to help correct problems when they occur. **Figure 4-6** illustrates some examples of fishing tools that may be implemented to capture lost tools.

Failure to remove or recover lost tools can lead to significant increased costs, especially if the loss occurs deep in the borehole or near completion. Failure to recover the tools will require the drilling of a new hole, which may include re-siting of the well, or kicking off and redirecting the boring from above the stuck tool. In addition to the cost of the lost tools and fishing efforts, additional costs will also be incurred for proper closure of an unsuccessful borehole.

4.2 Formation Evaluation

Formation evaluation is conducted to test the physical and chemical properties of the rock formations. These tests include logging and testing of the geologic formations encountered to confirm the suitability of the geology at the site. The span and complexity of the logging and testing program is site-specific and the types of data gathered are dependent on locally available geologic information and regulatory mandates. Geologic information is collected at various times throughout the drilling process. Mud logs are run to collect formation and fluid characteristics of the subsurface. Core samples are used to collect information on the injection and confining zones. Drill stem tests (DSTs), reservoir tests, open-hole tests, and logging operations are used to determine downhole conditions and collect critical geologic and fluid information as discussed below.

4.2.1 Logging

Mud logging and fluid characterization analyses are commonly performed during drilling. These techniques allow a near real-time observation of the current formation being drilled via the cuttings recovered from the circulated drilling fluid. The analysis is also used to confirm the presence and depth of the various expected lithologies within the confining and injection zones.

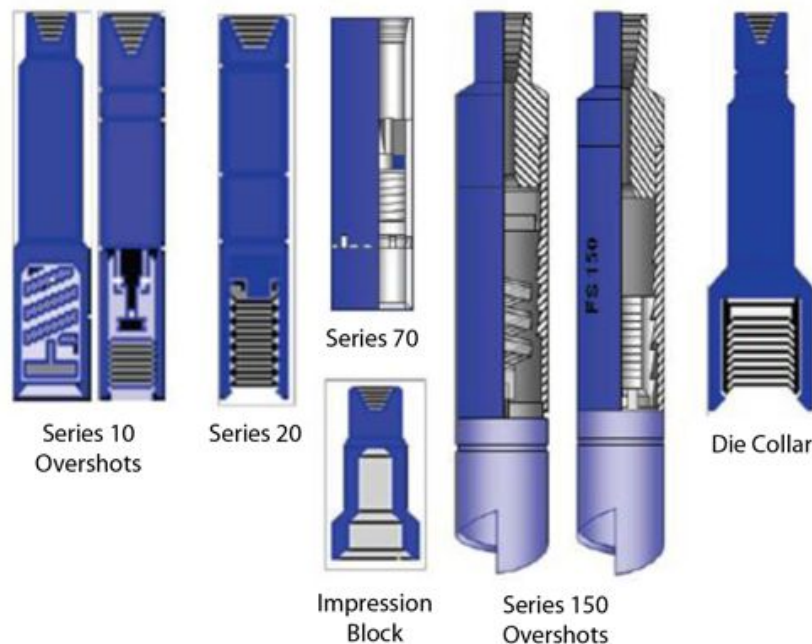

Figure 4-6: Various Fishing Tools that May be Used to Retrieve Lost Tools

(Tarton Controls, Inc., 2005)

Data collected and interpreted with logging tools provides an understanding of subsurface formation rock and reservoir properties. This understanding allows for the identification and analysis of depths and conditions for potential injection zones where entrapment of CO₂ is potentially feasible.

Table 4-3 shows several examples of logs performed by RCSP pilot projects. **Figure 4-7** shows an example of an open-hole wireline log. More detailed information regarding these logging methods can be found in the MVA Manual and in the DOE document: “Evaluation of Geophysical Technologies for Application to CCS.”

Logging packages, which have been developed to suit the needs of the petroleum industry, are also applicable to CO₂ storage projects. A variety of technologies exist which are useful for geological characterization, validation or correction of existing or vintage data, and monitoring CO₂ movement within the subsurface. While many logging service providers offer similar technologies, specific measurement applications can vary between individual geophysical tools and among service providers. A typical standard log suit often includes Gamma Ray, Resistivity, Density, Neutron Porosity, Caliper, Spontaneous Potential, and often times a Sonic log.

Advanced logging packages are also available from several logging companies and serve a much more specific purpose in augmenting the standard logging suite. A magnetic resonance log, for example, may serve to determine free moveable water within a formation, a formation imaging tool can be used to identify faults and fractures, and a capture spectroscopy log can detect elemental concentrations in the subsurface which can be used to analyze mineralogical concentrations within a formation. Oftentimes, advanced logging packages may require additional processing and/or supplementary information for interpretation. More detailed information regarding these logging methods can be found in the DOE document: “Evaluation of Geophysical Technologies for Application to CCS.”¹⁰

Logging can be conducted after the casing is cemented in place to assess the cement-to-formation and cement-to-casing bond quality. The log commonly utilized to assess these bonds is known as a CBL and will be discussed further under the Well Evaluation step. Formation and cement imaging, porosity, density, and CBLs are several types of data used to confirm that the casing and cement are properly set. Other logging instruments are designed to identify fluid flow pathways behind the casing or to assess the integrity of the casing itself. Cased hole logs

Table 4-3: Some Examples of Open-Hole Logs Performed by RCSP Projects

Logging Data Channels	Common Applications* [#]
Density	Formation Density, Calculated Porosity
Neutron	Compensated Total Porosity
Caliper	Borehole Diameter and Rugosity
Sonic	Primary and Secondary Porosity, Calculated Pore Size Dist.
Micro Imaging	Fractures and Micro Resistivity
Resistivity	Deep Formation Resistivity
Magnetic Resonance	Presence of Movable Fluid Within Formation
Elemental Capture	Presence of Multiple Elements Within Formation
Gamma Ray	Formation Natural Gamma Ray

* Further applications are possible through data processing and modeling.

See MVA Manual for further details concerning logging tools.

¹⁰ U.S. NETL, Evaluation Of Geophysical Technologies For Application To CCS Final Topical Report; Cooperative Agreement No.: DE-FC26-08NT43291, (2011).

are also utilized to correlate the depth of the injection zones with other open-hole measurements. It is noted that various factors can affect the performance and reliability of geophysical logs. For example, a washed out or rugous borehole will have a significant effect on many pad-type geophysical tool readings, such as a density log.

Logs of adjacent (or offset) wells within a study area are routinely performed to correlate injection and confining zones, determine an area's initial pre-injection conditions, and to help determine the variability and anisotropy expected to be encountered within the study area. This pre-injection data are used to help model and

estimate future plume migration or reactions caused by the presence of entrapped CO_2 . Monitoring wells are often logged and routinely checked for detection of CO_2 migration and formation integrity during the lifetime of the injection project. **Figure 4-8** shows how open-hole logs may be correlated to develop a stratigraphic cross-section.

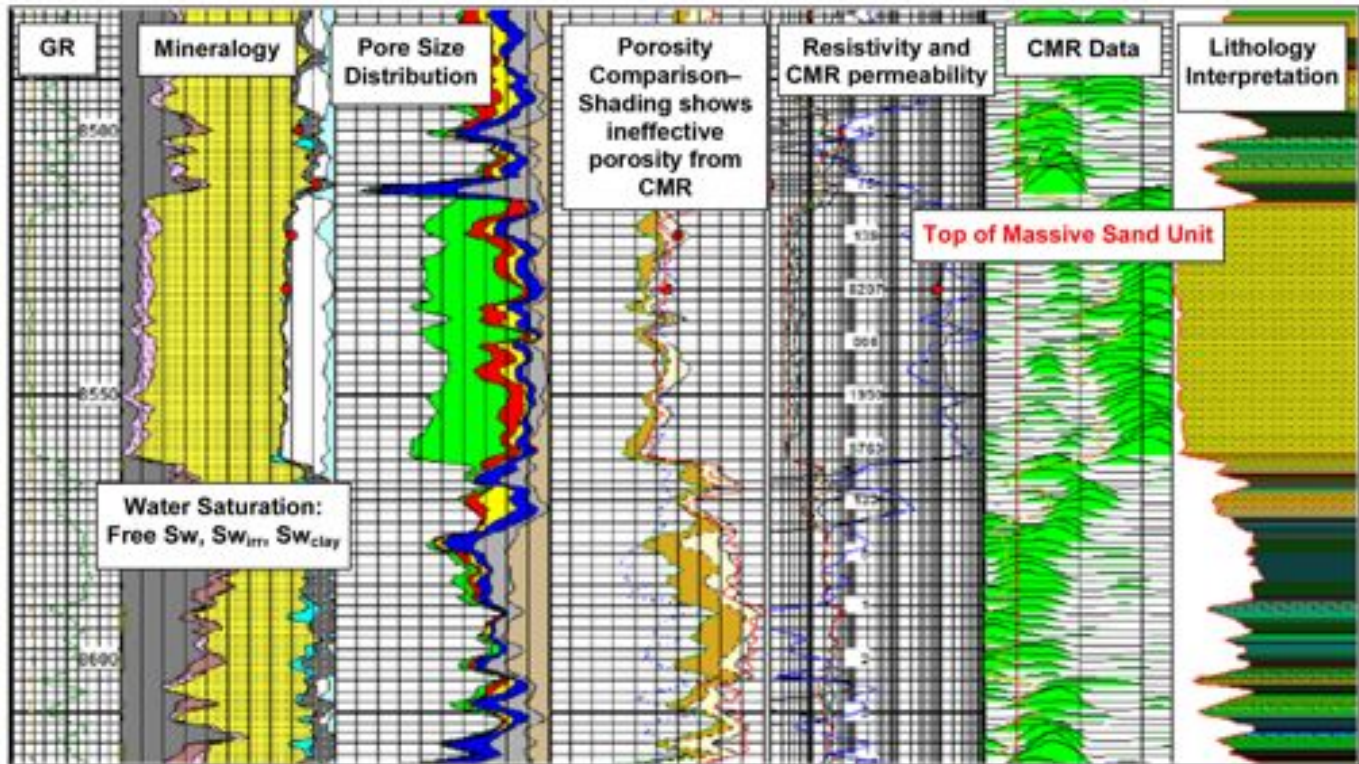

Figure 4-7: Example of an Open-Hole Wireline Log

(SECARB, Final Report: Plant Daniel Project Closure Report, Volume 1 of 2, 2010)

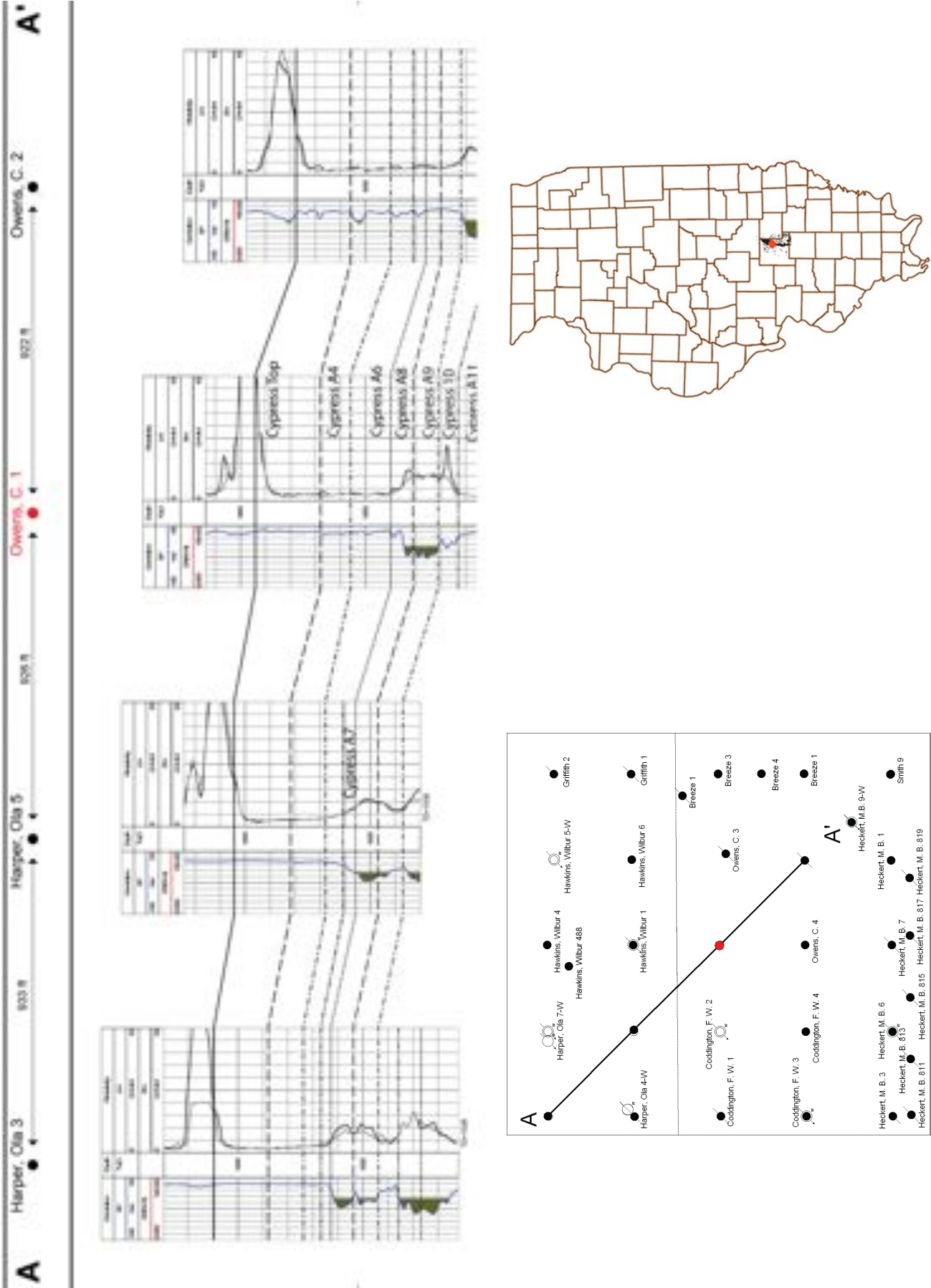

Figure 4-8: Example of Open Hole Logs (Owens, C.1) Used to Construct a Cross Section

(MGSC, Enhanced Oil Recovery I: Loudon Single-Well Huff 'n' Puff, Final Report, October 1, 2005 – September 30, 2009, pg. 9)

4.2.2 Coring

Core samples, specifically whole rock cores, can provide data on both the confining and injection formations. Cores allow for physical and chemical inspection and analysis of key properties of the zones being considered for storage. Chemical core analysis may help predict potential long-term reactions due to CO₂ injection. There is a provision in the U.S. EPA Class VI UIC permit which indicates that regulators can request information about the geologic properties of sealing formations. Therefore, it is recommended that regulators be contacted during the development of a coring program.

Coring Techniques

There are three methods of collecting rock cores. The first two methods, conventional coring and wireline coring, both require the use of a core barrel that can be 10 to 60 feet in length. The core barrel is equipped with a diamond studded bit that is hollow in the center (**Figure 4-9**). As the drill string is rotated, fluid is circulated through the center of the drill pipe and core barrel to cool the bit and remove the cuttings. As the drill string is advanced, it cuts the rock and the core sample slides up the center of the barrel into an inner barrel or sleeve with a retaining device. There are a number of core barrel types that range in diameter from one to six inches.

For conventional coring, the core barrel (typical cores are 10 to 30 feet in length but can be longer) is attached to the end of the drill string and lowered to the bottom of the hole. Once the run has been completed (the length of the core barrel has been drilled), the drill string is removed from the borehole and the core is extracted from the barrel assembly either onsite or at the core analysis laboratory. This method requires an appropriate amount of rig time because the drill string has to be removed from the hole (tripped out) to retrieve each interval of drilled core.

Wireline coring is similar to the conventional coring, except that the inner core barrel is retrieved without removing the entire drill string. Once the run has been completed, a “messenger” attached to the end of a wire cable is sent down the interior of the drill string. When it reaches the top of the core barrel, it unlocks and attaches itself to the inner core barrel. The wire is retrieved and the inner barrel is brought to the surface. Once the core has been extracted, the inner barrel can be sent back down the drill string to collect another sample. This method is effective in deep boreholes where several consecutive runs are required. This method can significantly reduce drilling times because the drill stem does not have to be removed to retrieve each core.



Figure 4-9: Core Bits

(<http://en.wikipedia.org/wiki/File:Diamondcorebits.jpg>)

The third coring method is sidewall coring. This method involves a rotary bit or percussion coring tool that is lowered into the borehole to selective depths after the borehole has been drilled. A small core (typically around one-inch diameter) is collected from the side of the borehole and the core sample is stored in the tool so multiple samples can be collected from each run. For example, the Midwest Regional Carbon Sequestration Partnership (MRCSP) collected 48 sidewall core samples at the R.E. Burger Site in two sampling runs. One benefit of this method is that it allows for the economical collection of rock samples from multiple levels in the well after a basic logging suite has been collected. In addition, it is an economical method to assess formations that have not been encountered before. Sidewall cores can be targeted, for example, for specific porous intervals that may represent a potential injection zone. A limitation of the method is that the core is not continuous, so small-scale changes in lithology could be missed. Oftentimes it is beneficial to run a microimaging log to supplement sidewall core data. Another limitation of sidewall coring is that the small sample size can increase the uncertainty in some laboratory measurements of rock properties.

4.2.3 Drill Stem Testing

Well tests that are conducted with the drill string still in the hole are referred to as drill stem tests or DSTs. DSTs are performed to determine the types of fluids in the formation and to estimate production, injectivity, formation pressure, permeability, and relative formation damage. More specifically, DSTs are used to:

- Evaluate the formations of interest before casing and completing the well so that these costs can be avoided if formation properties turn out to be unsatisfactory. WESTCARB used this approach at the Cholla well in northeastern Arizona. A DST showed that the target reservoir formation had negligible permeability, so the well was abandoned without incurring most of the casing and completion costs (Myer, et al., 2010).
- Test the well with minimal environmental impacts at the surface because there is little or no release of fluids.
- Collect data that can be used to standardize and correlate with logs that are run in the wellbore.

A DST uses temporary downhole packers to isolate the zone of interest. Valves control the production of reservoir fluids into the drill pipe and to control the flow time. Following the test, the equipment is retrieved from the well. The analysis of the test results is typically undertaken using generally available software packages or standard methods published in reservoir engineering textbooks.

4.2.4 Reservoir Fluid Testing

Samples collected from the well are typically sent to a laboratory for analysis and fluid characterization. Field service companies may also provide field laboratory equipment to achieve immediate results. MGSC contracted a field service company to run a DST in a formation above the targeted storage reservoir to determine order-of-magnitude total dissolved solids (TDSs).

Typically, fluid samples are retrieved and maintained under in-situ conditions and then analyzed at the laboratory. Some tools have built-in downhole fluid analysis capabilities which were primarily developed to determine when a representative fluid sample, uncontaminated by drilling fluids, was present in the flow line prior to sampling. Typically, they consist of optical spectrometry, resistivity measurements, and fluorescence, which has the ability of compositional analysis and hydrocarbon typing but are only able to see limited elements when compared to laboratory testing. In-situ fluid properties can also be determined using advanced downhole tools. This process allows for near laboratory-quality fluid analysis directly in the formation. Typical properties of interest are fluid density/viscosity, chemical composition (TDSs, presence of CO₂, sulfur, etc.), fluid pressure, and temperature. The subject of reservoir fluid chemistry has received considerable attention given its impact on the efficacy of EOR operations.¹¹

Important issues in fluid testing for reservoirs under consideration for carbon storage include fluid-compatibility effects, the products of reactions (e.g., emulsions and scales), and the precipitation of the dissolved solids (e.g., salt). The testing of the reservoir fluids is crucial for determining potential workovers/treatments that may be

¹¹ Mullins, O.C., 2008, The physics of reservoir fluids – Discovery through downhole fluid analysis: ISBN – 10097885302-4 is an excellent reference for downhole fluid analysis.

required to maintain the operating efficiency of an injection well(s). Additionally, fluid analysis results can be utilized by models to better determine scenarios for injection and post-injection. Potential issues with injection pressure, CO₂ dissolution, and plume distribution can be assessed prior to injection operations based on the results of fluid testing.

4.2.5 Open-Hole Testing

Open-hole tests are used to develop injection parameters and strategy. Common methods include DSTs, wire-line formation tests, and step-rate injection tests. DSTs and wire-line formation tests can be utilized to calculate the reservoir pressures in potential injection formations. Step-rate injection tests go a step further and can be employed to determine the fluid-formation pressures expected during injection. In this approach, brine or a native formation fluid is injected at increasing rates and pressure increases are monitored in the well and injection lines (and possibly nearby monitoring wells). By monitoring the change in formation backpressure, it is also possible to determine permeability parameters. For additional information, see Matthews and/or Earlougher.^{12,13}

4.2.6 Evaluating the Suitability of the Formation

After the borehole is drilled and the appropriate suite of tests has been conducted and analyzed, the operator reaches a decision point (indicated by the first red decision point in **Figure 4-1**) regarding the suitability of the potential reservoir for the intended project purpose. If the results indicate changes in the Detailed Site Development Plan are warranted, the operator should decide whether to proceed with the project and if so, make the appropriate changes before going onto the next phase, Well Construction. This is an important decision point and could lead to costly delays if not thoroughly carried out.

4.3 Well Construction

This section focuses on casing strings, cementing, and wellhead equipment. Well construction practices in CCS are similar to or based upon standard practices in the petroleum industry even though there are different regulatory requirements. The new EPA UIC Program construction requirements include standard construction and performance requirements for Class VI wells for injection of CO₂.¹⁴ Well construction and completion costs may prove to be a large factor in the project due to casing and cement in the injection well. Completion costs will be dependent on the purpose of the well, technical specifications, and requirements of the EPA UIC Program.¹⁵ In addition, any costs associated with well stimulation will need to be included.

Table 4-4 presents a summary of some American Petroleum Institute (API) and American Society for Testing and Materials (ASTM) Well Construction Specifications. API specifications cover all aspects of well construction, but ASTM only covers a specification for the type of well cement. Several private companies have developed guidelines and manuals for well construction and intervention.

In general, materials selected for the construction of CO₂ injection wells (e.g., casing, tubing, cement, completion hardware) need to be non-reactive to the native groundwater or brines. In addition, they must be non-reactive to the CO₂ stream or any acid-gas impurities being injected, and to the CO₂-saturated reservoir fluid. The following section describes some of the common well materials.

4.3.1 Casing Strings

Installation of casing strings occurs at discrete points during the well construction process. Casing strings are used to maintain borehole integrity during drilling, assist in the drilling process, and protect against unwanted migration of fluids and gases (e.g., into shallow groundwater). Casing strings are installed in a telescoping fashion, from the largest diameter at the

¹² Matthews, C.S., Russell, D.G., 1967, Pressure buildup and flow tests in wells: SPE Henry L. Doherty Series Monograph, v. 1, ISBN 978-0-89520-200-0.

¹³ Earlougher, R.C., 1977, Advances in well test analysis: SPE Henry L. Doherty Series Monograph, v. 5, ISBN 978-0-89520-204-8.

¹⁴ A detailed discussion of the six existing UIC well classes is available on EPA's UIC website (<http://water.epa.gov/type/groundwater/uic/wells.cfm>).

¹⁵ Please see the EPA UIC Program website for additional information: <http://water.epa.gov/type/groundwater/uic/index.cfm>.

Table 4-4: API and ASTM Well Construction Specifications

API Specification	ASTM Specification	Construction Application
5CT		Casing and Tubing
5L		Line Pipe
6A		Wellhead and Christmas Tree Equipment
6D		Pipeline Valves
10A	C150	Well Cement
10D		Bow-Spring Casing Centralizers

surface to the smallest diameter at the greatest depth. The number of required casing strings is dependent on the geologic formations being penetrated, the depth of the well, and by state and Federal regulations. It is important to have accurate geological information so that the proper number of casing strings can be included in the well design prior to drilling.

Typically, the first casing, known as the conductor casing, is set to a shallow depth and is large to prevent the collapse of the loose soil near the surface during drilling operations, prevent surface erosion caused by drilling fluids, and provide strength for installation of wellhead equipment. This initial casing needs to have a large enough diameter to accommodate the additional concentric casing strings that will be installed as the well is completed. The second casing, the surface casing, is set deeper (hundreds to thousands of feet) with the primary purpose of isolating USDWs from deeper formations. Once the borehole is advanced through the overburden material, the casing is placed in the hole and cemented in place from the bottom up in the annular space between the casing and the borehole. Once the cement has cured, drilling with a smaller diameter bit can continue through the surface casing.

Intermediate casing is used to prevent hole collapse in weak formations, isolate different zones that may have different pressures and water chemistry, and to allow different density drilling fluids to control lower formations. Although EPA establishes casing material requirements as part of their groundwater protection efforts, the casing grade should be carefully selected by a drilling engineer based on geologic conditions. A variety of materials, alloys, and coatings are available to address corrosion of well casings and tubing. Injection casing and tubing are classified by API type of steel (H-Q) and minimum yield pressure (40-125+ thousand pounds per square inch). In general, higher grades of steel are designed for deeper

wells, higher temperatures, higher pressures, and corrosion resistance. Many grades of steel are designed to be more ductile to prevent brittle failure from hydrogen sulfide (H_2S) gas, also known as “sour gas.”

Carbon dioxide is referred to as “sweet gas” when encountered in the oil and gas industry and can cause pitting and pinhole leaks in casing, joints, tubing, and packers. Typically, an API grade of L-80 or greater is used for these applications. If the nitrogen dioxide (NO_2) and sulfur dioxide (SO_2) result in a similar acidic corrosion process, then the same grade of steel may be sufficient for these compounds as well. Other options for corrosion resistance include alloy plating (nickel, chrome, etc.), polymer coatings, stainless steel, and fiberglass casing. These options are typically more expensive and more difficult to handle in the field and are susceptible to damage. Many operators use common steel grades (J-55) with few problems, so long as they produce or inject relatively pure CO_2 . Some EOR fields encounter significant corrosion when injecting water alternative CO_2 gas. The partnerships used many different grades of casing to meet the various conditions in which wells were located.

Each successive casing interval is cemented in place as described above and drilling continues with progressively smaller and smaller bits. Stabilizers, or “centralizers,” are installed around the casing, particularly at depth, to keep the casing string centered in the hole. If stabilizers/centralizers are not used, the casing string could rest along the borehole walls and prevent a proper seal with cement. The lack of stabilizers/centralizers may also result in difficulties with insertion and retrieval of the drilling tools.

The final string of well casing, the injection casing, inner casing string, or “long string casing,” is run into the wellbore and set at or near the bottom of the borehole. The final string is equipped with centralizers to center the casing

string in the borehole and maintain a sufficient annulus for cement placement around the casing string. Cement is placed in the annular space using the displacement method that is common in completion of oil and gas

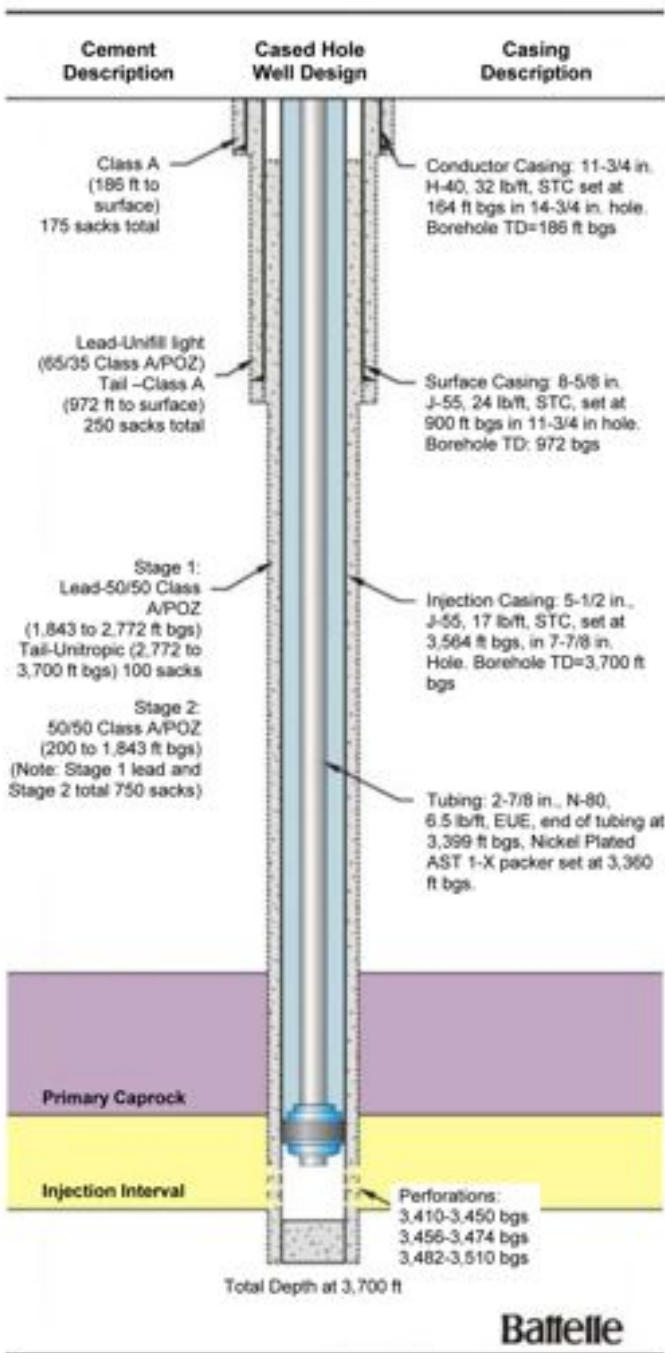

Figure 4 10: Example of a Multiple Cased Well
(Modified Image from “Fact sheet for Partnership Field Validation Test, MRCSP, Cincinnati Arch Geologic Test, 2009, by Battelle)

wells. The casing string and surrounding cement can then be perforated at the target formation interval to establish communication between the casing and the formation.

As mentioned previously, the construction of CO₂ injection wells is similar to the construction of oil and gas wells; however, CO₂ injection wells face additional regulations under the EPA UIC Program. For example, the casing strings should contain suitable casing materials and the inner casing in and near the injection zone must be constructed with corrosion-resistant material (e.g., chrome alloy steel, stainless steel). **Figure 4-10** presents an illustration of an injection well with conductor, surface, and injection casing strings set to various depths.

4.3.2 Cementing

EPA UIC requirements for cementing the casing strings vary by well type. Typically a cement design for the specific well is developed prior to starting the well installation. The design is usually based on information from nearby wells and from information collected during the drilling of the well to be cemented. There are several key elements that have been identified for proper cementing. First, the wellbore should be prepared for cementing by circulating drilling mud in the hole to condition the wellbore. Second, the casing string should be properly centralized to assure complete cement coverage of the annular space between the casing and wellbore. Third, the cement should comply with the appropriate API and ASTM specifications. Typically, Class A cement is used in many applications. However, other API class cements have been designed that are applicable in wells with elevated temperatures and environments where acidic conditions are present and the cement is designated as CO₂-resistant. Finally, given that cement slurry is prepared onsite, it is crucial that the water used for mixing and displacement be clean and free of organic materials such as leaves or agricultural wastes. There should also be no free water within the cement slurry which may form voids when dried. Typically, these details are managed by the company providing the cementing services; the operator should be aware of these requirements and may want to ensure that the cement service company is assessing the impact of formation fluids on the cement being used.

4.3.3 Wellheads

The wellhead consists of components installed on the top of the casing strings at the surface and will vary depending on the well’s function (e.g., injection or monitoring). For injection wells, the wellhead allows for the regulation and monitoring of the injected CO₂

into the well. It also prevents leakage of CO₂ out of the top of the well, and prevents blowouts due to high pressures that may be present in the formations. The wellhead is typically designed to withstand pressures up to 10,000 psi or more. The wellhead is made up of two “heads,” a casing head and a tubing head. The configurations shown in **Figure 4-11** is representative of a typical injection wellhead design. The casing head is a flanged fitting that is connected to the surface casing and provides a seal between the casing annulus and the atmosphere. The tubing head is also a flanged fitting. It is used to support the tubing and to seal off pressure between the casing and the outside of the tubing.

A monitoring wellhead can be similar to the injection wellhead. The well completion, including perforations and fluid sampling ports, should accommodate the planned monitoring techniques. **Figure 4-12** illustrates a standard monitoring well minus the tubing and packer.

Construction of both wellheads should conform to API specifications listed on **Table 4-4**, as well as any other regional requirements. Care must be exercised in selecting the API grade of tubing given the potential for the formation of acid when CO₂ and water mix. Typically, the

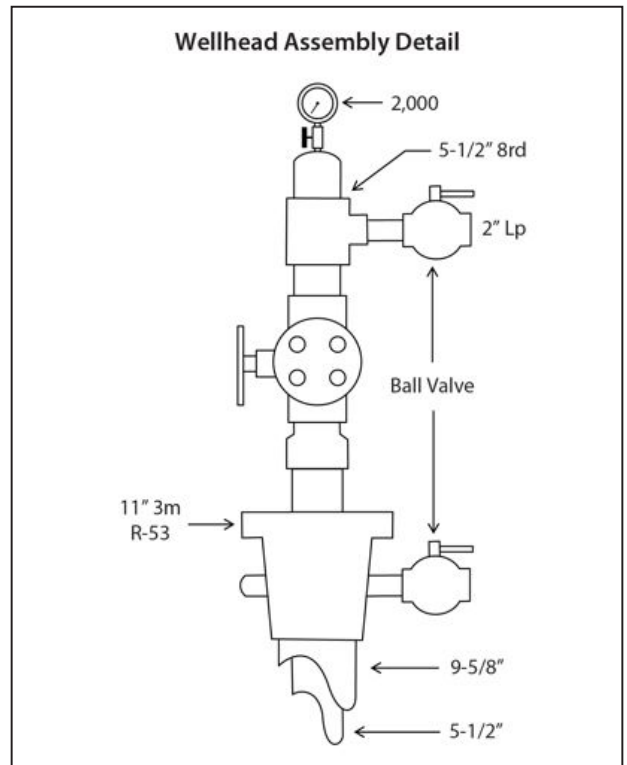

Figure 4-12: Example of a Monitoring Wellhead Assembly

(SECARB, Summary Sheet, SECARB, Mississippi Test Site – Plant Daniel, 2010)

lower the carbon content of steel used, the longer the life of the tubing string used for the injection of CO₂. For this reason, consideration should be given to the pipe grade.

In the configuration illustrated in **Figure 4-10**, the tubing is set on a packer. Typically, the packer is a retrievable packer that permits the tubing to be set in tension and allows the removal of the tubing if problems or wear appear during use. This type of packer is common to the oil and gas industry and is used in multiple applications such as injection wells and production wells.

4.4 Well Testing

Prior to injection, it is necessary to perform several tests to assess the quality of the well construction. These tests are able to determine if further rework is required to fulfill regulatory well requirements and optimal casing conditions for injection. These tests include using a CBL to identify and evaluate the cement sheath around the casing. As discussed in the logging and formation testing section above, CBLs are typically run after the long-string casing is cemented. They are indicators of

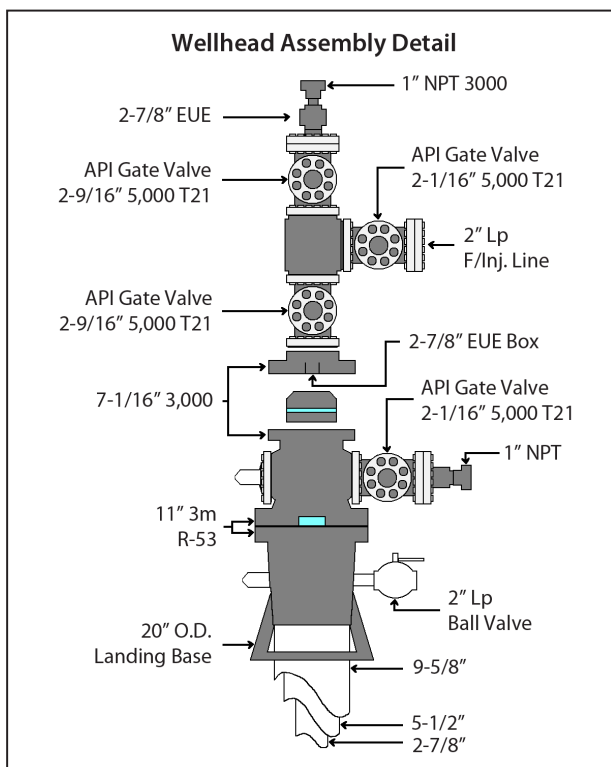

Figure 4-11: Example of an Injection Wellhead Assembly

(SECARB, Summary Sheet, SECARB, Mississippi Test Site – Plant Daniel, 2010)

the quality of the cement bond between the casing and formation. A high-quality cement bond in and above the injection zones is an important means of preventing CO₂ from migrating through the annulus into a USDW.

Figure 4-13 is an example of a processed CBL-VDL plot. This log records transit time and attenuation of an acoustic wave propagated into the bedrock through the borehole fluid, casing, and cement. The percent bond estimation is graphically shown on the first track (CBL-BI). Amplitude (CBL) and attenuation (CBL-ATTN) are shown in the third track. High signal amplitude indicates poor cement bond, as much of the energy is retained by the casing. The variable density waveform (VDL), displayed in the fifth track, helps to detect the presence of channels between cement and bedrock. The calculated cement compressive strength (CBL-COMP) is shown on the last track.

The CBL-VDL log in this example can be interpreted as having intermittent or partial cement in the top half (mid to high amplitude, no clear formation signals in VDL, mid- to low-calculated bond index), while the bottom half shows good cement bond (low amplitude, clear formation signals in VDL, mid-high bond index). Note that additional factors may be needed to properly interpret a CBL-VDL log (well/formation pressure, formation composition, etc.).

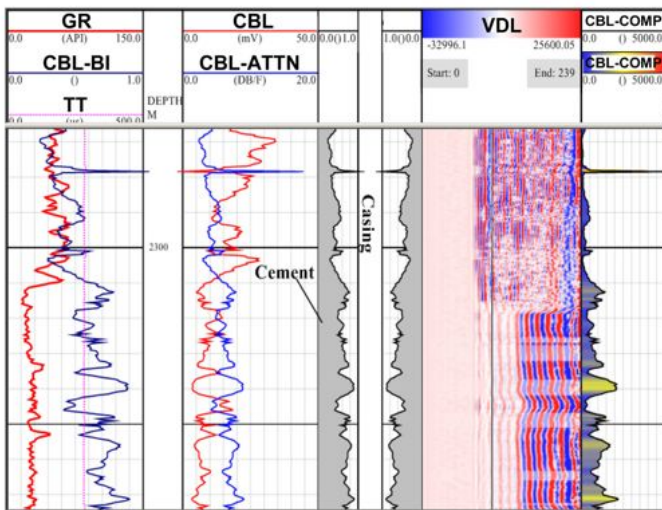

Figure 4-13: Example of a Processed CBL-VDL Log;
Courtesy of Petrolog.net

(http://www.petrolog.net/webhelp/Graphics/Plots_Misc/Sonic_Array.htm)

Another set of tests, referred to as Mechanical Integrity Tests (MITs) are conducted after the well is completed to demonstrate that it has internal and external integrity. Internal MITs are used to determine if there are any leaks in the well tubing, casing, and packer. External MITs are used to determine if there is significant movement of fluids, possibly to a USDW, through vertical channels adjacent to the wellbore. For Class VI wells, EPA requires an initial annulus pressure test and then continuous monitoring of injection pressure, rate, and injected volumes; pressure on the annulus between tubing and long-string casing; and annulus fluid volume as specified in the regulations under 40 CFR Part 146.88 (e). Further, at least once a year, the operator must use an approved method, such as a tracer survey, an oxygen-activation log, or a temperature or noise log, to demonstrate mechanical integrity. Other potential MITs include a casing inspection log or an alternative method that provides equivalent or better information and that is approved of by the EPA Director.

The process of well evaluation is indicated by the second red decision point adjacent to the well evaluation box in **Figure 4-1**. This process will lead to the revision of the Drilling and Completion Operations by a required one (or a combination) of three possible actions: (1) re-evaluate project plans, (2) revise well conditioning plan and re-condition wells, and/or (3) proceed with pre-injection baseline monitoring. The best case scenario would yield an “affirmative” decision point of suitable results, leading to the initiation of pre-injection baseline monitoring. Any resulting decision other than an affirmative would lead to a re-evaluation of the conditioning plan and possibly the project plans.

4.5 Determining the Suitability of a Well

Once it is demonstrated that the well has been completed properly, all integrity issues have been resolved, and the well is situated in an area of the injection formation which is suitable for injection, it can be incorporated into the project. If the well evaluation indicates that there are concerns, the operator will need to consider whether the well can be reworked or if the injection zone can be relocated to a different interval within the wellbore. If this is not possible, the wellbore might be reconfigured for an alternate purpose, such as monitoring, or be abandoned. Throughout the lifespan of a well, the operator should conduct a number of checks and tests to determine that the well is still suitable for the planned use.

5.0 Injection Operations

Injection Operations includes three steps: Pre-Injection Baseline Monitoring, Injection System Completion, and Injection. Pre-Injection Baseline Monitoring is used to establish baselines. Injection System Completion is the step in which the final equipment is selected and installed. Injection can be categorized in three stages: Startup Operations, Routine Injections, and Routine Field Operations. The initial stage (Startup Operations) involves pressuring up the well by gradually increasing the injection rate to the planned rate, not exceeding the permitted formation pressure. The planned injection rate might not be achieved for an extended period of time as the entire system comes online. The injection rate is dependent on the properties of the injection formation. Once the injection well(s) is operating as expected, it will enter the Routine Injection stage. Routine Injection could continue for weeks to years, depending on the site-specific conditions and planned injection program. During Routine Injections, the well integrity and the subsurface conditions will be monitored. The third stage (Routine Field Operations) is reserved for potential well activities that are not considered either Startup or Routine. For example, this could involve temporary idling of the well, temporary shutdown due to system interruptions (e.g., CO₂ source or pipeline issues), or well issues needing remedial actions.

5.1 Pre-Injection Baseline Monitoring

Prior to the injection of CO₂ into the target zone, pre-injection monitoring is used to establish a baseline for injection and post-injection monitoring. Typically, baseline data is acquired in the surface, near-surface, and subsurface using a variety of tools and techniques. Monitoring techniques are constantly evolving as new technologies are developed. For more in-depth discussion on monitoring tools and techniques, please see the MVA Manual (http://www.netl.doe.gov/technologies/carbon_seq/refshelf/MVA_Document.pdf).

5.2 Injection System Completion

Throughout the well management activities, the type and amount of plant equipment that occupies an injection site can vary. During Site Preparation, the operator installs the primary surface infrastructure to support the multiple stages of well management activities such as site grading, roads, and major onsite pipelines. During the Drilling and Completion stages, additional equipment is moved onsite for those activities; some equipment is then removed and replaced with equipment used for injection operations. In preparation for Injection Operations, both standardized equipment that is common to all injection operations and specialized equipment necessary for specific injection plans are installed onsite. Injection site configurations can be variable depending on the existing infrastructure, subsurface conditions, and operations in the region. For example, a typical configuration might consist of a pipeline leading to one single injection well or it could also include compression/dehydration system, multiple pipelines to wells, and a support building. Although each site is different, the equipment used during the operations is generally the same.

5.2.1 Standard Equipment

Each installation of surface equipment is unique to the project. There are, however, some typical or standard equipment that is generally encountered or used. **Figure 5-1** shows the equipment used at SECARB's Southwest Virginia Phase II injection site.

The type, size, and manufacturer of injection equipment will be site-specific based on characteristics such as source stream of CO₂, the reservoir type, and geologic conditions. The equipment should be designed to handle the required injection pressures and flow rates necessary during injection to meet the required objectives of the project. The types of equipment and infrastructure to be discussed in this section that relate to the wells may include:

- CO₂ Pipelines
- Compression/Dehydration System
- Valves
- Injection Control/Monitoring Equipment
- Alarms/Control Limits
- Collection Ports
- Support Buildings

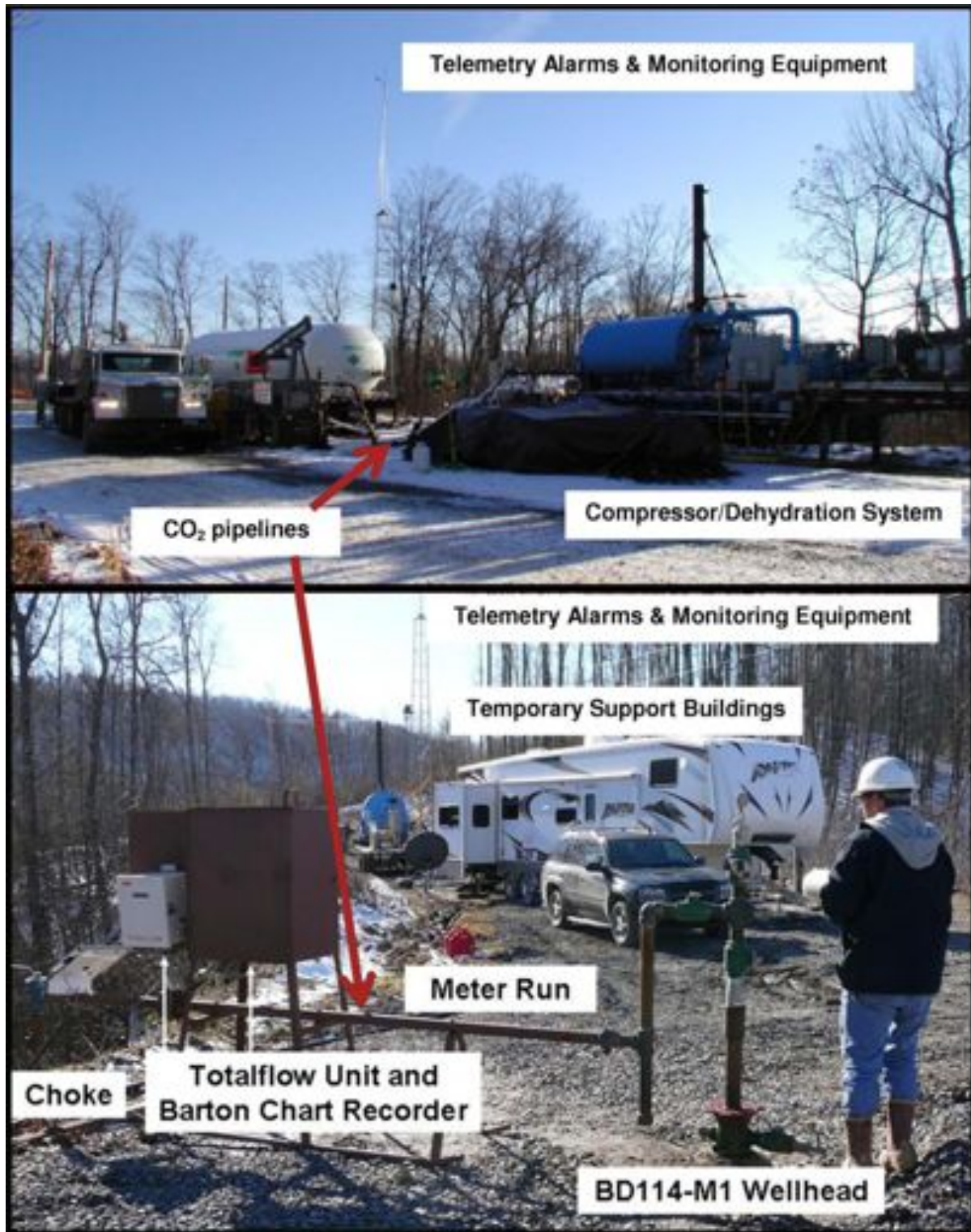

Figure 5-1: Standard Injection Equipment
(SECARB, Advances Resources International, Inc. 2011)

CO₂ Pipelines

The CO₂ pipeline infrastructure for a CCS project is analogous to the infrastructure for natural gas pipelines. There are three primary types of pipelines used to transport CO₂ via pipeline:

- **Gathering Lines:** Pipelines that transport CO₂ from multiple point sources and connect into a main Trunkline.
- **Trunklines:** The main pipelines that transport CO₂ collected from various gathering lines before arriving at the distribution lines.
- **Distribution Lines:** Pipelines that transport CO₂ from the Trunklines to the storage fields and wellheads.

As discussed in this manual, the focus is on the use of distribution lines taking CO₂ from Trunklines to the storage field for further distribution to the wellheads, or, in the case of onsite CO₂ sources, for direct transport to the wellhead(s).

Carbon dioxide gas is corrosive when mixed with water; therefore, before it enters any pipeline, CO₂ may need to undergo a dehydration process to avoid possible

condensation, and the CO₂ pipelines may also need to be constructed of non-corrodible materials. The petroleum industry has developed significant expertise for both dehydration and pipeline construction and maintenance. Typical pipeline materials include various types of metals and fiberglass. Some operators use 316 and 410 stainless steel for meter runs and piping, and fiberglass for surface facilities. Other operators find the corrosion rate acceptable with carbon steel pipe if there is minimal water in the system and/or water is injected infrequently. Water accumulation within the system can increase corrosion rates and damage sensitive equipment. In these cases, it may be beneficial to install water drop-out traps or legs where any excess fluid can be collected. These pipe legs can then be sealed and drained, thereby eliminating the potential for pipe damage.

The CO₂ distribution lines or distribution system at the injection site needs to be designed for the nature of the CO₂ being injected (i.e., carbon steel may be acceptable if the CO₂ is dry, ideally containing less than 50 parts per million [ppm] of water¹⁶). The distribution system should include check and isolation valves (**Figure 5-2**), metering equipment, control valves, pressure sensors and switches, gauges, and pressure relief valves that also need to take the characteristics of the CO₂ into account. API standards for CO₂ valves can be useful for planning.¹⁷

Figure 5-2 is a close-up illustration of an injection wellhead.

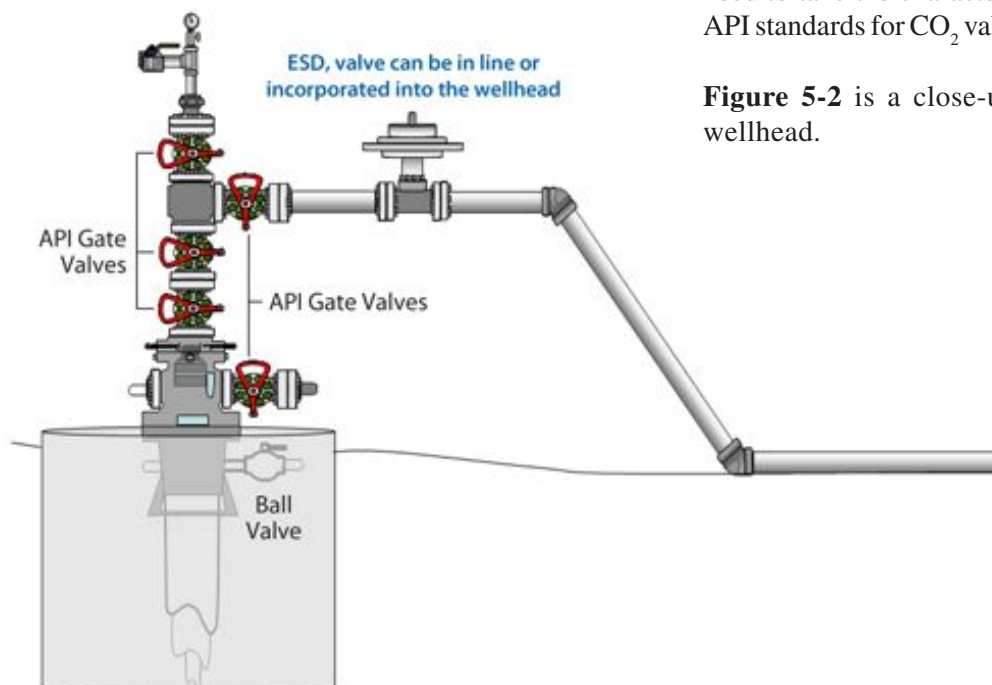

Figure 5-2: CO₂ Injection Wellhead with Emergency Shutdown (ESD) Valve

¹⁶ “Summary of Carbon Dioxide Enhanced Oil Recovery (CO₂ EOR) Injection Well Technology,” prepared for the American Petroleum Institute by James P. Meyer, PhD, Contek Solutions.

¹⁷ Spec 6D/ISO 14313

Surface injection equipment must be rated for CO₂ pump pressures, which can range from 500 to 3,000 psi. Many companies utilize horizontally mounted surface centrifugal style pumps (electric submersible pump [ESP]-type) for CO₂ injection since the fluid is handled in a liquid state. In some applications, a line heater may be required to maintain the fluid at an acceptable temperature to prevent freezing of the surface equipment. As the CO₂ is pumped through meter runs and other restrictions, the pressure drops occur, which results in cooling that may freeze and constrict the distribution lines. The design of the CO₂ handling equipment should account for this phenomenon.

Compression/Dehydration System

Depending on the condition of the CO₂, a compression and or/dehydration system may be required to remove water and compress the CO₂ to a dense state prior to injection. The size of the compressor(s) will be dependent on the scale of the injection. **Figure 5-3** presents a schematic of a typical compression/dehydration system developed for the MGSC Decatur Site injection project.

Valves

The placement of valves is important for successful injection operation and safety. Valves should be placed to assist in the equipment operation and can be used to help gate and control the injection flow rate. The valves are also used to shutdown the well(s) between injection periods and when the injection is completed, prior to proper sealing of the well. During emergencies, the valves should be easily accessible so that the system can be quickly deactivated. The valves can come in different types and can be manually or electronically operated. The emergency shut-off could be electronically operated, but should also have the option of a manual override if needed.

The injection wellhead assembly in **Figure 5-4** (also shown as **Figure 4-11**) illustrates some typical valves that may be used for CO₂ injections. The valves should be adequately sized for the piping, be compatible with CO₂, and be able to handle the design pressures and flow rates. Standard ball valves should also be ported.

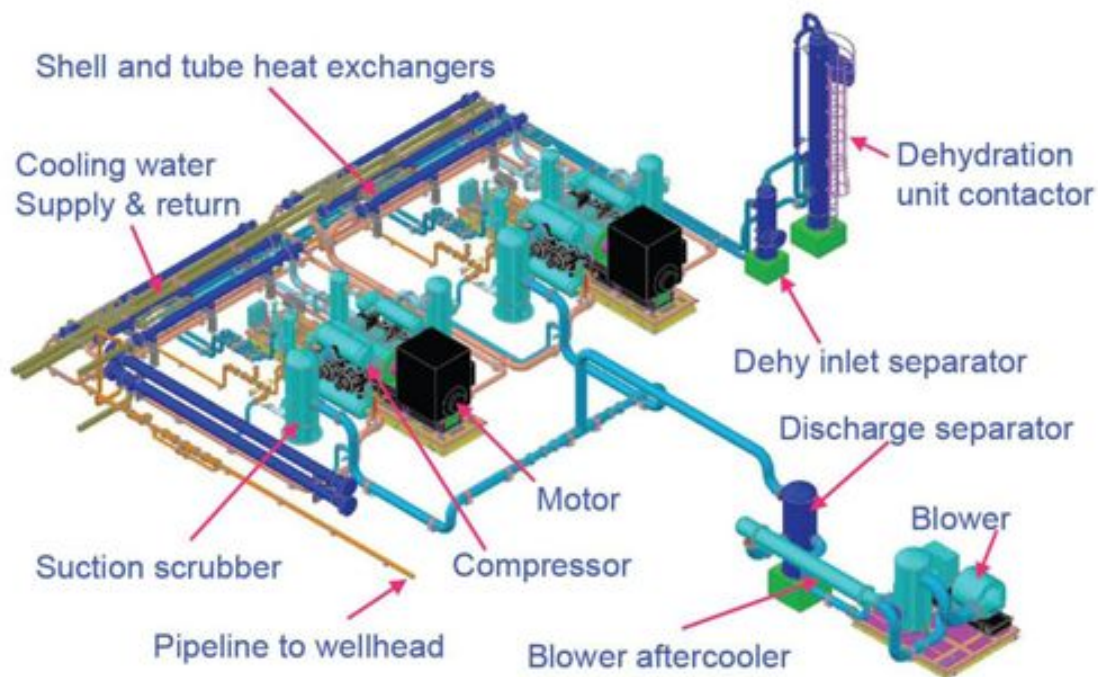

Figure 5-3: MGSC Decatur Site Phase III Compression/Dehydration System

(Image Courtesy of Trimeric Corporation and MGSC)

Emergency relief valves will also need to be installed. If injection pressures exceed safe operating conditions, the emergency valve will open and vent the excess pressure to the atmosphere. This will prevent damage to the system. The emergency relief valve should be placed in a safe location where personnel will not be exposed if the valve is activated. Additionally, pipeline sections might have to be closed for repair or general maintenance; therefore, the system should also have appropriate valves to isolate and relieve pressure as needed.

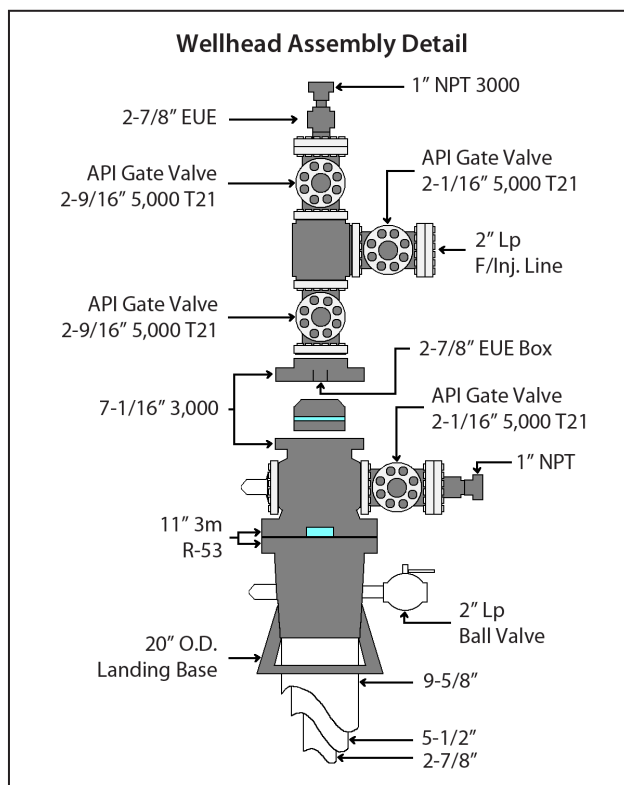

Figure 5-4: Typical Valves Found in an Injection Wellhead Assembly

CO₂ Injection Control and Monitoring Equipment

Injected CO₂ will be monitored during injection and post-injection phases to validate that formation pressures and injection rates (among other parameters) and ensure compliance with regulatory requirements. For CO₂ injection wells, control and monitoring equipment typically focus on storage formation injection pressure in the injection well(s) and in monitoring wells. Downhole formation pressure is monitored to prevent injection pressure from reaching or surpassing the maximum

allowable limits as determined during the UIC permitting process. The intent is to avoid fracturing the injection and confining zones. Pressure gauges are commonly used to collect these measurements. The gauges should be properly placed in the system so that critical areas can be continuously monitored and allow for some redundancy. Typically, this is either in the borehole (“downhole”) near the injection zone and/or at the wellhead.

Gauges can be monitored manually through digital or analog displays, or electronically through wireless or wired communications to a computer or recording device. The gauges should be monitored on a regular basis; some gauges, particularly in sensitive areas, may need to be monitored continuously with an automated system. The gauge reading should be properly recorded and documented in accordance with the site injection operations procedures.

As with other components of the injection system, flow meters need to be compatible with the CO₂ and able to handle the anticipated flows and pressures documented in the injection plan. Orifice meters, turbine meters, and Coriolis meters are examples of devices that can be calibrated for CO₂, and provide adequate accuracy for flow measurement. Typically, an injection permit will include some requirements regarding the frequency at which calibration should take place and the accompanying data that needs to be reported to the regulator.

Injection rates and schedules can be controlled from the source (be it a tanker or a storage facility) through control valves or automated control systems. If the CO₂ is being supplied during pilot testing by a third party, it is recommended to have the supplier present during the startup of the injection process as they may be able to provide equipment and recommendations throughout the initial stages of the injection test.

CO₂ Leak Alarms

In addition to the operations monitoring described above, worker safety may necessitate the installation of sensors that monitor the concentration of CO₂ in the atmosphere near pipes, valves, compressors, and storage tanks that contain CO₂. These sensors are intended to sound alarms if any set points are reached (e.g., levels of pressure, temperature, vibration) to alert the operator in the event of a hardware leak.

If a problem occurs during the injection operation, employees need to be alerted immediately so corrective measures can be initiated. The alarms can include lights, audio, text messages, and e-mail notifications, and can be triggered using either an automated control system or a manual system.

Collection Ports

Collection ports could be installed to collect fluid samples whenever and wherever necessary. Small formation fluid samples are commonly used to get in-situ information on contaminants, tracers, dissolved solids, etc. The sample ports may include a valve mechanism that can be opened slowly so that a representative sample can be safely obtained. Ports may be installed at several points of interest to collect a small sample for analysis.

Support Buildings

The number, size, and configuration of support buildings, if necessary, would vary based on the size and type of operation. There are several reasons for having support building. For example, a field site could have a support building(s) to provide office space for the operations personnel. The buildings offer a degree of working comfort and safety for personnel by reducing exposure to weather conditions and noise. Support buildings are sometimes used to protect the injection equipment, particularly electronics and sensitive equipment, from the weather. Support buildings are also used to reduce potential noise issues. One of the MRCSP Phase II project sites used two buildings—one to house the compressors, and the other to house the blower, glycol regeneration unit, and post-compression pump, which protected the equipment from weather damage and reduced the ambient noise levels.

5.3 Additional Considerations

If a project includes ECBM or EOR, the operator will likely need to consider the following elements in the project planning:

5.3.1 Enhanced Coalbed Methane (ECBM)

The surface equipment required for injection of CO₂ into a reservoir for ECBM recovery would be similar in nature to the equipment used for CCS of dry CO₂ in a saline reservoir. However, with ECBM there will be the

production and handling of methane and CO₂, usually collected from an off-set extraction well; once captured, these gases should be separated and compressed. Typical pipeline standards require that methane gas to be purified (a common standard is less than two percent CO₂ or seven pounds CO₂ per thousand cubic feet [mcf]) so the project should check with the pipeline carrier for the applicable standards. The recovered CO₂ is usually utilized for supplemental injection supply. In some cases, coalbed methane reservoirs produce coal fines that are light enough to travel through the piping system. Therefore, filtering of the re-cycled CO₂ stream is a typical practice before re-injection. Sock and cartridge filters can be placed before the reinjection plant as well as before any CO₂ injection pumps. Filters may also be used in other injection projects if aging transmission pipelines carrying CO₂ have corroded, causing rust and other debris to collect in the system.

5.3.2 Enhanced Oil Recovery (EOR) CO₂ Floods

A large portion of EOR CO₂ floods are conducted by injecting water alternated with gas (WAG) to improve sweep efficiency of the flood front in the reservoir. This requires the surface facilities to be designed to handle water in the injection system. The injection profiles for these floods usually proceed with long periods of CO₂ injection followed by a short water injection period to improve the sweep. Some operators therefore use fiberglass surface pipelines to prevent corrosion that could occur when combining water and CO₂ in the same system. In addition, the valves, regulators, sensors, and other equipment necessary to complete the system could use stainless steel trim (internals) and Teflon (PTFE) or nylon seals. The metering equipment is generally constructed of stainless steel tubulars and internal tubing.

Some operators have found that after years of conducting CO₂ injection floods, the injection system can be constructed of carbon steel pipe since the retention time of water in the pipeline system is brief given that dry CO₂ readily dehydrates the pipe, leaving little contact time for corrosion to occur. Corrosion inhibitors can be injected into pipelines and downhole tubulars that create a film to protect the carbon steel surface from corrosion.

5.3.3 Produced Water

During some injection operations or well installation activities, water may be produced. There are several methods to handle and/or dispose of produced water and the operator will need to investigate the method(s) that make the most sense for a specific projects. Some of these approaches are discussed in more detail in **Appendix F**. Ideally, operators may be able to find a beneficial use for produced water. Some of the reuse applications that have been employed by others include the following:

- Reinjection of the treated water to replenish the potable groundwater supply.
- Domestic use.
- Use in EOR applications.
- Industrial use.
- Agricultural use.

If there are no acceptable applications for the beneficial use of produced water, the operator will likely need to find a disposal or treatment options (see **Appendix F** for additional discussion). These might include:

- Discharge under an NPDES permit into approved waterways.
- Underground injection into UIC-approved disposal wells.
- Evaporation from collection ponds; to enhance evaporation, some regulators will allow produced water to be sprayed over collection ponds. The residual material would have to be disposed of or, if allowed, reused.
- Offsite disposal in commercial treatment or disposal facilities.

5.4 Injection

As previously discussed, injection operations are carried out in three stages: Startup Operations, Routine Injections, and Routine Field Operations. From this point forward, the project will move through each of the three aforementioned stages. It is possible, depending on issues encountered during operation, that the project may “digress,” or go back to an earlier stage. Should the situation warrant, a shut-down, restart, or staggered injection schedule may be appropriate.

5.4.1 Startup Operations

Prior to system operation, the system should undergo a startup and shakedown process to ensure that the system operates correctly and within the manufacturer’s specifications. Appropriate field readings would be collected to ensure that initial injection rates are documented. Typically, monitoring and system adjustments during system startup are collected at an increased frequency compared to normal system operation. During these visits, the engineer of record will usually visit the site and perform an inspection of the final connections. Testing, modifications, and adjustments should be completed until the system is operating according to the manufacturer’s and design specifications.

It is usually desirable to have continuity in the operations and a single point of contact. The PCOR Partnership established a single engineer whose sole responsibility was to coordinate with the CO₂ supplier to ensure adherence to the injection schedule and specified conditions to oversee and monitor the offloading of the trucks for their smaller pilot tests. In order to have a smooth operation, it was important for this person to coordinate with all levels of the vendor and supplier chain to avoid delays and maintain smooth injection operations.

Once it is determined the system meets design specifications, the operator would be ready to inject into the storage formation. As the operator injects CO₂ into the borehole, the wellbore begins to pressure up and the operator monitors the operational injection pressure to make certain it does not exceed the permitted pressure. The operational injection pressure is a function of the hydrologic properties of the selected storage reservoir and is monitored closely. If the operational injection pressure exceeded the fracture pressure of the confining unit, the integrity of the reservoir could be compromised. In addition, too much pressure could compromise the

integrity of the well seal. Therefore, if elevated injection pressures are encountered during the injection test, the project typically would re-evaluate the injection formation for storage. The Startup period can last several days, or months depending on the formation conditions (e.g., injectivity), amount of CO₂ being injected, and the number of integrated systems brought online.

5.4.2 Routine Injection

Once a well/system has completed system start up, it is considered to be in the Routine Injection stage, and remains in this stage until close-out. During this stage, continuous CO₂ injection and monitoring of the wells occurs. There are some instances when these wells might need routine maintenance, which will be discussed further in Routine Field Operations.

Carbon dioxide injection procedures may vary depending on the size of the project (pilot or commercial) and the volume to be injected. Most pilot projects depend on CO₂ injection from tanker trucks, while commercial projects typically would receive CO₂ through commercial pipelines. Continuous monitoring of the subsurface, well integrity, produced water, and other factors may be required by regulatory agencies. This section describes the injection parameters, monitoring strategies, reporting, optimization, and O&M procedures typically performed during the injection of CO₂ into a reservoir. Data collected can also be used to confirm that formation and wellhead pressures are behaving as expected by the models.

CO₂ Injection Procedures

During routine injections, the operators typically perform continuous monitoring to ensure injection pressures and rates do not exceed permitted levels.

Proper O&M of the injection system is vital to a successful project. A detailed O&M plan should be prepared in the Pre-Injection Planning activities. The O&M plan should contain diagrams and supplier-specific information for each component, including supplier, part number, specifications, maintenance procedures, and maintenance schedules. The O&M plan should adequately address standard operating procedures for startup, operating mode, normal shutdown and emergency shutdown, and use of operating logs to track equipment performance trends. In addition, safety meetings and formal classes can

be held to properly train personnel on identifying critical process temperatures and pressures and to understand all controls, monitoring systems, and alarms of the injection facility. Safe zones and rally points should be clearly defined and marked in case of an emergency. All health and safety documentation should be maintained onsite within easy access of all personnel.

Monitoring

Monitoring should occur throughout the entire injection process. It is important to have close coordination between monitoring and injection operations, since the type and timing of monitoring measurements can conflict with injection operations. Monitoring is site-specific but could occur in the surface, near-surface, and subsurface; monitoring strategies and approaches are discussed in greater detail in the MVA Manual, which provides a thorough description of the challenges and goals of monitoring at several stages of the process. **Figure 5-5** shows various monitoring techniques that could be implemented during the Routine Injection to monitor CO₂.

Regulatory agencies and permits require regular monitoring of well integrity. Surface monitoring associated with the operation of the system and worker safety may also be required. Other types of surface monitoring unrelated to the injection operations may be required as discussed in the MVA Manual. Finally, various types of subsurface monitoring may be necessary during the injection process, and the reader should consult the MVA Manual for some monitoring objectives and approaches.

5.4.3 Routine Field Operations

Routine field operations include optimization of the CO₂ injection, periodic operational readings, compliance with injection permits, and well integrity evaluations.

Well Field Optimization

Well field optimization involves a series of procedures and strategies to allow the injection system to operate at peak efficiency by maximizing the volume/rate of injected CO₂ into the subsurface. Operating the injection system at peak efficiency includes ensuring maximum system up time and injection rates.

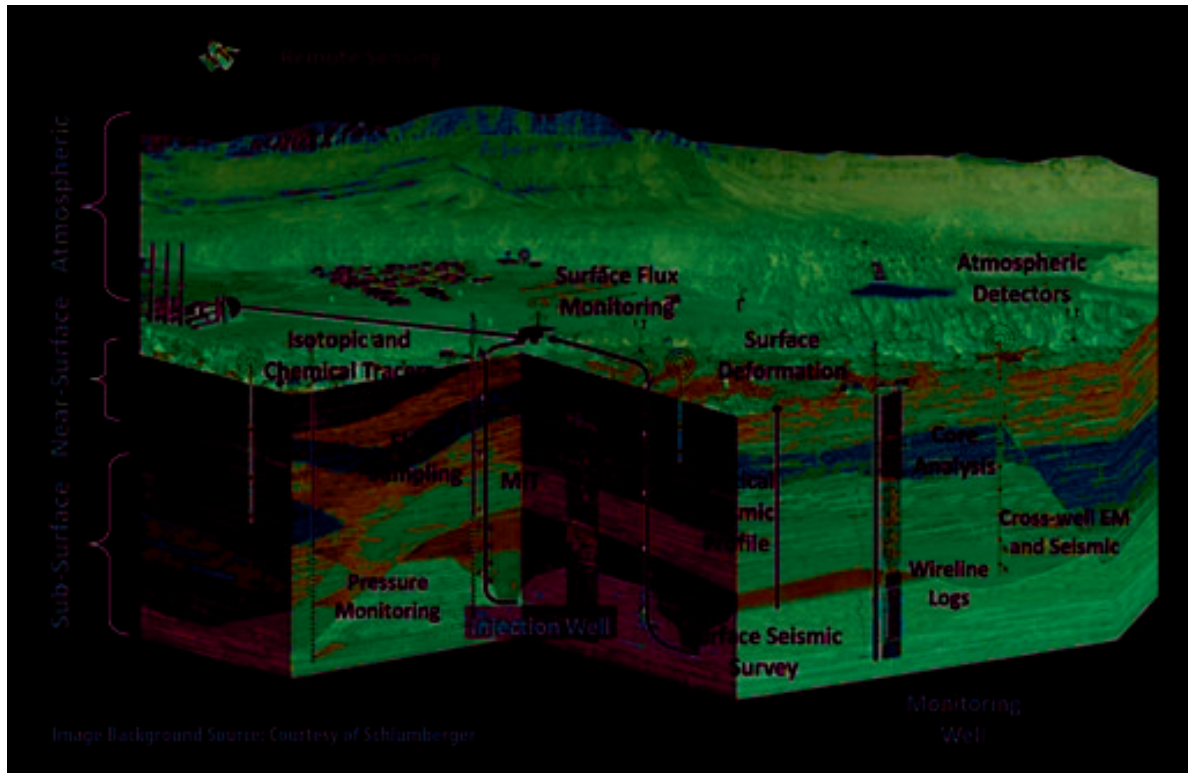

Figure 5-5: Examples of Various Field Monitoring Techniques

For stacked injection intervals with multiple injection zones, field optimization could include balancing the injection stream between both multiple injection wells and injection intervals. This would require that the injection wells be constructed in a manner to allow dividing the injection stream into separate isolated injection intervals. Each individual injection interval would have its own unique porosity, permeability, and injectivity, and the entire injection zone would have an associated confining interval or zone. By knowing the injection rate of CO₂ and the properties of each individual well and/or injection interval, the CO₂ could be diverted into one or more injection zones to maximize the injection rate and minimize the induced pressure on each individual zone. Additionally, wellhead temperature could have an impact on flow rates through pressure-density coupling. Therefore, balancing wellhead pressure and temperature could also help to optimize the system.

Well Integrity

Well integrity could be compromised if injection or formation pressures were to become too high. This could be of particular concern in wells with questionable casing integrity that are being utilized, or if well degradation occurs over time. Well integrity issues may be discovered during geophysical logging and testing of the well, and the detection of such issues does not necessarily result in abandonment of the well. Instead, the oil and gas industry has developed and used several procedures to rectify well integrity issues. For example, a cement squeeze job can be implemented to rectify zonal isolation problems caused by cement integrity issues. Replacing a leaky plug or packer, or installing a second casing string that can be cemented in place to rectify corrosion issues are also options. These same procedures can be used in CO₂ injection projects to remediate injection wells. To begin, the operator should

perform an assessment and determine the type and scope of the potential problem. The result of this assessment will determine the corrective operation to perform at the well. EPA UIC Federal Reporting System Part III: Inspections Mechanical Integrity Testing Form 7520 Section VII specifically requires a documentation of remedial action(s) taken based on MIT failures.

For fractures and leaks, there are several remediation actions. The first is referred to as a cement squeeze¹⁸, and the procedures are performed when cement slurry is injected at the casing depth where well integrity is affected. The cement is forced into potential leakage pathways. Following this procedure, a pressure test can be performed to confirm if well integrity has been achieved. In cases where cement slurries are ineffective, other alternatives could be explored, such as sealing polymers or gels, which have proven to be effective at fixing casing fractures that were otherwise impossible to correct. Self-healing cements have also become available. These cements react with the leaking fluid at the fractures, creating new seals within hours and eliminating the need for further remedial action. Studies have shown that self-healing cements could continue to react throughout the life of the well. Self-expanding cements can also provide better seals if constant pressure changes are expected in the formation. Swell packers have also been inserted within the casing and expanded at the desired depth, thereby acting as an additional seal between the formation and the well.

In some instances, an individual well might need some maintenance because some conditions keep the injection well from operating at optimum injection rates and pressures. In these cases, the well might need to be stimulated, require cleaning, or perforate additional casing sections.

Once a well has reached the end of its active life, the operator might begin a series of activities to close the well. As more wells in a project near the end of their active lives, the operator could begin activities to close down the project or injection field. It is important to recognize that just as Injection Operations ramp up and take place in stages, closure activities gradually increase in intensity and take place in a series of stages. These activities and stages are discussed in the next chapter.

¹⁸ From Schlumberger Oilfield Glossary definition of Cement Squeeze: A remedial cementing operation designed to force cement into leak paths in wellbore tubulars. The required squeeze pressure is achieved by carefully controlling pump pressure. Squeeze cementing operations may be performed to repair poor primary cement jobs, isolate perforations, or repair damaged casing or liner. Found online at: <http://www.glossary.oilfield.slb.com/Display.cfm?Term=cement%20squeeze>.

6.0 Post-Injection Operations

This section describes three main sets of activities that take place after injection ceases: (1) post-injection MVA, (2) well plugging and abandonment, and (3) surface closure. A fourth set of activities, involving well maintenance and potential remediation (or corrective action) if monitoring indicates the need, will also be discussed briefly in this section. **Figure 6-1** illustrates the relationship of these activities which will take place over years, if not decades, after injection ceases while the operator collects the monitoring data necessary to demonstrate that the injected CO₂ will remain permanently stored.

Post-injection activities are related to both specific wells and the entire project. In projects with a small number of wells, post-injection operations for the wells and the overall project may take place simultaneously. In larger projects with many wells, injection will likely cease in some parts of a field as it begins in another. In these cases, post-injection activities may be phased over time.

Once the injection operations are complete, the MVA operations will continue as post-injection MVA. The design of any MVA plan is site-specific. Elements such as monitoring duration, monitoring well locations, and specific equipment should be site-specific and directly related to the risk assessment conducted for the site. MVA consists of various project-specific tests that would

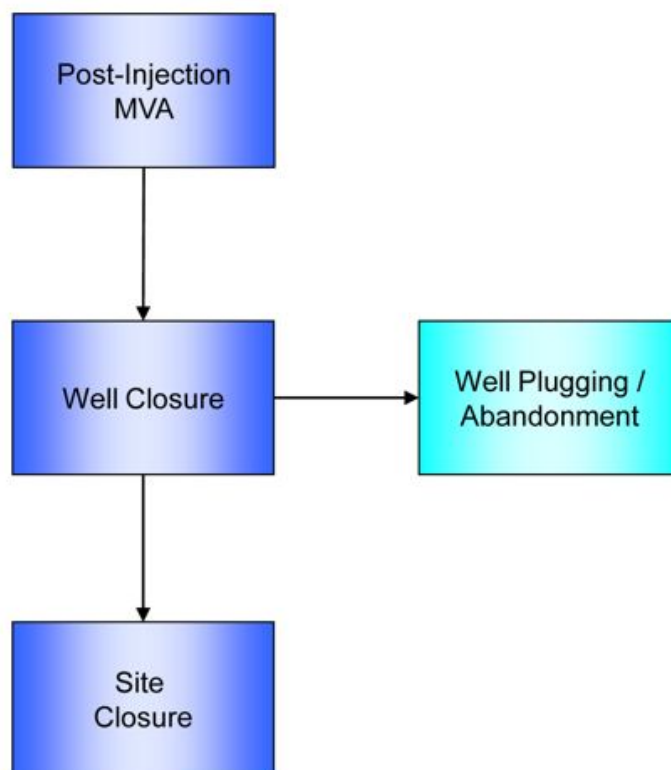

Figure 6-1: Flow Diagram of Post-Injection Operations for a CO₂ Injection Project

be implemented to track the movement and stabilization of the CO₂ plume. The monitoring methods used during the injection would either be continued, discontinued, or replaced with other applicable methods. The post-injection MVA may include continued O&M of the monitoring system and appropriate reporting. Once the post-injection monitoring program has been established, the injection well can be plugged and abandoned, or it can continue to be used as a monitoring point. If the injection wells or any unused monitoring wells are not needed, it is recommended, in accordance with previous plans, Federal, state, and local regulations, that the wells be properly plugged and abandoned. The injection system can be dismantled, except for any MVA equipment that is necessary to support the post-injection MVA program. If possible, the equipment should be removed in such a manner will allow it to be reused. Unusable equipment should be recycled or disposed of properly.

The length of time required for post-injection monitoring will be project-specific, based upon operational data collected during injection, ongoing risk assessments, modeling results, and regulations. **Figure 6-2** illustrates this timeline, showing a CCS project life that spans the entire project, with permitted operations extending

through injection and post-injection to the point where the operator demonstrates that the injected CO₂ plume has stabilized and does not pose a threat to USDWs.

The new EPA UIC Class VI rules require the operator to continue to monitor a CCS project post-injection until they can demonstrate “that the GS project no longer poses an endangerment to USDWs.”¹⁹ The default time period in the rule is 50 years, unless the operator demonstrates that a different time period is sufficient. In order to make this demonstration, the operator needs to consider all computational modeling of the plume and pressure front, the predicted timeframe for pressure decline, the predicted rate of plume migration, the site-specific trapping processes, the results of laboratory analyses and/or field- or site-specific studies, the characterization of the confining zone(s), the quality and extent of all wellbores in the AoR, the location of USDWs in relation to the modeled plume, and any additional site-specific factors required by the regulator. Much of the information, in the form of models, will be developed at the beginning of the project. It may be beneficial to periodically update the models with the operational data, to evaluate the plume stability, prior to making a request from EPA for a reduction in post-operational monitoring.

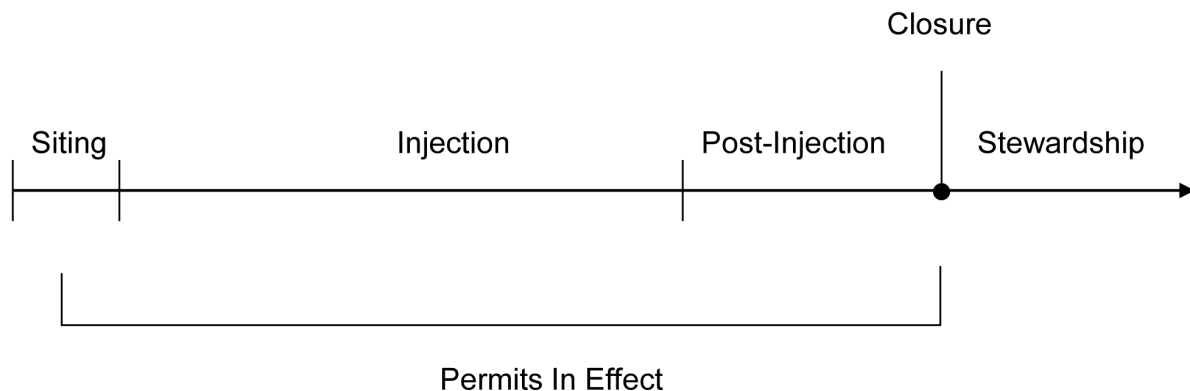

Figure 6-2: Stages in a CCS Project

¹⁹ U.S. EPA 40CFR § 146.93 (b)(2) – Post-injection site care and site closure.

The post-injection MVA will include continued O&M of the monitoring system and appropriate reporting. If a release of CO₂ is detected during the post-injection MVA program, corrective measures may need to be implemented and monitored.

6.1 Post-Injection MVA

During operations, the project operator will use monitoring results to validate, confirm, and update their reservoir simulation. This will serve as the basis for finalizing a post-injection MVA plan (See the MVA Manual [http://www.netl.doe.gov/technologies/carbon_seq/refshelf/MVA_Document.pdf]²⁰) that will likely continue for years after the injection phase. All manufacturer-recommended calibration, cleaning, power source maintenance, and protection measures should be followed to avoid any inaccurate measurements or lapse in the monitoring data. All O&M activities should be documented.

If monitoring results show that the CO₂ movement was as predicted during the injection phase of the project, there will be increased confidence in predictions of the CO₂ movement after injection stops. Conversely, if anomalies are noted during the monitoring period, models and risk assessment(s) may need to be re-evaluated and any corrective measures implemented. For large projects, post-injection default for post-injection MVA has been established for EPA Class VI wells to 50 years, unless site-specific modeling can accurately predict plume stabilization of less than 50 years. Again, for more information, please consult the new EPA UIC Class VI rule as defined by 40CFR Parts 124, 144, 145, 146, and 147.21 It is important to consider and plan, if necessary, for the financial requirements to fund a monitoring program for this length of time. Novel technologies to reduce the long-term operating costs should be explored and a best management practice review should be conducted periodically. For example, using solar panels to power the low-demand monitoring instrumentation can be an effective way to save on energy costs and required infrastructure (Advanced Resources International, Inc., 2010).

The specific monitoring objectives for each project should dictate the monitoring methods and tools used. As previously mentioned, the post-injection MVA plan should be site-specific and designed with the objectives of (1) verifying that the plume is stabilizing and pressures are equilibrating, and (2) detecting potential leakage of the CO₂ before it reaches an identified receptor to allow for early corrective measures. The MVA Manual outlines some of the monitoring methods that can be used to meet such objectives. The MVA Manual describes three monitoring zones, including the atmosphere, the near-surface, and the subsurface. The post-injection MVA will concentrate more on the subsurface monitoring, with some near-surface monitoring. If anomalies are detected, the operator should initiate corrective measures that may range from repairing a well to more extensive remediation in the subsurface.

6.2 Well Closure

Once a well is no longer necessary as part of a CCS project, the operator may choose to take it out of operation. If there is no potential future need for a specific well, the operator might permanently close it by following the well plugging requirements that pertain to the specific well. All wells will have to be plugged before the overall project can be abandoned. However, the operator can also temporarily abandon the wells if there is a chance they may need to be used in the future.

The process of permanently closing wells is commonly referred to as “plugging and abandoning” a well. The well should be plugged and abandoned in accordance with Federal, state, and local regulations (see for instance 40 CFR Part 146.92 for Class VI wells). Prior to plugging the well, the operator will need to notify the appropriate regulatory agencies. Typically the operator will have already filed a well plugging and abandonment plan. These plans should be updated to reflect any new circumstances or conditions requiring a change in the plan. The EPA Class VI UIC regulations specify a number of reporting requirements for the injection facility operator during the various project phases. Once the well is plugged and the site is closed, reports are generally submitted on the procedures and results of each respective process.

²⁰ U.S. DOE/NETL, *Best Practices for: Monitoring, Verification, and Accounting of CO₂ Stored in Deep Geologic Formations*, 2009, First Edition. http://www.netl.doe.gov/technologies/carbon_seq/refshelf/MVA_Document.pdf

²¹ This rule can be found online at U.S. EPA's website: <http://water.epa.gov/type/groundwater/uic/class6/gsregulations.cfm>

6.2.1 Well Plugging and Abandonment Methodologies

Methodologies to properly plug and abandon wells may be found in state-specific guidance documents or regulations. State plugging and abandonment methods may differ based on the region's geology, proximity to aquifers or populated areas, and the construction of the well, among other conditions. If the state provides specific guidelines, they should be followed. If the state does not provide any guidelines for abandonment, the project should consider developing a plan consistent with the best practices from the oil and gas industry and comply with any existing Federal regulations. The following are some basic steps that should be considered during abandonment.

Part of the well plugging process is to remove all obstructions, including the monitoring equipment, from the wells. Monitoring wells that are not installed within the injection zone should have the casing removed, if possible. Due to the construction characteristics of the injection well and the potential to create a pathway for leakage, the casing should be abandoned in place for injection wells.

Any casing perforations or open borehole areas should be grouted from the bottom upward with materials that will properly seal the well or the open borehole. This is done by tremie piping the material to the bottom of the hole. As the hole is filled, the tremie pipe is removed prior to the grout setting up. The filler material should be similar to binding cement used during casing installation, as previously described. Aggregate materials can be used when closing a well and are typically used in conjunction with sealant materials. Aggregate materials would not be appropriate for the complete closure of the well because they would not properly seal the well.

Two common sealants include neat cement and concrete grout. Both include Portland cement, with a relatively small amount of water. However, the concrete grout should include sand in the mixture and granular bentonite, a common additive to grout. The bentonite (approximately five percent) reduces the amount of shrinkage once the cement dries.

There are times where bridge seals may be necessary. This should be avoided if possible; however, if there are significant grout take zones that cannot be bridged by bentonite pellets, a bridge seal may be necessary. The hole is then grouted from the bridge seal upward. The bridge seal should be strong enough to support all of the overlying weight. Bridge seals can include grout baskets, wood plugs, neoprene, pneumatic packers, or mechanical packers. A bridge seal is placed above the problem area (leaving the problem zone an open borehole).

Plugging and Abandoning the MRCSP Well

As part of one of its Validation Phase projects, MRCSP installed a 3,564-foot well in July 2009. This well included an 11 3/4-inch diameter conductor casing set to a depth of 164 feet, an 8 5/8-inch diameter intermediate casing string set to a depth of 900 feet, and a 5 1/2-inch diameter deep casing string set to a depth of 3,564 feet. The well was perforated in three intervals as follows: 3,410 to 3,450 feet; 3,456 to 3,474 feet; and 3,482 to 3,510 feet.

Approximately 1,000 tons of commercial CO₂ was injected into the perforated zones between September 20 and September 25, 2009. Following the test, the well was shut in with the injection tubing and packer in place. The tubing was sealed at the surface with a Texas Iron Works (TIW) valve and a plug. After the project was complete, MRCSP plugged and abandoned the well in accordance with the EPA UIC Class I permit.

The well was opened and allowed to flow water for approximately six hours to release pressure in the well resulting from gasification of CO₂ remaining in the tubing. After allowing the well to depressurize, 20 barrels of 10.1 lb/gallon brine were pumped into the tubing to kill the well. Once the well was controlled, the tubing and packer assembly was removed.

Next, mechanical integrity of the well was confirmed by running a CBL across the entire length of the deep casing string. Plugging entailed filling the deep casing (5 1/2-inch) with Class A cement from total depth (3,564 feet) to approximately three feet below ground surface using a cement retainer method. This method involved setting a cement retainer at a depth of approximately 3,350 feet (60 feet above the perforated zone), pumping cement through the tubing below the retainer plug into the perforated zones, and then pumping cement into the casing to fill the remainder of the well above the retainer plug.

Prior to placing the cement, the deep casing string was cut off approximately 100 feet below ground to allow cement to flow between the 5 1/2-inch and 8 5/8-inch casing strings. The other casing strings were cut off approximately three feet below ground surface and a steel plate was welded to the top of the 8 5/8-inch casing string. The remaining hole was backfilled to the ground surface with soil and a concrete marker, flush with the ground surface, was emplaced above the well. The concrete marker included a brass tag with UIC permit number and other identifying information. See **Figure 6-3** for an illustration of the plugged well.

The well site was restored to pre-operational conditions, which included two major activities: (1) removal of the stone aggregate that was laid down before drilling commenced, replacement of the top soil, and final grading of the site; and (2) reseeding of the site with grass.

Well plugging activities were conducted from March 29 through April 21. Preparing and plugging the well occurred between March 30 and April 1, 2010. After cement was placed in the well, the well sat sealed until April 12, 2010, when the casing was cut off and the steel plate was welded onto the casing. Site restoration activities occurred from April 14-21, 2010.

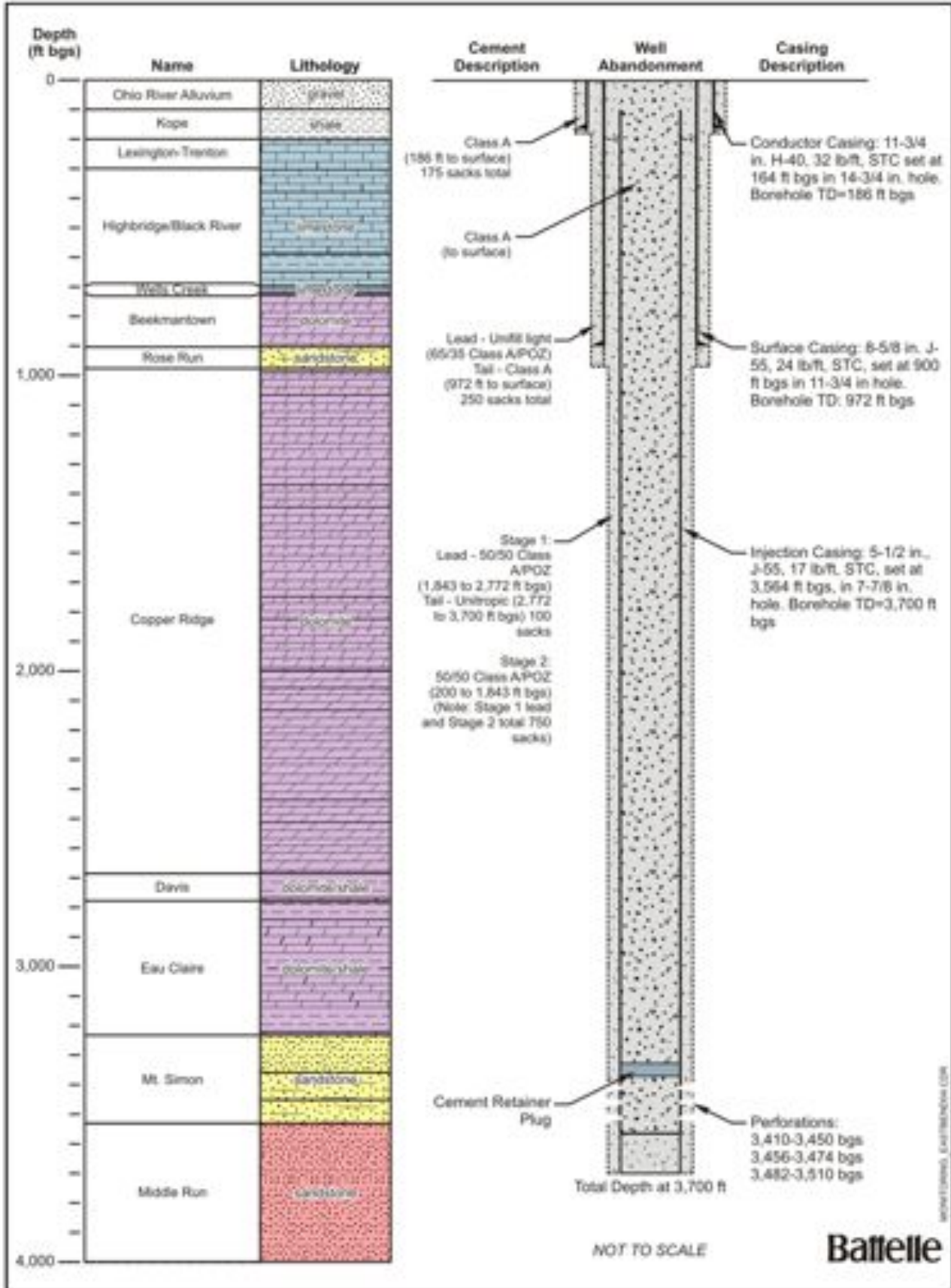

Figure 6-3: Depiction of MRCSP Phase II Test Well Following Plugging and Abandonment

6.3 Site Closure

Once the injection operations are complete, the injection equipment and facilities not required for long-term monitoring should be removed from the site. All trash should be cleaned up and hauled away. The topography should be re-graded and reseeded to the owner's preferences in a manner which still allows for easy access to the monitoring equipment (Advanced Resources International, Inc., 2010).

Monitoring equipment may be reused if it is in properly functioning condition. Prior to re-deploying any sensors or sensor networks, they must be calibrated and tested to confirm their accuracy and reliability. If the sensors appear to be worn and will need to be deployed over an extended period of time, they should be replaced.

7.0 Conclusion

CCS is one of several promising emission-reduction strategies that can be used to help stabilize and reduce CO₂ emissions in the atmosphere while maintaining America's energy independence. The technical underpinning for well-management activities associated carbon storage is found in the more than a century of experience gained in the oil and gas industry. Wells are a critical component of any CCS project; they will be drilled and completed for multiple purposes, including: exploring the suitability of geologic formations, injecting CO₂, monitoring the behavior of injected CO₂, and in some cases of GS through EOR and ECBM.

The purpose of this report is to share lessons learned regarding site development planning, site preparation, drilling and completion, and injection and post-injection operations. The intended audience for this manual includes those involved in the development and implementation of CCS projects, governmental agencies, and other NGOs. This manual builds on the experiences of the RCSPs and acquired knowledge from the petroleum industry and other private industries that have been actively drilling wells for more than 100 years.

A key lesson and common theme reiterated throughout the seven DOE BPMs is that each project site is unique. This means that each CCS project needs to be designed to address specific site characteristics and should involve an integrated team of experts from multiple technical (e.g., scientific and engineering) and nontechnical (e.g., legal, economic, communications) disciplines. Building on lessons learned from the petroleum industry and the RCSPs' efforts to date, this manual is a companion to several other carbon storage evolving best practices documents either recently published or under development within DOE. Subjects for these companion documents include: MVA; simulation and risk assessment; site screening, selection, and initial characterization; geological depositional systems; well construction and closure; regulatory compliance; public outreach and education; and terrestrial sequestration.

Over time, as additional experience is gained from CCS wells, this manual will be updated.

References

- (NETL), N. E. (2009). *Discharge*. Retrieved July 14, 2009, from Produced Water Management Technology Descriptions–Injection for Hydrological Purposes: <http://www.netl.doe.gov/technologies/pwmis/techdesc/injecthyd/index.html>.
- (NETL), National Energy Technology Laboratory. (2009). *Discharge*. Retrieved July 16, 2009, from Produced Water Management Technology Descriptions - Fact Sheet: <http://www.netl.doe.gov/technologies/pwmis/techdesc/discharge/index.html>.
- Advanced Resources International, Inc. (2010). *Pump Canyon CO₂ - ECBM/Sequestration Demonstration, San Juan Basin, New Mexico*. Southwestern Regional Partnership for Carbon Sequestration.
- Advanced Resources International, Inc. (2010). *Plant Daniel Project Closure Report*. The United States Department of Energy - National Energy Technology Laboratory.
- Argonne National Laboratory. (n.d.). *Drilling Waste Management Technology Descriptions*. Retrieved July 2, 2009, from Drilling Waste Management Information System.
- Argonne National Laboratory. (n.d.). *Beneficial Reuse of Drilling Wastes*. Retrieved July 2, 2009, from Drilling Waste Management Information System.
- Argonne National Laboratory. (n.d.). *Bioremediation*. Retrieved July 2, 2009, from Drilling Waste Management Information System: <http://web.ead.anl.gov/dwm/techdesc/biorem/index.cfm>.
- Argonne National Laboratory. (n.d.). *Commercial Disposal Facilities*. Retrieved July 2, 2009, from Drilling Waste Management Information System: <http://web.ead.anl.gov/dwm/techdesc/commercial/index.cfm>.
- Argonne National Laboratory. (n.d.). *Disposal in Salt Caverns*. Retrieved July 2, 2009, from Drilling Waste Management Information System: <http://web.ead.anl.gov/dwm/techdesc/reuse/index.cfm>.
- Argonne National Laboratory. (n.d.). *Drilling Practices That Minimize Generation of Drilling Wastes*. Retrieved July 2, 2009, from Drilling Waste Management Information System: <http://web.ead.anl.gov/dwm/techdesc/drilling/index.cfm>.
- Argonne National Laboratory. (n.d.). *Land Application*. Retrieved July 2, 2009, from Drilling Waste Management Information System: <http://web.ead.anl.gov/dwm/techdesc/land/index.cfm>.
- Argonne National Laboratory. (n.d.). *Onsite Burial (Pits, Landfills)*. Retrieved July 2, 2009, from Drilling Waste Management Information System: <http://web.ead.anl.gov/dwm/techdesc/solid/index.cfm>.
- Argonne National Laboratory. (n.d.). *Slurry Injection of Drilling Wastes*. Retrieved July 2, 2009, from Drilling Waste Management Information System: <http://web.ead.anl.gov/dwm/techdesc/slurry/index.cfm>.
- Argonne National Laboratory. (n.d.). *Solidification and Stabilization*. Retrieved July 2, 2009, from Drilling Waste Management Information System: <http://web.ead.anl.gov/dwm/techdesc/solid/index.cfm>.
- Argonne National Laboratory. (n.d.). *Thermal Treatment Technologies*. Retrieved July 2, 2009, from Drilling Waste Management Information System: <http://web.ead.anl.gov/dwm/techdesc/thermal/index.cfm>.

- Argonne National Laboratory. (n.d.). *Using Muds and Additives with Lower Environmental Impacts*. Retrieved July 2, 2009, from Drilling Waste Management Information System: <http://web.ead.anl.gov/dwm/techdesc/lower/index.cfm>.
- Augustine, C. T. (n.d.). *A comparison of Geothermal with Oil and Gas well Drilling Costs Proceedings Thirty-First Workshop on Geothermal Reservoir Engineering*. Retrieved July 22, 2009, from Stanford University Website: <http://pangea.stanford.edu/ERE/pdf/IGAstandard/SGW/2006/augustin.pdf>.
- Bansal, K. a. (1999). Exploration and Production Operations - Waste Management A Comparative Overview: U.S. and Indonesia Cases". *SPE54345, SPE Asia Pacific Oil and Gas Conference, Jakarta, Indonesia, April 20-22*. Jakarta.
- Battelle. (2009). *Preliminary Hydrogeologic Characterization Results from the Wallula Basalt Pilot Study*. Morgantown: NETL.
- Benson, S. a. (2002, November 18-22). *Monitoring to Ensure Safe and Effective Geologic Storage of Carbon Dioxide*. Retrieved from Intergovernmental Panel on Climate Change (IPCC) Workshop on Carbon Sequestration: <http://arch.rivm.nl/env/int/ipcc/docs/css2002/ccs02-10.pdf>.
- Benson, S. H. (2002). *Lessons Learned from Natural and Industrial Analogues for Storage of Carbon Dioxide in Deep Geologic Formations*. Lawrence Berkeley National Laboratory Report LBNL-51170.
- Boysen, J. J. (1999). The Current Status of Commercial Deployment of the Freeze Thaw Evaporation Treatment of Produced Water. *SPE/EPA 1999 Exploration and Production Environmental Conference, March 1-3*. Austin.
- Brost, D. (2002). Water Quality Monitoring at the Kern River Field. *Ground Water Protection Council Produced Water Conference*. Colorado Springs.
- Carr, T. (2007). *Wellbore Abandonment for Geologic Storage of CO₂*. SAIC consultant.
- Celia, M. B. (2004). Quantitative estimation of CO₂ leakage from GS - analytical models, numerical models, and data needs. *Princeton Environmental Institute, The Princeton papers at Vancouver*, pp. GHGT-7.
- Chalaturnyk, R. (2007). Role of Permanent Downhole Integrated Instrumentation Systems in Assessing Wellbore Performance - Penn West CO₂-EOR Monitoring Project. *IEA Greenhouse Gas R&D Programme (IEA GHG), 3rd Wellbore Integrity Workshop*.
- CNBC. (2009). *Court: Water from gas drilling must be regulated*. Retrieved September 15, 2009, from CNBC website: <http://www.cnbc.com/id/30317483>.
- ConocoPhillips. (2008, December). *Drilling Waste Management Plan*. Retrieved July 6, 2009, from ConocoPhillips Alaska North Slope Colville River Unit: <http://www.conocophilpsalaska.com/permits/CD5%20Permit%20apps%202008/CD5%20Drig%20Waste%20Plan.pdf>.
- Department of Energy (DOE). (1999). *Environmental Benefits of Advanced Oil and Gas Production Technology*. Retrieved from U.S. Department of Energy, Office of Fossil Energy: http://www.osti.gov/bridge/product.biblio.jsp?osti_id=771125.
- Department of Environmental Protection (DEP). (1998). *Roadspreading of Brine for Dust Control and Road Stabilization: Fact Sheet*. Retrieved August 26, 2009, from Commonwealth of Pennsylvania: <http://www.dep.state.pa.us/dep/deputate/minres/oilgas/fs1801.htm>.

- Department of Labor (DOL). (2009, May 20). *Oil and Gas Well Drilling and Service eTool*. Retrieved August 4, 2009, from Occupational Safety & Health Administration: <http://www.osha.gov/sITC/etools/oilandgas/>.
- Department of the Interior and Department of Agriculture (DOI and DOA). (2007). *Surface Operating Standards and Guidelines for Oil and Gas Exploration and Development*. Retrieved September 16, 2007, from Bureau of Land Management (BLM): http://www.blm.gov/pgdata/etc/medialib/blm/wo/MINERALS_REALY_AND_RESOURCE_PROTECTION_/energy/oil_and_gas.Par.18714.File.dat/OILgas.pdf.
- Duluth Metals, Limited, Encampment Resources L.L.C., and Lehmann Exploration Inc. *Attachment 1: Summaries of Operating Plans for Proposed Exploratory Drilling and Activities*. Franconia: Duluth Metals, Encampment Resources, & Lehman Exploration (Duluth et al.).
- Energy Information Administration (EIA). (2007). *Oil and Gas Lease Equipment and Operating Costs 1988 Through 2006*. Retrieved July 22, 2009, from Energy Information Administration website: http://www.eia.doe.gov/pub/oil_gas/natural_gas/data_publications/cost_indices_equipment_production/current/coststudy.html.
- Energy Information Administration, U.S. Department of Energy. (2007, May). *International Energy Outlook 2007*. Retrieved from Energy Information Administration website: [http://www.eia.doe.gov/oiaf/ieo/pdf/0484\(2007\).pdf](http://www.eia.doe.gov/oiaf/ieo/pdf/0484(2007).pdf).
- Environmental Protection Agency (EPA). (2001). *Class I Underground Injection Control Program: Study of the Risks Associated with Class I Injection Wells*. Environmental Protection Agency.
- Environmental Protection Agency (EPA). (1998). *Determination of the Mechanical Integrity of Injection Wells*. Retrieved from United States Environmental Protection Agency: http://www.epa.gov/region5/water/uic/r5guid/r5_05.htm.
- Environmental Protection Agency (EPA). (2002). *Exemption of Oil and Gas Exploration and Production Wastes from Federal Hazardous Waste Regulations. EPA Office of Solid Waste Document EPA530-K-01-004*. Retrieved July 31, 2009, from The Class V Underground Injection Control Study, Volume 23, Subsidence Control Wells." EPA/816-R-99-014w: http://www.epa.gov/OGWDW/uic/class5/pdf/study_uic-class5_classvstudy_volume23-subsidencecontrol.pdf.
- Environmental Protection Agency (EPA). (2004). *State UIC Programs website*. Retrieved September 16, 2009, from Environmental Protection Agency: <http://permanent.access.gpo.gov/lps21800/www.epa.gov/safewater/uic/primacy.htm>.
- Environmental Protection Agency (EPA). (1999). *The Class V Underground Injection Control Study, Volume 20, Salt Water Intrusion Barrier Wells*. Retrieved September 14, 2009, from Environmental Protection Agency (EPA) website: http://www.epa.gov/ogwdw/uic/class5/dpf/study_uic-class5_classvstudy_volume20-salineintrusionbarrier.pdf.
- Environmental Protection Agency (EPA). (1999). *The Class V Underground Injection Control Study, Volume 23, Subsidence Control wells*. Retrieved September 14, 2009, from Environmental Protection Agency (EPA) website: http://www.epa.gov/ogwdw/uic/class5/pdf/study_uic-class5_classvstudy_volume23-subsidencecontrol.pdf.
- Environmental Protection Agency (EPA). (2009, June 12). *Wetlands Homepage*. Retrieved July 28, 2009, from Environmental Protection Agency: <http://www.epa.gov/owow/wetlands/vital/what.html>.
- Environmental Protection Agency. (2008). *Geologic CO₂ Sequestration Technology and Cost Analysis, Technical Support Document*. EPA 816-B-08-009.
- Environmental Studies Research Funds (ESRF). (2004, March). *Drilling Waste in the Mackenzie Delta (Inuvialuit Settlement Region)*. Retrieved July 6, 2009, from Drilling Waste Management Recommended Best Practices: <http://eps.mcgill.ca/~courses/c550/Environmental-impact-of-drilling/Drilling-waste-in-the-Mackenzi-Delta-Region-REPORT.pdf>.

- Federal Highway Administration (FHWA). (2008). *Freight Management and Operations*. Retrieved September 16, 2009, from U.S. Department of Transportation: http://ops.fhwa.dot.gov/freight/sw/permit_report.htm.
- Federal Register. (2008, July 25). *Part II Environmental Protection Agency, 40 CFR Parts 144 and 146, Federal Requirements Under the Underground Injection Control (UIC) Program for Carbon Dioxide (CO₂) GS(GS) Wells; Proposed Rules*. Retrieved from Federal Register, 2008: <http://edocket.access.gpo.gov/2008/pdf/E8-16626.pdf>.
- Ground Water Protection Council (GWPC). *Injection Wells, An Introduction to Their Use, Operation, and Regulation*. Oklahoma City: GWPC.
- Halliburton. (2010). *Halliburton*. Retrieved 7 13, 2010, from Halliburton, Inc.: www.halliburton.com.
- Heslop, A. (1974). *Gamma-ray log response of shaly sandstones*. McAllen, TX: SPWLA.
- Hill, D. (1993). *Density log errors due to high grade uranium ores*. Oxford: Pergamon Press.
- Hyne, N. (1991). *Dictionary of Petroleum Exploration, Drilling and Production*. Tulsa: PennWell Publishing Company.
- ICF Consulting. (2000). *2000 Overview of Exploration and Production Waste Volumes and Waste Management Practices in the United States*. American Petroleum Institute.
- Interstate Oil and Gas Compact Commission and ALL Consulting (IOGCC and ALL). (2006). *A Guide to Practical Management of Produced Water from Onshore Oil and Gas Operations in the United States*. Retrieved from Interstate Oil and Gas Compact Commission: <http://iogcc.publishpath.com/Websites/iogcc/pdfs/2006-Produced-Water-Guidebook.pdf>.
- Lake, L. (2006). *Petroleum Engineering Handbook and Mitchell, Robert F., Volume II Drilling Engineering*. Society of Petroleum Engineers.
- Land Improvement Contractors of Ontario (LICO). (1999). *Fact Sheet Number 4: "Road Drainage"*. Retrieved August 21, 2009, from Land Improvement Contractors of Ontario: Drainage: <http://www.drainage.org/factsheets/fs4.htm>.
- Lawrence Berkeley National Laboratory (LBNL). (2004). *GEO-SEQ Best Practices Manual, Geologic Carbon Dioxide Sequestration: Site Evaluation to Implementation*. U.S. Department of Energy, Office of Fossil Energy.
- Lewicki, J. B. (2006). *Natural and industrial analogues for release of CO₂ from storage reservoirs: Identification of features, events, and processes and lessons learned*. Lawrence Berkeley National Laboratory.
- Loizzo, M. (2007). Program Manager. *EPA Technical Workshop on Geosequestration: Well Construction and Mechanical Integrity Testing* (p. 8). Albuquerque: U.S. EPA.
- Lyons, w. a. (2005). *Standard Handbook of Petroleum & Natural Gas Engineering*. Burlington: Elsevier, Inc.
- Lyons, W. G. (2001). *Air and Gas Drilling Manual*. New York: McGraw-Hill.
- Lyons, W., & Plisga, G. (2005). *Standard Handbook of Petroleum & Natural Gas Engineering*. Burlington: Elsevier, Inc.
- McMillen, S. R. (2004). Biotreating E&P Wastes: Lessons Learned from 1992-2003. *Seventh International Conference on Health, Safety and Environment in Oil and Gas Exploration and Production Calgary, Alberta, Canada March 29-31*.
- Midwest Geological Sequestration Consortium. (2009). *Enhanced Oil Recovery I: Loudon Single Well Huff 'n' Puff*. Champaign: The University of Illinois.

- Morillon, A. J. (2002). Drilling and Waste Management. *SPE International Conference on Health, Safety, and the Environment in Oil and Gas Exploration and Production, March 20-22*.
- Mussett, A. a. (2000). *Looking Into the Earth: An Introduction to Geological Geophysics*. Cambridge, United Kingdom: Cambridge University Press.
- Myer, L., Beyer, J. H., Collins, D., Trautz, R., Shirley, D., Boyer, J., et al. (2010). *Lessons Learned from Drilling an Exploratory CO₂ Injection Well Near the Cholla Power Plant, Holbrook, AZ*. WESTCARB.
- National Energy Technology Laboratory (NETL). (2009). *Agricultural Use*. Retrieved July 17, 2009, from Produced Water Management Information System: <http://www.netl.doe.gov/technologies/pwmis/techdesc/aguse/index.htm>.
- National Energy Technology Laboratory (NETL). (2007). *Carbon Sequestration Atlas of the United States and Canada*.
- National Energy Technology Laboratory (NETL). (2008). *Carbon Sequestration Atlas of the United States and Canada*. Second Edition.
- National Energy technology Laboratory (NETL). (2009). *Domestic Use*. Retrieved July 17, 2009, from Produced Water Management Descriptions - Fact Sheet: <http://www.netl.doe.gov/technologies/pwmis/techdesc/domuse/index.htm>.
- National Energy Technology Laboratory (NETL). (2009). *Evaporation*. Retrieved July 17, 2009, from Produced Water Management Technology Descriptions - Fact Sheet: <http://www.netl.doe.gov/technologies/pwmis/techdesc/evap/index.htm>.
- National Energy Technology Laboratory (NETL). (2009). *Injection for Hydrological Purposes*. Retrieved July 17, 2009, from Produced Water Management Technology Descriptions - Fact Sheet: <http://www.netl.doe.gov/technologies/pwmis/techdesc/injecthyd/index.htm>.
- National Energy Technology Laboratory (NETL). (2009). *Introduction to Produced water*. Retrieved July 7, 2009, from Produced Water Management Information System: <http://www.netl.doe.gov/technologies/pwmis/intropw/index.html>.
- National Energy Technology Laboratory (NETL). (2009). *Monitoring, Verification, and Accounting of CO₂ Stored in Deep Geologic Formations*.
- National Energy Technology Laboratory (NETL). (2009). *Offsite Commercial Disposal*. Retrieved July 17, 2009, from Produced Water Management Technology Descriptions - Fact Sheet: <http://www.netl.doe.gov/technologies/pwmis/techdes/offsite/index.html>.
- National Energy Technology Laboratory (NETL). (2005). *Oil & Natural gas Environmental Program*. Retrieved July 14, 2009, from Program Produced Water Management: <http://www.netl.doe.gov/technologies/oil-gas/publications/prgmfactsheets/PrgmPrdwtrMgt.pdf>.
- National Energy Technology Laboratory (NETL). (2009). *Underground Injection for Disposal*. Retrieved July 16, 2009, from Produced Water Management Technology Descriptions - Fact Sheet: <http://www.netl.doe.gov/technologies/pwmis/techdesc/injectdisp/index.html>.
- Norman, M. S. (2002). Minimizing Environmental Impacts and Maximizing Hole Stability - the Significance of Drilling with Synthetic Fluids in New Zealand. *New Zealand Petroleum Conference Proceedings, February 24-27*. New Zealand.
- Pacific, M. (2002). *Upper Basalt Geothermal Exploration Project; Plan for Exploration*. Retrieved August 18, 2009, from Mammoth Pacific: <http://mammothpacific.com/pdf/Upper%20Basalt%20POE.pdf>.

- Paillet, F. a. (1982). Acoustic modes of propagation in the borehole and their relationship to rock properties. In *Geophysics* (pp. 1215-1228).
- Pennsylvania Department of Conservation and Natural Resources. (2009). *Assessment of Risk, Legal Issues, and Insurance for Geologic Carbon Sequestration in Pennsylvania*. Harrisburg: PA DCNR.
- Pennsylvania Department of Environmental Protection (PA DEP). (2009). *Orphan Oil and Gas wells and The Orphan Well Plugging Fund; Fact Sheet*. Retrieved September 30, 2009, from PA DEP website: <http://www.elibrary.dep.state.pa.us/dsweb/Get/Document-74405/5500-FS-DEP-1670.pdf>.
- Pruess, K., Tsang, C., Law, D., & Oldenburg, C. (2001). An Intercomparison Study of Simulation Models for Geologic Sequestration of CO₂. *Proceedings: First National Conference on Carbon Sequestration*. Pittsburgh.
- Railroad Commission of Texas (RRC). (2000, January). *Well Plugging Primer*. Retrieved July 22, 2009, from Railroad Commission of Texas state website: <http://www.rcc.state.tx.us/environmental/plugging/plugprimer1.pdf>.
- Reed, W. O. (2007). *Haul Road Dust Control; Fugitive dust characteristics from surface mine haul roads and methods of control*. Retrieved August 26, 2009, from Centers for Disease Control: <http://www.cdc.gov/niosh/mining/pubs/pdfs/hrdcf.pdf>.
- Rider, M. (1990). Gamma-ray log shape used as a facies indicator: Critical analysis of an oversimplified method. In A. L. Hurst, *Geological application of wireline logs* (pp. 27-37). Geological Society of London.
- Riesterberg, D. E., Koperna, G. J., Kuuskraa, V. A., Esposito, R., Harrison, K., Berry, R., et al. (2009). *CO₂ Sequestration Permitting at the SECARB Mississippi Test Site*. San Antonio: Society of Petroleum Engineers.
- Savage, D. M. (2004). A generic FEP database for the assessment of long-term performance and safety of the GS of CO₂ Version 1.0.
- SECARB. (2010). *Final Report: Plant Daniel Project Closure Report, Volume 1 of 2*. Advanced Resources International, Inc / NETL.
- Society of Petroleum Engineers (SPE). *Petroleum Engineering Handbook Volume II: Drilling Engineering*. (L. Lake, & R. Mitchel, Eds.).
- Spears & Associates, Inc. (2004). *Oilfield Report*. Tulsa.
- Stewart, D. (2006). Developing a New Water Resource from Production Water. *13th International Petroleum Environmental Conference, October 23-27*. San Antonio.
- Susich, M. a. (2003). *Onshore Drilling Waste Management: Beneficial Reuse of Cuttings*. Marathon Oil Company. OASIS Environmental, Inc.
- Tans, P. (2008). *Trends in Atmospheric Carbon Dioxide - Mauna Loa*. National Oceanic and Atmospheric Administration, U.S. Department of Commerce.
- Tarton Controls, Inc. (2005). *Tartan Controls, Inc.* Retrieved 7 13, 2010, from Tartan Controls, Inc.: www.tartancontrols.com.
- Texas Carbon Capture and Storage Association (TCCSA). (2009). *EPA Draft Rules for UIC Class VI Wells*.

- Trimeric Corporation. (2010). *MGSC Phase II Coal Bed Methane: CO₂ Injection Equipment Report*. Midwest Geological Sequestration Consortium.
- United Nations Environmental Programme (UNEP). (2008). *Summary of by Country and Territory on the 31st January 2008. World Database on Protected Areas*. Retrieved July 20, 2009, from United Nations Environmental Programme World Database on Protected Areas: http://www.unep-wcmc.org/wdpa/mdgs/WDPAPAsstats_Jan08_download.xls.
- University of Minnesota Extension (UME). (2002). *Managing Water Series #8*. Retrieved August 21, 2009, from Forest Management Practices Factsheet: <http://www.extension.umn.edu/distribution/naturalresources/DD6977.html>.
- Water-Technology. (2009). *Water-Technology*. Retrieved August 25, 2009, from Water-Technology: <http://www.water-technology.net/glossary/culvert.html>
- Wilson, E. a. (2008). *Carbon Capture and Sequestration: Integrating Technology, Monitoring and Regulation*. Cambridge: The MIT Press.
- World Resources Institute. (2008). *CCS Guidelines: "Guidelines for Carbon Dioxide Capture, Transport and Storage"*. Washington, DC: WRI.



Appendix A – Compilation of Key Well Drilling and Construction Information for RCSP Test Sites

Project Name	Partnership	State	UIC Permit Class and Permitting Agency	Additional Permits and Approvals	Type of Sequestration
Sugar Creek Project	MGSC	Kentucky	"Class II, EPA Region 4"	Re-permitted by USEPA Region 5	EOR
Mumford Hills Project	MGSC	Indiana	"Class II, IN Department of Natural Resources"	None	EOR
Loudon Single Well Huff N Puff Project	MGSC	Illinois	None	Considered a well treatment or stimulation; no permit required	HNP
Tanquary Well Project	MGSC	Illinois	"Class II, IL Department of Natural Resources"	None	ECBM
Zama Acid Gas EOR, CO ₂ Storage, and Monitoring Project	PCOR	Alberta, Canada	ERCB Directive 65—Resource Application for Oil and Gas Wells and Directive 51—Injection and Disposal Wells	2 additional approvals to accommodate the injection of impure streams of CO ₂ .	EOR
Lignite CCS Project	PCOR	North Dakota	"Class II, ND Industrial Commission"	N/A	ECBM
NW McGregor EOR HNP Project	PCOR	North Dakota	"Class II, ND Industrial Commission"	N/A	EOR / HNP
Plant Daniel Project	SECARB	Mississippi	"Class V, MS Department of Environmental Quality"	NEPA EQ submitted to DOE August 31, 2006 with categorical exclusion approval received September 28, 2006.	Saline
Black Warrior Project	SECARB	Alabama	"Class II, AL Oil and Gas Board"	NEPA EQ submitted to DOE July 13, 2009 with categorical exclusion approval received August 10, 2009.	ECBM
Gulf Coast Stacked Storage Project	SECARB	Mississippi	"Class II, MS Oil and Gas Board"	NEPA EQ submitted to DOE March 28, 2007 with categorical exclusion approval received May 4, 2007.	EOR
Central Appalachian Basin Coal Test	SECARB	Virginia	"Class II, EPA Region 3"	NEPA EQ submitted to DOE February 11, 2008 with categorical exclusion approval received July 28, 2008.	ECBM
Pump Canyon CO ₂ -ECBM/Sequestration Demonstration	SWP	New Mexico	"Class II, NM Oil Conservation Division"	ROW for Pipeline on BLM and NM State Trust lands. Work Authorization Agreement between SWP and ConocoPhillips	ECBM
SACROC CO ₂ Injection Project	SWP	Texas	"Class II, Railroad Commission of Texas"	N/A	EOR
Aneth EOR Sequestration Test	SWP	Utah	"Class II, UT Department of Natural Resources"	N/A	EOR
Cholla CO ₂ Test Fee 1 Project	WESTCARB	Arizona	"Class II, EPA Region 9"	"Aquifer Protection Permit, AZPDES De Minimus General Permit, 404 General Permit, Air Permit"	CCS
Appalachian Basin Geologic Test at R.E. Burger Power Plant: Fegenco Well	MRCSP	Ohio	"Class V, OH Environmental Protection Agency"	State Oil and Gas Drilling Permit	Saline
Duke Energy - East Bend Well Site	MRCSP	Kentucky	"Class V, EPA Region 4"	State Oil and Gas Drilling Permit	Saline
Michigan Basin Geologic Test	MRCSP	Michigan	"Class V, EPA Region 5"	State Oil and Gas Drilling Permit	Saline
Wallula Basalt Pilot Study	Big Sky	Washington	"Class V, WA Department of Ecology"	State Environmental Policy Act (SEPA) Review, WA Dept. of Ecology	Basalt

Project Name	Partnership	Basin Name	Injection Formation(s) (Reservoir)	Confining Formation(s) (Caprock)	Lithology	Geologic Classification	TVD (ft)	Injection Depth (ft)	Core Intervals
Sugar Creek Project	MGSC	Illinois Basin	Jackson Sandstone	Fraileys Shale	Clastic	Shelf Clastic	No TVD Survey; assumed vertical well	1867–1879	Obtained core analysis from field operator
Mumford Hills Project	MGSC	Illinois Basin	Clore Sandstone	Clore Shale	Clastic	Fluvial Channel	No TVD Survey; assumed vertical well	1905–1925	Obtained core analysis from field operator
Loudon Single Well Huff N Puff Project	MGSC	Illinois Basin	Cypress Sandstone / Mississippi Weiler Sandstone	Cypress Shale	Clastic	Delta Tide Dominated	No TVD Survey; assumed vertical well	1510–1530	Obtained core analysis from field operator
Tanquary Well Project	MGSC	Illinois Basin	Springfield Coal	Dykersburg Shale	Coal	Coal	960	896–902	Core #1: 887–906.5 ft
Zama Acid Gas EOR, CO ₂ Storage, and Monitoring Project	PCOR	Zama Basin	Middle Devonian Keg River Formation	Muskeg Anhydrite	Carbonate (dolomite)	Pinnacle Reef	5020	4878	No core in this well
Lignite CCS Project	PCOR	Williston Basin	Lignite Seams in Ft. Union Formation	Clay/Mud layers within formation	Coal	Coal	1246	1100	Core #1: 1070–1090 ft
NW McGregor EOR HNP Project	PCOR	Williston Basin	Mission Canyon Limestone	Charles Fm Tight Limestone and Anhydrites	Carbonate	Shallow Reef	10,147' TD Plugged to 8,150'	8052	Core #1: 8042–8088 ft
Plant Daniel Project	SECARB	Mississippi Interior Saly Basin	Massive Sand, Lower Tuscaloosa	Marine Tuscaloosa	Clastic	Fluvial Deltaic	9720	8520–8720	Multiple cores at zones of interest (inj., Primary Cap, Secondary Cap, zones)
Black Warrior Project	SECARB	Black Warrior	Pottsville Formation (coal zones)	Pottsville Formation (marine shale units)	Coal	Coal	3510	1000–2500	Multiple cores at monitoring wells
Gulf Coast Stacked Storage Project	SECARB	Mississippi Interior Saly Basin	Tuscaloosa Formation	Upper Tuscaloosa, Eagle Ford Shale, Austin Chalk	Clastic	Fluvial	10500 +	10300–10500	Multiple existing injection wells. Coring intervals in one injection well 10,415 to 10,487 ft
Central Appalachian Basin Coal Test	SECARB	Appalachian	Pocahontas Formation / Lee Formation	Norton Formation	Coal	Coal	2534	1600–1700 (Lee) 2100–2300 (Pocahontas)	Multiple cores in the Lee and Pocahontas Formations
Pump Canyon CO ₂ - ECBM/Sequestration Demonstration	SWP	San Juan Basin	Fruitland Coal Formation	Kirtland Shale	Coal	Coal	3153	~3050	Cores gathered from Kirtland Shale, cuttings gathered from Fruitland
SACROC CO ₂ Injection Project	SWP	Permian Basin	Horseshoe Atoll and Pennsylvanian Reef / Bank Play	Wolfcamp	Carbonate	Limestone from a horseshoe atoll	~6700	~6600	Cores taken from the oil formation (Canyon)
Aneth EOR Sequestration Test	SWP	Paradox Basin	Desert Creek Formation, Ismay Formation	Gothic Shale	Carbonate	Limestone, both oolitic and algal	~5900	~5800	Cores from several wells within 1 to 2 miles from the pilot site. Gothic shale and Desert Creek
Cholla CO ₂ Test Fee 1 Project	WESTCARB	Holbrook Basin	Martin Formation / Naco Formation / Supai Formation	Moenkopi Formation	Clastic / Carbonate / Clastic	Sandstone / Limestone- Mudstone- Dolomite	3853	3500 TD	25 sidewall cores at zones of interest (Supai, Naco, Martin formations and Granite basement formation)
Appalachian Basin Geologic Test at R.E. Burger Power Plant: Fegenco Well	MRCSP	Appalachian	Clinton SS / Salina Fm / Oriskany SS	Ohio Shale	Clastic / Carbonate / Clastic	Shelf Clastic / Shallow Shelf restricted / Shelf Clastic	8384	5000–7500	Multiple cores at zones of interest (inj., Primary Cap, Secondary Cap zones)
Duke Energy - East Bend Well Site	MRCSP	Cincinnati Arch	Mt. Simon	Eau Claire	Sedimentary Layers	Sandstone / Near Shore Marine	3564	3410–3510	Multiple cores at zones of interest
Michigan Basin Geologic Test	MRCSP	Michigan Basin	Bass Islands Dolomite	Antrim Shale	Sedimentary Layers	Sandstone	5800	3400–3500	Core #1: 3030–3090 ft Core #2: 3400–3520 ft Multiple sidewall cores
Wallula Basalt Pilot Study	Big Sky	Columbia River Basin	Interflow zones, Grande Ronde Basalt	"Primary: Slack Canyon basalt interior; Secondary: Umtanum basalt interior"	Basalt Interflow Zones	Saline (Basalt/Mafic)	4110 (Cement plug up to 2910 ft)	2716–2910	Multiple sidewall cores at zones of interest

Project Name	Partnership	Long string Casing Size (inches)	Cement(s) Used	Final Cement Interval(s)	Current Injection Amount (metric tons)	Injection Rate	Injection (Wellhead) Pressure
Sugar Creek Project	MGSC	5.5	N/A existing well used	1480 ft to TD (existing well used; intervals given by operator)	6560	18–27 metric tons/day	1425 psig (regulated maximum)
Mumford Hills Project	MGSC	5.5	N/A existing well used	980 ft to TD (existing well used; intervals given by operator)	6295	23–32 metric tons/day	1500 psi (regulated maximum)
Loudon Single Well Huff N Puff Project	MGSC	6	N/A existing well used	200 ft to TD (existing well used; intervals given by operator)	39	4.5 metric tons/day	500 psig
Tanquary Well Project	MGSC	5.5	API class A cement	TD to surface	91	0.85 metric tons/day	736 psig (regulated maximum)
Zama Acid Gas EOR, CO ₂ Storage, and Monitoring Project	PCOR	7	Class G + 2% CaCl ₂ & 45kg Cello Flakes	650 ft to 4878 ft	90,000 acid gas (60,000 CO ₂)	80 tons/day (total acid gas)	No higher than 1160 psig
Lignite CCS Project	PCOR	7	Class "C" Cement	TD to surface	80	6.5 tons/day	605–770 psig
NW McGregor EOR HNP Project	PCOR	5.5	Not reported (well drilled 1968)	Surface to 600' MD then from at least 7,000' to TD	400	12.2 tons/hr	2800 psig
Plant Daniel Project	SECARB	5.5	Lead: HTLD Tail: Corosochem (pozzolan/latex blend)	TD to surface	2740	170–180 tons/day	1100 psig
Black Warrior Project	SECARB	5.5	Class "A" Cement	3248 ft (base of casing) to surface	252	1250 ton/day max.	544 to 1,025 psi
Gulf Coast Stacked Storage Project	SECARB	5.5	Unknown	Varies, but not complete from TD to surface	627,744	225,000–450,000 tons/year	2900 psi
Central Appalachian Basin Coal Test	SECARB	4.5	Unknown	2370 ft to surface	907	95 tons/day	1000 psia
Pump Canyon CO ₂ - ECBM/Sequestration Demonstration	SWP	5.5	N/A	N/A	16,700	16,700 metric tons in 378 days (initially ~200 metric tons/day to <25 metric tons/day during the last few months)	1040 psi
SACROC CO ₂ Injection Project	SWP	N/A	N/A existing well used	N/A existing well used	157,000	625,000 metric tons/yr into 4 wells surrounding the producer (sim. & prod. data indicate ~50% go into the pattern)	N/A
Aneth EOR Sequestration Test	SWP	N/A	N/A existing well used	N/A existing well used	~292,000	As needed based on EOR production and formation limitations	N/A
Cholla CO ₂ Test Fee 1 Project	WESTCARB	N/A	Mixture of Class "G" cement and Tail Slurry of 50-50 pozmix cement	From TD to surface	None (Initial Tests indicated negligible permeability)	As needed based on EOR production and formation limitations	N/A
Appalachian Basin Geologic Test at R.E. Burger Power Plant: Fegenco Well	MRCSP	4.5	Class "A" Cement	From TD to surface	< 50	Preliminary injection tests revealed insufficient injectivity	Preliminary injection tests revealed insufficient injectivity
Duke Energy - East Bend Well Site	MRCSP	5.5	Class "A" Cement	From TD to 200 ft	907	45 tons/hour	1000–1550 psig
Michigan Basin Geologic Test	MRCSP	5.5	Class "H" Cement	TD to 3538 ft	60,000	400–600 tons/day	2000–2020 psig
Wallula Basalt Pilot Study	Big Sky	7	Portland	2716 ft to surface	None	N/A	N/A



Appendix B – Sample Authority for Expenditure (AFE) Form from Petroleum Industry

Project Title																											
AUTHORIZATION FOR EXPENDITURES - Est Cost DRILLING ONLY																											
In US \$ \$0		Project Type :		BUDGET SCHEDULE NO. __																							
Operator:		Well Name :																									
Contract Area:		Well Type :		AFE #:																							
Contract Area #:		Platform/Tripod :		Date:																							
		Basin :																									
Location _____		Surface Coordinate _____																									
Surface Elev. _____		Elevation _____																									
<table border="1" style="width:100%; border-collapse: collapse;"> <tr><th>PROGRAM</th><th>ACTUAL</th></tr> <tr><td>Spud Date</td><td></td></tr> <tr><td>Compl Date</td><td></td></tr> <tr><td>In Service</td><td></td></tr> <tr><td>Drilling Days</td><td></td></tr> </table>		PROGRAM	ACTUAL	Spud Date		Compl Date		In Service		Drilling Days		<table border="1" style="width:100%; border-collapse: collapse;"> <tr><th>PROGRAM</th><th>ACTUAL</th></tr> <tr><td>Rig Days</td><td>0</td></tr> <tr><td>Total Depth</td><td>0</td></tr> <tr><td>Well Cost \$/FL</td><td></td></tr> <tr><td>Well Cost \$/Day</td><td></td></tr> </table>		PROGRAM	ACTUAL	Rig Days	0	Total Depth	0	Well Cost \$/FL		Well Cost \$/Day					
PROGRAM	ACTUAL																										
Spud Date																											
Compl Date																											
In Service																											
Drilling Days																											
PROGRAM	ACTUAL																										
Rig Days	0																										
Total Depth	0																										
Well Cost \$/FL																											
Well Cost \$/Day																											
Close Out Date: _____		Completion Type: _____		Well Status: _____																							
Description	Dry Hole Budget	Completed Budget	Total Budget	Actual Expenditure	Actual Over/Under	% Over/Under																					
1 TANGIBLE COSTS																											
2 Casing			0		0																						
3 Casing Accessories; Float Equip & Liners			0		0																						
4 Tubing			0		0																						
5 Well Equipment - Surface			0		0																						
6 Well Equipment - Subsurface			0		0																						
7 Other Tangible Costs			0		0																						
8 Contingency			0		0																						
9 Total Tangible Costs	\$0	\$0	\$0	\$0	0																						
10 INTANGIBLE COSTS																											
11 PREPARATION & TERMINATION																											
12 Surveys			0		0																						
13 Location Staking & Positioning			0		0																						
14 Wellsite & Access Road Preparation			0		0																						
15 Service Lines & Communications			0		0																						
16 Water Systems			0		0																						
17 Rigging Up/Rigging Down/ Mob/Demob			0		0																						
19 Total Preparations/MOB	\$0	\$0	\$0	\$0	0																						
20 DRILLING - W/O OPERATIONS																											
21 Contract Rig			0		0																						
22 Drig Rig Crew/Contract Rig Crew/Catering			0		0																						
23 Mud, Chem & Engineering Servs			0		0																						
24 Water			0		0																						
25 Bits, Reamers & Coreheads			0		0																						
26 Equipment Rentals			0		0																						
27 Directional Drig & Surveys			0		0																						
28 Diving Services			0		0																						
29 Casing & Wellhead Installation & Inspection			0		0																						
30 Cement, Cementing & Pump Fees			0		0																						
31 Misc. H2S Services			0		0																						
32 Total Drilling Operations	\$0	\$0	\$0	\$0	0																						
33 FORMATION EVALUATION																											
34 Coring			0		0																						
35 Mud Logging Services			0		0																						
36 Drillstem Tests			0		0																						
37 Open Hole Elec Logging Services			0		0																						
39 Total Formation Evaluation	\$0	\$0	\$0	\$0	0																						
40 COMPLETION																											
41 Casing, Liner, Wellhead & Tubing Installation			0		0																						
42 Cement, Cementing & Pump Fees			0		0																						
43 Cased Hole Elec Logging Services			0		0																						
44 Perforating & Wireline Services			0		0																						
45 Stimulation Treatment			0		0																						
46 Production Tests			0	\$0	0																						
48 Total Completion Costs	\$0	\$0	\$0	\$0	0																						
49 GENERAL																											
50 Supervision			0		0																						
51 Insurance			0		0																						
52 Permits & Fees			0		0																						
53 Marine Rental & Charters			0		0																						
54 Helicopter & Aviation Charges			0		0																						
55 Land Transportation			0		0																						
56 Other Transportation			0		0																						
57 Fuel & Lubricants			0		0																						
58 Camp Facilities			0		0																						
59 Allocated Overhead - Field Office			0		0																						
60 Allocated Overhead - Main Office			0		0																						
61 Allocated Overhead - Overseas			0		0																						
62 Technical Services From Abroad			0		0																						
64 Total General Costs	\$0	\$0	\$0	\$0	0																						
65 TOTAL INTANGIBLE COSTS	\$0	\$0	\$0	\$0	0																						
66 TOTAL TANGIBLE COSTS	\$0	\$0	\$0	\$0	0																						
66 TOTAL WELL COST			\$0	\$0	0																						
67 Timed Phased Expenditures																											
68 -This Year																											
69 -Future Years																											
70 Total																											
Operator		Approved By:				Remarks																					
		Position																									
		Date																									
Operator Approval		Approved By:																									
		Position																									
		Date																									

Appendix C – UIC Program Contact Information by State (Nov. 2011)

Organization	UIC Well Class Primacy	Website	Phone Number
Alabama			
AL Oil and Gas Board	Class II	http://www.ogb.state.al.us/ogb/gw_prot.html	205-247-3575
AL Department of Environmental Management	Class V	http://www.adem.state.al.us/default.cnt	334-270-5655
EPA Region 4		http://www.epa.gov/aboutepa/region4.html	404-562-9345
Alaska			
EPA Region 10	Classes I and V	http://www.epa.gov/aboutepa/region10.html	206-553-1200
AK Oil and Gas Conservation Commission	Class II	http://doa.alaska.gov/ogc/	907-279-1433
Arizona			
EPA Region 9	Classes I, II, and V	http://www.epa.gov/aboutepa/region9.html	415-947-8000
Arkansas			
AR Oil and Gas Commission	Class II and V (bromine related)	http://www.aogc.state.ar.us/	501-683-5814
AR Department of Environmental Quality	Class I and V	http://www.adeq.state.ar.us/	501-682-0629
EPA Region 6	Classes I, II, and V when in Tribal Lands	http://www.epa.gov/aboutepa/region6.html	800-887-6063
California			
EPA Region 9	Classes I and V	http://www.epa.gov/aboutepa/region9.html	415-947-8000
CA Department of Conservation	Class II	http://www.conservation.ca.gov/Index/Pages/Index.aspx	916-323-1777
Colorado			
EPA Region 8	Classes I and V (incl. Class II in Tribal Lands)	http://www.epa.gov/aboutepa/region8.html	303-312-6312
CO Oil and Gas Conservation Commission	Class II	http://cogcc.state.co.us	303-894-2100
Connecticut			
CT Department of Environmental Protection	Classes I, II, and V except when in Tribal Lands	http://www.ct.gov/dep/site/default.asp	860-424-3018
EPA Region 1	Classes I, II, and V when in Tribal Lands	http://www.epa.gov/aboutepa/region1.html	617-918-1111
Delaware			
DE Department of Natural Resources and Env. Control	Classes I, II, and V	http://www.dnrec.delaware.gov/Pages/Portal.aspx	302-739-9948
EPA Region 3		http://www.epa.gov/aboutepa/region3.html	215-814-5000
District of Columbia			
EPA Region 3	Classes I, II, and V	http://www.epa.gov/aboutepa/region3.html	215-814-5000
Florida			
EPA Region 4	Class II	http://www.epa.gov/aboutepa/region4.html	404-562-9345
FL Department of Environmental Protection	Classes I and V	http://www.dep.state.fl.us/	850-245-8336

Organization	UIC Well Class Primacy	Website	Phone Number
Georgia			
GA Department of Natural Resources	Classes I, II, and V	http://www.gadnr.org/	404-675-6232
EPA Region 4		http://www.epa.gov/aboutepa/region4.html	404-562-9345
Hawaii			
EPA Region 9	Classes I, II, and V	http://www.epa.gov/aboutepa/region9.html	415-947-8000
Idaho			
EPA Region 10		http://www.epa.gov/aboutepa/region10.html	206-553-1200
ID Department of Water Resources	Classes I, II, and V	http://www.idwr.idaho.gov/	208-287-4800
Illinois			
EPA Region 5		http://www.epa.gov/aboutepa/region5.html	312-353-2000
IL Environmental Protection Agency	Classes I and V	http://www.epa.state.il.us/	217-782-3397
IL Department of Natural Resources	Class II	http://www.dnr.illinois.gov/Pages/default.aspx	217-782-6302
Indiana			
IN Department of Natural Resources	Class II	http://www.in.gov/dnr/	317-232-4200
EPA Region 5	Classes I, II, and V (incl. Class II in Tribal Lands)	http://www.epa.gov/aboutepa/region5.html	312-353-2000
Iowa			
EPA Region 7	Classes I, II, and V	http://www.epa.gov/aboutepa/region7.html	913-551-7003
Kansas			
EPA Region 7	Classes I, II, and V when in Tribal Lands	http://www.epa.gov/aboutepa/region7.html	913-551-7003
KS Department of Health and Environment	Classes I and V	http://www.kdheks.gov/uic/index.html	785-296-5554
KS Corporation Commission	Class II	http://www.kcc.state.ks.us/	316-337-6197
Kentucky			
EPA Region 4	Classes I, II, and V	http://www.epa.gov/aboutepa/region4.html	404-562-9345
Louisiana			
LA Department of Natural Resources	Classes I, II, and V	http://dnr.louisiana.gov/	225-342-5515
EPA Region 6	Classes I, II, and V when in Tribal Lands	http://www.epa.gov/aboutepa/region6.html	800-887-6063
Maine			
ME Department of Environmental Protection	Classes I, II, and V	http://www.maine.gov/dep/	207-287-7688
EPA Region 1		http://www.epa.gov/aboutepa/region1.html	617-918-1111

Organization	UIC Well Class Primacy	Website	Phone Number
Maryland			
MD Department of the Environment	Classes I, II, and V	http://www.mde.state.md.us/Pages/Home.aspx	410-537-3000
EPA Region 3		http://www.epa.gov/aboutepa/region3.html	215-814-5000
Massachusetts			
MA Department of Environmental Protection	Classes I, II, and V	http://www.mass.gov/dep/	617-292-5859
EPA Region 1		http://www.epa.gov/aboutepa/region1.html	617-918-1111
Michigan			
EPA Region 5	Classes I, II, and V	http://www.epa.gov/aboutepa/region5.html	312-353-2000
Minnesota			
EPA Region 5	Classes I, II, and V	http://www.epa.gov/aboutepa/region5.html	312-353-2000
Mississippi			
MS Department of Environmental Quality	Class I and V Wells	http://www.deq.state.ms.us/	601-961-5171
MS Oil and Gas Board	Class II Wells	http://www.ogb.state.ms.us/	601-576-4900
EPA Region 4	Classes I, II, and V when in Tribal Lands	http://www.epa.gov/aboutepa/region4.html	404-562-9345
Missouri			
EPA Region 7	Classes I, II, and V when in Tribal Lands	http://www.epa.gov/aboutepa/region7.html	913-551-7003
MO Department of Natural Resources	Classes I, II, and V	http://dnr.mo.gov/env/wpp/index.html	573-751-1300
Montana			
EPA Region 8	Classes I and V (incl. Class II in most Tribal Lands)	http://www.epa.gov/aboutepa/region8.html	303-312-6312
MO Board of Oil and Gas Conservation	Class II	http://bogc.dnrc.state.mt.us	406-656-0040
MO Fort Peck Office of Environmental Protection	Class II Wells within Fort Peck Tribal Contract Area	http://www.fortpeckoep.org/	406-768-5155
Nebraska			
EPA Region 7	Classes I, II, and V when in Tribal Lands	http://www.epa.gov/aboutepa/region7.html	913-551-7003
NE Oil and Gas Conservation Commission	Class II	http://www.nogcc.ne.gov/	308-254-6919
NE Department of Environmental Quality	Classes I and V wells	http://www.deq.state.ne.us/	402-471-2186
Nevada			
EPA Region 9	Classes I, II, and V when in Tribal Lands	http://www.epa.gov/aboutepa/region9.html	415-947-8000
NV Division of Environmental Protection	Classes I, II, and V	http://ndep.nv.gov/	775-687-4670

Organization	UIC Well Class Primacy	Website	Phone Number
New Hampshire			
NH Department of Environmental Services	Classes I, II, and V	http://des.nh.gov/	603-271-3503
EPA Region 1		http://www.epa.gov/aboutepa/region1.html	617-918-1111
New Jersey			
EPA Region 2	Classes I, II, and V when in Tribal Lands	http://www.epa.gov/aboutepa/region2.html	877-251-4575
NJ Department of Environmental Protection	Classes I, II, and V	http://www.state.nj.us/dep/	609-633-7021
New Mexico			
NM Oil Conservation Division	Oil and Gas Related Injection Wells	http://www.emnrd.state.nm.us/ocd/	505-476-3460
NM Environment Department	All Other Injection Wells	http://www.nmenv.state.nm.us/	505-827-2855
EPA Region 6	Classes I, II, and V when in Tribal Lands	http://www.epa.gov/aboutepa/region6.html	800-887-6063
New York			
EPA Region 2	Classes I, II, and V	http://www.epa.gov/aboutepa/region2.html	877-251-4575
North Carolina			
NC Department of Environment and Natural Resources	Class V	http://portal.ncdenr.org/web/guest	919-715-3060
EPA Region 4		http://www.epa.gov/aboutepa/region4.html	404-562-9345
North Dakota			
EPA Region 8	Classes II and V when in Tribal Lands	http://www.epa.gov/aboutepa/region8.html	303-312-6312
ND Department of Health	Classes I and V	http://www.ndhealth.gov/wq/gw/gw.htm	701-328-5213
ND Industrial Commission	Class II	https://www.dmr.nd.gov/oilgas/	701-328-8020
Ohio			
EPA Region 5	Classes I, II, and V when in Tribal Lands	http://www.epa.gov/aboutepa/region5.html	312-353-2000
OH Environmental Protection Agency	Classes I and V (in partnership w/ OH DNR)	http://www.epa.state.oh.us/	614-644-3020
OH Department of Natural Resources	Class II	http://www.ohiodnr.com/	614-265-6610
Oklahoma			
OK Corporation Commission	Oil and Gas Related Injection Wells	http://www.occ.state.ok.us/	405-521-2211
OK Department of Environmental Quality	All Other Injection Wells	http://www.deq.state.ok.us/	405-702-0100
EPA Region 6	Classes I, II, and V when in Tribal Lands	http://www.epa.gov/aboutepa/region6.html	800-887-6063

Organization	UIC Well Class Primacy	Website	Phone Number
Oregon			
EPA Region 10		http://www.epa.gov/aboutepa/region10.html	206-553-1200
OR Department of Environmental Quality	Classes I, II, and V	http://www.oregon.gov/DEQ/	503-229-5696
Pennsylvania			
EPA Region 3	Classes I, II, and V	http://www.epa.gov/aboutepa/region3.html	215-814-5000
Rhode Island			
RI Department of Environmental Management	Classes I, II, and V	http://www.dem.ri.gov/	401-222-6800
EPA Region 1		http://www.epa.gov/aboutepa/region1.html	617-918-1111
South Carolina			
SC Department of Health and Environmental Control	Classes II and V (State prohibits Class I wells)	http://www.scdhec.gov/	803-898-4300
EPA Region 4		http://www.epa.gov/aboutepa/region4.html	404-562-9345
South Dakota			
EPA Region 8	Classes I and V (incl. Class II in Tribal Lands)	http://www.epa.gov/aboutepa/region8.html	303-312-6312
SD Department of Environment and Natural Resources	Class II	http://denr.sd.gov/des/gw/UIC/UIC.aspx	605-773-4589
Tennessee			
EPA Region 4	Class II	http://www.epa.gov/aboutepa/region4.html	404-562-9345
Department of Environment & Conservation	Classes I and V	http://www.tn.gov/environment/permits/injetwel.shtml	615-532-0109
Texas			
Railroad Commission of Texas	Oil and Gas Related Injection Wells	http://www.rrc.state.tx.us/	877-228-5740
TX Commission on Environmental Quality	All Other Injection Wells	http://www.tceq.state.tx.us/	512-239-1000
EPA Region 6	Classes I, II, and V when in Tribal Lands	http://www.epa.gov/aboutepa/region6.html	800-887-6063
Utah			
EPA Region 8	Classes II and V when in Tribal Lands	http://www.epa.gov/aboutepa/region8.html	303-312-6312
UT Department of Environmental Quality	Classes I and V	http://www.waterquality.utah.gov	801-536-4352
UT Department of Natural Resources	Class II	http://dogm.nr.state.ut.us	801-538-5338

Organization	UIC Well Class Primacy	Website	Phone Number
Vermont			
VT Department of Environmental Conservation	Classes I, II, and V	http://www.anr.state.vt.us/dec/dec.htm	802-241-3800
EPA Region 1		http://www.epa.gov/aboutepa/region1.html	617-918-1111
Virginia			
EPA Region 3	Classes I, II, and V	http://www.epa.gov/aboutepa/region3.html	215-814-5000
Washington			
EPA Region 10		http://www.epa.gov/aboutepa/region10.html	206-553-1200
WA Department of Ecology	Classes I, II, and V	http://www.ecy.wa.gov/ecyhome.html	360-407-6143
West Virginia			
WV Division of Environmental Protection	Classes II and V	http://www.dep.wv.gov/Pages/default.aspx	304-926-0499
EPA Region 3		http://www.epa.gov/aboutepa/region3.html	215-814-5000
Wisconsin			
WI Department of Natural Resources	Classes I, II, and V	http://dnr.wi.gov/	888-936-7463
Wyoming			
EPA Region 8	Class II and V when in Tribal Lands	http://www.epa.gov/aboutepa/region8.html	303-312-6312
WY Oil and Gas Conservation Commission	Class II	http://wogcc.state.wy.us	307-234-7147
WY Department of Environmental Quality	Class I and V	http://deq.state.wy.us/	307-777-7937
UIC Class VI Wells			
UIC Class VI Well regulations were finalized in December 2010. EPA and state authorities are currently in the process of evaluating primacy responsibilities for the newly finalized well class. As of November 2011, all Class VI applications being submitted to the state will be sent to and evaluated by the regional EPA authorities.			

Appendix D – Oil and Gas Contact Information by State (Nov. 2011)

Organization	Purpose	Website	Phone Number
Alabama			
AL State Oil and Gas Board - Tuscaloosa	Drilling Permits and Mineral Rights	http://www.gsa.state.al.us/ogb/ogb.html	205-349-2852
AL State Oil and Gas Board - Mobile	Regional Office	http://www.gsa.state.al.us/ogb/ogb.html	251-438-4848
US DOI Bureau of Land Management - Eastern States	Leasing of Federal Lands	http://www.blm.gov/es/st/en.html	703-440-1600
Alaska			
AK DNR Division of Oil and Gas	State Land Leasing, Resource Evaluation, & Geophysical Exploration Permits	http://dog.dnr.alaska.gov/	907-269-8800
AK Oil and Gas Conservation Commission	Drilling Permit	http://doa.alaska.gov/ogc/	907-279-1433
US DOI Bureau of Land Management AK	Leasing of Federal Lands	http://www.blm.gov/ak/st/en.html	907-271-5960
Arizona			
AZ Oil and Gas Conservation Commission	Drilling and Exploration Permit	http://www.azogcc.az.gov/	520-770-3500
AZ State Land Department	State Land and Mineral Rights	http://www.land.state.az.us/	602-542-4621
US DOI Bureau of Land Management AZ	Leasing of Federal Lands	http://www.blm.gov/az/st/en.html	602-417-9200
Arkansas			
AR Oil and Gas Commission	Drilling and Exploration Permit, Land Leasing	http://www.aogc.state.ar.us/	501-683-5814
AR Geological Survey	Mining and Mineral Resources & Oil and Gas/Fossil Fuel Resources	http://www.geology.ar.gov/home/index.htm	501-296-1877
US DOI Bureau of Land Management - Eastern States	Leasing of Federal Lands	http://www.blm.gov/es/st/en.html	703-440-1600
California			
CA Dept. of Conservation, Division of OGGR	Drilling Permits	http://www.conservation.ca.gov/dog/Pages/Index.aspx	916-323-1777
US DOI Bureau of Land Management CA	Federal Land and Resources Mgmt.	http://www.blm.gov/ca/st/en.html	916-978-4400
Colorado			
CO DNR Oil and Gas Conservation Commission	Drilling Permits & Oil and Gas Location Assessment	http://cogcc.state.co.us/	303-894-2100
US DOI Bureau of Land Management CO	Leasing of Federal Lands	http://www.blm.gov/co/st/en.html	303-239-3600

Organization	Purpose	Website	Phone Number
Connecticut			
CT Department of Environmental Protection	Drilling Permits	http://www.ct.gov/dep/site/default.asp	860-424-3000
US DOI Bureau of Land Management - Eastern States	Leasing of Federal Lands	http://www.blm.gov/es/st/en.html	703-440-1600
Delaware			
DE Department of Natural Resources and Env. Control	Drilling Permits	http://www.dnrec.delaware.gov/Pages/Portal.aspx	302-739-9000
District of Columbia			
US DOI Bureau of Land Management - Eastern States	Leasing of Federal Lands	http://www.blm.gov/es/st/en.html	703-440-1600
Florida			
FL Department of Environmental Protection - Oil and Gas	Drilling Permits	http://www.dep.state.fl.us/water/mines/oil_gas/index.htm	850-488-8217
FL Department of Environmental Protection - State Lands	Leasing of State Lands	http://www.dep.state.fl.us/mainpage/programs/lands.htm	850-245-2555
US DOI Bureau of Land Management - Eastern States	Leasing of Federal Lands	http://www.blm.gov/es/st/en.html	703-440-1600
Georgia			
GA Department of Natural Resources		http://www.gadnr.org/	404-656-3500
US DOI Bureau of Land Management - Eastern States	Leasing of Federal Lands	http://www.blm.gov/es/st/en.html	703-440-1600
Hawaii			
HI Department of Land and Natural Resources - Land Division		http://hawaii.gov/dlnr/land/	808-587-0433
Idaho			
ID Department of Lands	Land/ Mineral Rights for Oil & Gas Exploration	http://www.idl.idaho.gov/	208-334-0200
ID Department of Water Resources	Drilling Permits	http://www.idwr.idaho.gov/	208-287-4800
US DOI Bureau of Land Management ID	Leasing of Federal Lands	http://www.blm.gov/id/st/en.html	208-373-4000
Illinois			
IL Department of Natural Resources - Oil and Gas Division	Drilling Permits	http://dnr.state.il.us/mines/dog/	217-782-6302
US DOI Bureau of Land Management - Eastern States	Leasing of Federal Lands	http://www.blm.gov/es/st/en.html	703-440-1600

Organization	Purpose	Website	Phone Number
Indiana			
IN Department of Natural Resources - Division of Oil and Gas	Drilling Permits & State Land/ Mineral Lease Rights	http://www.in.gov/dnr/dnroil/	317-232-4055
US DOI Bureau of Land Management - Eastern States	Leasing of Federal Lands	http://www.blm.gov/es/st/en.html	703-440-1600
Iowa			
IA DNR Geological and Water Survey	Drilling Permits & State Land/ Mineral Lease Rights	http://www.igsb.uiowa.edu/	319-335-1575
US DOI Bureau of Land Management - Eastern States	Leasing of Federal Lands	http://www.blm.gov/es/st/en.html	703-440-1600
Kansas			
KS Corporation Commission - Oil and Gas Conservation Div.	Drilling Permits & State Land/ Mineral Lease Rights	http://www.kcc.state.ks.us/conservation/index.htm	316-337-6200
US DOI Bureau of Land Management NM/OK/TX/KS	Leasing of Federal Lands	http://www.blm.gov/nm/st/en.html	505-954-2000
Kentucky			
KY EEC Division of Oil and Gas	Drilling Permits & State Land/ Mineral Lease Rights	http://oilandgas.ky.gov/Pages/Welcome.aspx	502-573-0147
US DOI Bureau of Land Management - Eastern States	Leasing of Federal Lands	http://www.blm.gov/es/st/en.html	703-440-1600
Louisiana			
LA Department of Natural Resources - Oil and Gas Division		http://dnr.louisiana.gov/	225-342-4500
US DOI Bureau of Land Management - Eastern States	Leasing of Federal Lands	http://www.blm.gov/es/st/en.html	703-440-1600
Maine			
ME Department of Environmental Protection		http://www.maine.gov/dep/	207-287-7688
US DOI Bureau of Land Management - Eastern States	Leasing of Federal Lands	http://www.blm.gov/es/st/en.html	703-440-1600
Maryland			
MD Department of the Environment		http://www.mde.state.md.us/Pages/Home.aspx	410-537-3000
US DOI Bureau of Land Management - Eastern States	Leasing of Federal Lands	http://www.blm.gov/es/st/en.html	703-440-1600

Organization	Purpose	Website	Phone Number
Massachusetts			
MA Department of Environmental Protection		http://www.mass.gov/dep/	617-292-5500
US DOI Bureau of Land Management - Eastern States	Leasing of Federal Lands	http://www.blm.gov/es/st/en.html	703-440-1600
Michigan			
MI Dept. of Natural Resources and Environment - Env. Quality	Land and Mineral Rights, Drilling Permits, & Office of Geological Survey	http://www.michigan.gov/deq	517-373-7917
US DOI Bureau of Land Management - Eastern States	Leasing of Federal Lands	http://www.blm.gov/es/st/en.html	703-440-1600
Minnesota			
MN DNR - Division of Minerals	Land and Mineral Rights	http://www.dnr.state.mn.us/lands_minerals/index.html	651-259-5959
US DOI Bureau of Land Management - Eastern States	Leasing of Federal Lands	http://www.blm.gov/es/st/en.html	703-440-1600
Mississippi			
MS State Oil and Gas Board	Well Records & Drilling Permits	http://www.ogb.state.ms.us/	601-576-4900
US DOI Bureau of Land Management - Eastern States	Leasing of Federal Lands	http://www.blm.gov/es/st/en.html	703-440-1600
Missouri			
MO DNR Division of Energy	Drilling Permits	http://www.dnr.mo.gov/energy/	573-751-3443
MO DNR Division of Environmental Quality	Quality Conservation	http://www.dnr.mo.gov/env/index.html	573-751-0763
MO DNR Division of Geology and Land Survey	Land and Mineral Rights	http://www.dnr.mo.gov/geology/index.html	573-368-2100
Montana			
MT Board of Oil and Gas Conservation	Drilling Permit Processing	http://bogc.dnrc.mt.gov/	406-656-0040
MT DNR Trust Land Managements Division	Leasing of Mineral Rights	http://dnrc.mt.gov/trust/default.asp	406-444-2074
US DOI Bureau of Land Management MT/ND/SD	Leasing of Federal Lands	http://www.blm.gov/mt/st/en.html	406-896-5000
Nebraska			
NE Oil and Gas Conservation Commission	Drilling Permits & State Land/ Mineral Lease Rights	http://www.nogcc.ne.gov/	308-254-6919
Nevada			
NV Commission on Mineral Resources - Div. of Minerals	Drilling Permits and Mineral Rights	http://minerals.state.nv.us/	775-684-7040
US DOI Bureau of Land Management NV	Leasing of Federal Lands	http://www.blm.gov/nv/st/en.html	775-861-6400

Organization	Purpose	Website	Phone Number
New Hampshire			
US DOI Bureau of Land Management - Eastern States	Leasing of Federal Lands	http://www.blm.gov/es/st/en.html	703-440-1600
New Jersey			
NJ Department of Env. Protection - Div. of Water Supply	Drilling Permits	http://www.nj.gov/dep/watersupply/	609-777-3373
US DOI Bureau of Land Management - Eastern States	Leasing of Federal Lands	http://www.blm.gov/es/st/en.html	703-440-1600
New Mexico			
NM Energy, Minerals and Natural Resources Dept. - Oil & Gas	Drilling Permits	http://www.emnrd.state.nm.us/ocd/	505-476-3460
NM State Land Office - Oil, Gas, and Minerals Division	Land and Mineral Rights	http://www.nmstatelands.org/Overview_6.aspx	505-827-5760
US DOI Bureau of Land Management NM/OK/TX/KS	Leasing of Federal Lands	http://www.blm.gov/nm/st/en.html	505-954-2000
New York			
NY Department of Environmental Conservation	Drilling Permits & Leasing of State Land	http://www.dec.ny.gov/	518-402-8056
US DOI Bureau of Land Management - Eastern States	Leasing of Federal Lands	http://www.blm.gov/es/st/en.html	703-440-1600
North Carolina			
NC Department of Environment and Natural Resources		http://portal.ncdenr.org/web/guest	877-623-6748
US DOI Bureau of Land Management - Eastern States	Leasing of Federal Lands	http://www.blm.gov/es/st/en.html	703-440-1600
North Dakota			
ND State Land Department - Minerals Management Division	Leasing and Mineral Rights	http://www.land.nd.gov/minerals/minerals.htm	701-328-2800
ND Industrial Commission - Oil and Gas Division	Drilling Permits	https://www.dmr.nd.gov/oilgas/	701-328-8020
US DOI Bureau of Land Management MT/ND/SD	Leasing of Federal Lands	http://www.blm.gov/mt/st/en.html	406-896-5000
Ohio			
OH Department of Natural Resources	Drilling Permits	http://www.ohiodnr.com/	614-265-6610
US DOI Bureau of Land Management - Eastern States	Leasing of Federal Lands	http://www.blm.gov/es/st/en.html	703-440-1600

Organization	Purpose	Website	Phone Number
Oklahoma			
OK Corporation Commission	Drilling Permits	http://www.occ.state.ok.us/	405-522-2211
US DOI Bureau of Land Management NM/OK/TX/KS	Leasing of Federal Lands	http://www.blm.gov/nm/st/en.html	505-954-2000
Oregon			
OR Dept. of Geology and Mineral Industries	Drilling Permits & Mineral Land Regulation	http://www.oregongeology.org/sub/default.htm	971-673-1555
US DOI Bureau of Land Management OR/WA	Leasing of Federal Lands	http://www.blm.gov/or/st/en.html	503-808-6002
Pennsylvania			
PA Department of Environmental Protection, Oil & Gas Management	Drilling Permits and State/Land Leasing	http://www.dep.state.pa.us/dep/deputate/minres/oilgas/oilgas.htm	717-772-2199
US DOI Bureau of Land Management - Eastern States	Leasing of Federal Lands	http://www.blm.gov/es/st/en.html	703-440-1600
Rhode Island			
RI Department of Environmental Management		http://www.dem.ri.gov/	401-222-6800
US DOI Bureau of Land Management - Eastern States	Leasing of Federal Lands	http://www.blm.gov/es/st/en.html	703-440-1600
South Carolina			
SC Department of Health and Environmental Control	Drilling Permits	http://www.scdhec.gov/	803-898-3432
US DOI Bureau of Land Management - Eastern States	Leasing of Federal Lands	http://www.blm.gov/es/st/en.html	703-440-1600
South Dakota			
SD Department of Environment and Natural Resources	Drilling Permits	http://denr.sd.gov/	605-773-3151
US DOI Bureau of Land Management MT/ND/SD	Leasing of Federal Lands	http://www.blm.gov/mt/st/en.html	406-896-5000
Tennessee			
TN Dept. of Env. & Conservation - Div. of Water Control	Drilling Permits	http://www.tn.gov/environment/wpc/	615-532-0625
Tennessee Oil and Gas Board		http://www.tn.gov/environment/boards/og/	615-532-0998
US DOI Bureau of Land Management - Eastern States	Leasing of Federal Lands	http://www.blm.gov/es/st/en.html	703-440-1600

Organization	Purpose	Website	Phone Number
Texas			
Railroad Commission of Texas	Drilling Permits and State Land Leasing	http://www.rrc.state.tx.us/	877-228-5740
US DOI Bureau of Land Management NM/OK/TX/KS	Leasing of Federal Lands	http://www.blm.gov/nm/st/en.html	505-954-2000
Utah			
UT DNR Division of Oil, Gas, and Mining - Oil & Gas Program	Drilling Permits	http://oilgas.ogm.utah.gov/	801-538-5340
US DOI Bureau of Land Management UT	Leasing of Federal Lands	http://www.blm.gov/ut/st/en.html	801-539-4001
Vermont			
VT Dept. of Env. Conservation - Agency of Natural Resources	Permit Coordination	http://www.anr.state.vt.us/dec/dec.htm	802-241-3808
US DOI Bureau of Land Management - Eastern States	Leasing of Federal Lands	http://www.blm.gov/es/st/en.html	703-440-1600
Virginia			
VA Dept. of Mines, Minerals, and Energy - Division of Gas & Oil	Drilling Permits	http://www.dmme.virginia.gov/divisiongasoil.shtml	276-415-9700
US DOI Bureau of Land Management - Eastern States	Leasing of Federal Lands	http://www.blm.gov/es/st/en.html	703-440-1600
Washington			
WA DNR Division of Geology and Earth Resources	Drilling Permits and State/Land Leasing	http://www.dnr.wa.gov/Publications/ger_division_fact_sheet.pdf	360-902-1450
US DOI Bureau of Land Management OR/WA	Leasing of Federal Lands	http://www.blm.gov/or/st/en.html	503-808-6002
West Virginia			
WV Dept. of Environmental Protection - Office of Oil & Gas	Drilling Permits	http://www.dep.wv.gov/oil-and-gas/Pages/default.aspx	304-926-0499
US DOI Bureau of Land Management - Eastern States	Leasing of Federal Lands	http://www.blm.gov/es/st/en.html	703-440-1600
Wisconsin			
WI Department of Natural Resources	Drilling Permits	http://dnr.wi.gov/	888-936-7463
US DOI Bureau of Land Management - Eastern States	Leasing of Federal Lands	http://www.blm.gov/es/st/en.html	703-440-1600

Organization	Purpose	Website	Phone Number
Wyoming			
WY Oil and Gas Conservation Commission	Drilling Permits	http://wogcc.state.wy.us/	307-234-7147
U.S. DOI Bureau of Land Management WY	Leasing of Federal Lands	http://www.blm.gov/wy/st/en.html	307-775-6256
Offshore U.S. Territories and Natural Resources Jurisdiction			
Within State Jurisdiction			
Region	Entity	Distance from Shore	Standard miles from Shore
Texas	Railroad Commission of Texas	9 nautical miles (3 marine leagues)	10.36
Florida Gulf Coast	FL Department of Environmental Protection	9 nautical miles (3 marine leagues)	10.36
Louisiana	LA Department of Natural Resources	3 imperial nautical miles	3.45
Other U.S. Coastal States	Respective State Organizations	3 nautical miles	3.45
Beyond State Jurisdiction			
Entity	Distance of Jurisdiction		Phone Number
DOI - Bureau of Ocean Energy Management, Regulation and Enforcement - Minerals Management Service	<p>The seaward limit is defined as the farthest of 200 nautical miles seaward of the baseline from which the breadth of the territorial sea is measured or, if the continental shelf can be shown to exceed 200 nautical miles, a distance not greater than a line 100 nautical miles from the 2,500-meter isobath or a line 350 nautical miles from the baseline.</p> <p>Outer Continental Shelf limits greater than 200 nautical miles but less than either the 2,500 meter isobath plus 100 nautical miles or 350 nautical miles are defined by a line 60 nautical miles seaward of the foot of the continental slope or by a line seaward of the foot of the continental slope connecting points where the sediment thickness divided by the distance to the foot of the slope equals 0.01, whichever is farthest.</p>		202-208-3985

Appendix E – References for Different Aspects of Well Drilling and Construction

Sources	Document / Series Title	Description	Subject
Occupational Health and Safety Administration (OSHA)	SIC 131	Safety Requirements specific to Crude Petroleum and Natural Gas Activities	Safety
	SIC 138	Safety Requirements specific to Oil and Gas Field Services	Safety
	29 CFR 1910	General Industrial Safety and Emergency Standards	Safety
American National Standards Institute (ANSI)/American Society of Safety Engineers (ASSE)	Z41	Personal Protection - Protective Footwear	Safety
	Z49.1	Safety in Welding and Cutting and Allied Processes	Safety
	Z87.1	Practice for Occupational and Educational Eye and Face Protection	Safety
	Z88.2	Respiratory Protection	Safety
	Z89.1	Requirements for Industrial Head Protection	Safety
	Z117.1	Safety Requirements for Confined Spaces	Safety
	Z359.1	Safety Requirements for Personal Fall Arrest Systems, Subsystems and Components	Safety
U.S. Research and Special Programs Administration (RSPA)	49 CFR 171	General Information, Regulations, and Definitions	Safety
	49 CFR 172	Hazardous Materials Table, Special Provisions, hazardous Materials Communications, Emergency Response Information and Training Requirements	Safety
	49 CFR 173	Shippers -- General Requirements for Shipments and Packagings	Safety
	49 CFR 177	Carriage by Public Highway	Safety
	49 CFR 178	Specifications for Packagings	Safety

Sources	Document / Series Title	Description	Subject
American Petroleum Institute (API)	Exploration and Production Publications	Standards including Oilfield Equipment and Material Standards, Offshore Structures, Valves and Wellhead Equipment, Drilling Equipment, Oil Well Cements, Production Equipments, Drilling Fluid Materials, Offshore Safety and Anti-Pollution, etc.	Equipment
	Exploration and Production Publications	Standards including Oilfield Equipment and Material Standards, Offshore Structures, Valves and Wellhead Equipment, Drilling Equipment, Oil Well Cements, Production Equipments, Drilling Fluid Materials, Offshore Safety and Anti-Pollution, etc.	Equipment
	Health and Environmental Issues Publications	Standards for Plant Emissions during Construction, Exploration and Production, Marketing, Transportation, etc. Pollution Prevention and Air/Soil/Water Testing and Research	Equipment / Construction
	Pipeline Publications	Standards on Pipeline Transportation, Installation, Welding, Maintenance, and Third Party Connectivity	Equipment / Construction
	Safety and Fire Protection Publications	Standards for Safety and Fireproofing for Oil and Gas Locations	Equipment / Safety
	Valve Publications	Standards for Wellhead Equipment Installation, Testing, Maintenance, and Replacement	Equipment
International Association of Drilling Contractors (IADC)	IADC Drilling Manual	Recommended Industry Practices	Drilling / Equipment
	Drilling Technology Series	Covering the many aspects of Drilling	Drilling / Equipment
	Formulas and Calculations for Drilling, Production and Workover		Drilling
	High Pressure High Temperature (HPHT) Wells		Drilling
	Introduction to Well Control		Drilling
	Offshore Fire Prevention		Drilling
	Oil and Gas Exploration & Production		Drilling
	Principles of Drilling Fluid Control		Drilling
IADC Guideline for MODUs	Guidelines for Mobile Offshore Drilling Units	Drilling	

Sources	Document / Series Title	Description	Subject
Society of Petroleum Engineers (SPE)	Drilling and Completion Publications	Papers covering horizontal and directional drilling, drilling fluids, bit technology, sand control, perforating, cementing, well control, completions, and drilling operations	Drilling
	Economics and Management Publications	Covers resource and reserve evaluation, portfolio and asset management, project valuation, strategic decision-making and processes, uncertainty/risk assessment and mitigation, systems modeling and forecasting, etc.	Construction
	Production and Operations Publications	Papers on production operations, artificial lift, downhole equipment, formation damage control, multiphase flow, workovers, and stimulation	Construction
	Projects, Facilities & Construction Publications	Covers all aspects of onshore and offshore surface facilities design, project management, operations, and abandonment, including subsea, fixed and floating production systems; pipelines; mid-stream natural gas (LNG, CNG, GTL plants, terminals and transportation); carbon capture and storage; project valuation; integrated asset modeling; remote monitoring and control; safety, human factors and environmental management.	Construction
Further Publications	Well Cementing	By Erik B. Nelson, Schlumberger Educational Services, 5000 Gulf Freeway, Houston, Texas 77023 (1990)	Drilling/ Construction
	Petroleum Well Construction	By Economides, Michael J., Watters, Larry T. and Dunn-Norman, Shari, John Wiley & Sons, West Sussex, England (1998)	Construction
	Applied Drilling Engineering – SPE Textbook Series Volume 2	Bourgoyne, A.T., Millheim, Keith K., Chenevert, Martin E. and Young, Farrile S., Society of Petroleum Engineers, Richardson, Texas (1986)	Drilling

Appendix F – Produced Water Disposal Options

Introduction

Water is used and produced during the drilling and hydraulic fracturing process. This water typically has high salinity and has traces of various materials, particularly metals. There are a variety of management methods for this water that include treatment and reuse, treatment and discharge, or disposal. Treatment and beneficial reuse of the water is a preferred method to preserve natural resources, but may not be the most economic method. Any added costs for this would have to be considered in the overall design of the project. Any beneficial reuse or discharge of produced water would have to be monitored to ensure that no materials are present to potentially impact human health and the ecological environment. Liability concerns and public concerns can be reduced by having clear documentation of the treated water quality.

Treatment and Discharge

There are a variety of treatment options for the produced water, with new technologies being developed (particularly in the oil and gas industry). Once the water has been treated, it can be discharged to surface water bodies, but will require an NPDES permit. Depending on the receiving waters, there may be additional limitations and restrictions, especially in ecologically sensitive and protected waters.

Beneficial Reuse

In order to preserve our greatest natural resource, it is important to find economic and practical beneficial reuses of produced water. There are a variety of potential beneficial uses, some of which are presented below. The applicability of any beneficial use will be dependent on several factors, including:

- Location of the project.
- Distance from the beneficial use location.
- Limitations of the beneficial use.
- Need for the beneficial use.
- Potential regulations for the beneficial use.
- Applicability of the beneficial use.

The potential beneficial uses listed below cannot be viewed as a “cookie cutter” answer to dealing with produced water. Detailed analysis and planning will be required to see what fits the project limitations and project needs. Some examples of beneficial reuse applications include:

- Reinjection of the treated water to replenish the potable groundwater supply.
- Domestic use.
- Use in EOR applications.
- Industrial use.
- Agricultural use.

Reinjection Into Groundwater Supply – A potential shortcut of the hydrogeologic cycle is to inject the treated water directly into the shallow groundwater supply. This not only replenishes the groundwater, but also can provide a significant filtration and storage area for the future groundwater use. Prior to utilizing this method, significant planning would have to be done. Some issues that would have to be addressed include:

- Federal, state, and local regulations.
- Evaluation of the cost to treat the water to drinking water standards.
- Having a clear understanding of the hydrogeologic characteristics of the aquifer injection zone, such as porosity, permeability, transmissivity, geochemical characteristics, and storage potential.
- Understanding of the effect on groundwater gradients and groundwater flow directions.

This method may also be more beneficial for enhancing stream flows during low-flow periods. Instead of direct discharge into the streams under NPDES limitation, the water, once injected into the shallow groundwater supply, would get the benefit of natural filtration through the subsurface and taking on the geochemical nature of the natural environment prior to discharge in surface water bodies.

Domestic Use – Areas of the country have been impacted by a reduced amount of rainfall, which has caused a drop in the groundwater table. Not only does this affect the volume of water that is available for potable domestic uses, it has also been attributed to ground subsidence

issues, which have caused significant structural damage. As the water is removed from the shallow aquifer, the pore space that was once occupied by water and held open by the hydrostatic pressure collapses and resettles. If the water table is significantly dropped through groundwater removal, the surface could also settle significantly. This is mostly restricted to unconsolidated sediments, but could also be significant in karst areas that have shallow saturated caverns. Once the water is removed from the caverns, sudden collapse could occur since the hydrostatic pressure has been removed.

By treating and utilizing the water for domestic use, the need for groundwater extraction could be reduced or averted and has the potential for reducing settlement or collapse, allowing the groundwater tables to stabilize. Even in areas of the county where there are not settlement issues, water may be short of supply or is extracted from surface water bodies. Use of this treated water could assist in meeting the demand for potable water and to reduce the need for surface water extraction.

Enhanced Oil Recovery – The produced water could be used for EOR, as is common in the oil industry. The water is pumped into the source reservoir and used essentially as a flushing agent for removal of the remaining oil. The objective is to displace the oil with the water, resulting in the oil being removed and the water remaining in the reservoir. Water that is removed through this process can be recycled or would have to be treated.

Industrial Use – Some industries require large amounts of water, either from groundwater supplies or from surface water supplies. Industries may be able to utilize the water with limited or no treatment. Once the water is used, industries typically have treatment systems or permits for ultimate discharge.

Agricultural Use – For the reasons listed under the domestic and industrial use, a potential viable use of the treated produced water would be for agricultural use. The geochemical nature of the water would have to be monitored to ensure that it would not damage the crops and would be safe for plant uptake.

Disposal of Produced Water

There are times when the economics or logistics for beneficial use will not work out for a project and the produced water will have to be disposed. There are currently several options, and others may arise as technologies develop.

Discharge – Produced water that cannot be recycled or reused may be discharged under an NPDES permit, assuming that it meets all of the Federal, state, and local regulations. If the storage reservoir is an old oil or gas field, there may be restrictions on the discharge of the produced water.

Underground Injection for Disposal – If there are limitations to discharging the water, and treatment and reuse are not an option, injection of the produced water may be an option. However, this is an unlikely choice for CCS projects, since it adds a competitive nature for the subsurface storage space. If a subsurface storage reservoir is discovered that is not suitable for CCS, then injection of the produced water might be an option. Most produced water that is currently injected in the oil and gas industry is for EOR or under EPA Class II well regulations. The EPA Class VI regulations will govern the storage of CO₂ and the disposition of produced waters as a result of those efforts.

Evaporation – A cost-effective method of disposal, particularly in drier climates, is evaporation of the water. This requires large surface areas to be effective so that the evaporation rate is higher than the inflow rates. Evaporation can be enhanced by spraying the water over an evaporation pond and also by making sure that the accumulated sediments are removed regularly. The sediments, or evaporate material, would have to be disposed of, or a beneficial use would have to be found.

Offsite Commercial Disposal – Most oil and gas companies treat the water at the wellhead, if possible. This water can be reused or discharged; however, the water could be shipped to a central or commercial treatment and disposal facility. This could be done through truck or pipeline transport. If this option is selected, it is important to understand the limitations of the receiving facility and where else they are receiving materials to prevent future liability issues. Environmental infractions of the disposal facility could revert back to the source, which is difficult to determine in litigation.

Contacts

If you have any questions or comments, or would like more information about DOE's Carbon Storage Program, please contact the following individuals:

John Litynski, PE

Technology Manager, Sequestration Division
Office of Coal and Power R&D
412-386-4922
john.litynski@netl.doe.gov

Traci D. Rodosta, PG

Director, Sequestration Division
Strategic Center for Coal
304-285-1345
traci.rodosta@netl.doe.gov

Brian W. Dressel, PG

Project Manager/Focal Lead, Sequestration Division
Strategic Center for Coal
412-386-7313
brian.dressel@netl.doe.gov

More information on DOE's Carbon Storage Program is available at:

http://www.netl.doe.gov/technologies/carbon_seq/index.html.

Acknowledgments

The authors wish to acknowledge the excellent guidance, contributions, and cooperation of the NETL staff, particularly: NETL Technical Monitors John Litynski, Traci Rodosta, and Brian Dressel.

This report presents materials prepared by representatives from the Regional Carbon Sequestration Partnerships.

Lead authors/reviewers include the following:

Big Sky Carbon Sequestration Partnership—*Lee Spangler and Wayne Rowe*

Midwest Geologic Sequestration Consortium—*Rob Finley*

Midwest Regional Carbon Sequestration Partnership—*David Ball, Matt Place, and Sarah Wade*

Plains CO₂ Reduction Partnership—*Ed Steadman and Darren D. Schmidt*

Southeast Regional Carbon Sequestration Partnership—*Ken Nemeth, Gerry Hill, and George Koperna*

Southwest Regional Partnership on Carbon Sequestration—*Brian J. McPherson and Lee Harris*

West Coast Regional Carbon Sequestration Partnership

Leonardo Technologies, Inc. (LTI)

AJW Group—*Sarah Wade*



NATIONAL ENERGY TECHNOLOGY LABORATORY

1450 Queen Avenue SW
Albany, OR 97321-2198
541-967-5892

2175 University Avenue South,
Suite 201
Fairbanks, AK 99709
907-452-2559

3610 Collins Ferry Road
P.O. Box 880
Morgantown, WV 26507-0880
304-285-4764

626 Cochran Mill Road
P.O. Box 10940
Pittsburgh, PA 15236-0940
412-386-4687

13131 Dairy Ashford,
Suite 225
Sugar Land, TX 77478
281-494-2516

WEBSITE: www.netl.doe.gov

CUSTOMER SERVICE: **1-800-553-7681**



April 2012