

Summer 2012

MANAGING NUCLEAR WASTE

The

BRIDGE

LINKING ENGINEERING AND SOCIETY

**Management of Radioactive Waste:
A Socio-Technical Challenge**

Daniel Metlay, B. John Garrick, and Nigel Mote

**Recommendations by the Blue Ribbon
Commission on America's Nuclear Future:
A Plan for Managing Spent Nuclear Fuel
and High-Level Nuclear Waste**

Albert Carnesale

Storage of Spent Nuclear Fuel

Andrew C. Kadak

**Emerging Regulatory Challenges in the
Management of Spent Nuclear Fuel and
High-Level Radioactive Waste**

James Rubenstone

**Industry's Safety Record and the Blue Ribbon
Recommendations: The Way Ahead for the
Management of Used Nuclear Fuel**

Marvin S. Fertel

**Enhancing the Acceptability and Credibility
of a Repository for Spent Nuclear Fuel**

*Hank C. Jenkins-Smith, Carol L. Silva, Kerry G.
Herron, Sarah R. Trousset, and Rob P. Rechar*

NATIONAL ACADEMY OF ENGINEERING
OF THE NATIONAL ACADEMIES

The mission of the National Academy of Engineering is to advance the well-being of the nation by promoting a vibrant engineering profession and by marshalling the expertise and insights of eminent engineers to provide independent advice to the federal government on matters involving engineering and technology.

The BRIDGE

NATIONAL ACADEMY OF ENGINEERING

Irwin M. Jacobs, *Chair*
Charles M. Vest, *President*
Maxine L. Savitz, *Vice President*
Thomas F. Budinger, *Home Secretary*
Venkatesh Narayanamurti, *Foreign Secretary*
C.D. (Dan) Mote Jr., *Treasurer*

Editor in Chief: Ronald M. Latanision

Managing Editor: Carol R. Arenberg

Production Assistant: Penelope Gibbs

The Bridge (ISSN 0737-6278) is published quarterly by the National Academy of Engineering, 2101 Constitution Avenue, N.W., Washington, DC 20418. Periodicals postage paid at Washington, DC.

Vol. 42, No. 2, Summer 2012

Postmaster: Send address changes to *The Bridge*, 2101 Constitution Avenue, N.W., Washington, DC 20418.

Papers are presented in *The Bridge* on the basis of general interest and timeliness. They reflect the views of the authors and not necessarily the position of the National Academy of Engineering.

The Bridge is printed on recycled paper. ♻️

© 2012 by the National Academy of Sciences. All rights reserved.

A complete copy of *The Bridge* is available in PDF format at <http://www.nae.edu/TheBridge>. Some of the articles in this issue are also available as HTML documents and may contain links to related sources of information, multimedia files, or other content.

The

Volume 42, Number 2 • Summer 2012

BRIDGE

LINKING ENGINEERING AND SOCIETY



Editor's Note

- 3 **Managing Nuclear Waste: Part One of a Two-Part Series on Social Science in the Engineering Enterprise**
Ronald M. Latanision

Features

- 5 **Management of Radioactive Waste: A Socio-Technical Challenge**
Daniel Metlay, B. John Garrick, and Nigel Mote
The siting of a deep-mined geologic repository requires strong bonds of trust between implementers, regulators, and the host community.
- 15 **Recommendations by the Blue Ribbon Commission on America's Nuclear Future: A Plan for Managing Spent Nuclear Fuel and High-Level Nuclear Waste**
Albert Carnesale
According to the president's Blue Ribbon Commission, "We know what we have to do, we know we have to do it, and we even know how to do it."
- 23 **Storage of Spent Nuclear Fuel**
Andrew C. Kadak
Regardless of how long spent fuel is stored, eventually it will have to be moved from reactor sites.
- 32 **Emerging Regulatory Challenges in the Management of Spent Nuclear Fuel and High-Level Radioactive Waste**
James Rubenstone
The Nuclear Regulatory Commission must balance its preparations for policy changes with the safe, secure operation of existing facilities, the availability of resources, and the constraints of current law.
- 40 **Industry's Safety Record and the Blue Ribbon Recommendations: The Way Ahead for the Management of Used Nuclear Fuel**
Marvin S. Fertel
The debate over managing high-level radioactive waste is really about extending proven technology and successful practices.
- 49 **Enhancing the Acceptability and Credibility of a Repository for Spent Nuclear Fuel**
Hank C. Jenkins-Smith, Carol L. Silva, Kerry G. Herron, Sarah R. Trousset, and Rob P. Rechard
Lessons learned from prior experience and social science research can influence public attitudes toward nuclear management facilities.

(continued on next page)

	NAE News and Notes
59	NAE Newsmakers
61	NAE Honors 2012 Prize Winners
61	Charles Stark Draper Prize
62	Acceptance Remarks by Wolfgang Helfrich
63	Bernard M. Gordon Prize
63	Acceptance Remarks by Clive L. Dym
64	Report of the Foreign Secretary
65	NAE Chair, Home Secretary, and Councillors Elected
66	2012 German-American Frontiers of Engineering Symposium Held in Potsdam, Germany
68	4th Indo-American Frontiers of Engineering Symposium Held in Arlington, Virginia
70	The Grainger Foundation Frontiers of Engineering Grants for the Advancement of Interdisciplinary Research
71	NAE Regional Meetings
71	Regional Meeting on Energy and Sustainability
72	Symposium on Government-University-Industry Partnerships in Regional Innovation and Entrepreneurship
74	“Making Value,” an NAE Workshop
74	2nd USA Science and Engineering Expo
75	Ambitious Fundraising Goals for NAE’s 50th Anniversary in 2014
76	New NAE Publications
78	Calendar of Events
78	In Memoriam
80	Publications of Interest

THE NATIONAL ACADEMIES

Advisers to the Nation on Science, Engineering, and Medicine

The **National Academy of Sciences** is a private, nonprofit, self-perpetuating society of distinguished scholars engaged in scientific and engineering research, dedicated to the furtherance of science and technology and to their use for the general welfare. Upon the authority of the charter granted to it by the Congress in 1863, the Academy has a mandate that requires it to advise the federal government on scientific and technical matters. Dr. Ralph J. Cicerone is president of the National Academy of Sciences.

The **National Academy of Engineering** was established in 1964, under the charter of the National Academy of Sciences, as a parallel organization of outstanding engineers. It is autonomous in its administration and in the selection of its members, sharing with the National Academy of Sciences the responsibility for advising the federal government. The National Academy of Engineering also sponsors engineering programs aimed at meeting national needs, encourages education and research, and recognizes the superior achievements of engineers. Charles M. Vest is president of the National Academy of Engineering.

The **Institute of Medicine** was established in 1970 by the National Academy of Sciences to secure the services of eminent members of appropriate professions in the examination of policy matters pertaining to the health of the public. The Institute acts under the responsibility given to the National Academy of Sciences by its congressional charter to be an adviser to the federal government and, upon its own initiative, to identify issues of medical care, research, and education. Dr. Harvey V. Fineberg is president of the Institute of Medicine.

The **National Research Council** was organized by the National Academy of Sciences in 1916 to associate the broad community of science and technology with the Academy’s purposes of furthering knowledge and advising the federal government. Functioning in accordance with general policies determined by the Academy, the Council has become the principal operating agency of both the National Academy of Sciences and the National Academy of Engineering in providing services to the government, the public, and the scientific and engineering communities. The Council is administered jointly by both Academies and the Institute of Medicine. Dr. Ralph J. Cicerone and Charles M. Vest are chair and vice chair, respectively, of the National Research Council.

Editor's Note



Ronald M. Latanision

Managing Nuclear Waste: Part One of a Two-Part Series on Social Science in the Engineering Enterprise

The United States derives a significant fraction of its electric power from nuclear power plants (NPPs). One hundred four operating NPPs at 67 sites generate about 20 percent of this nation's electricity. However, nuclear electric generation also produces wastes (used fuel and other kinds of waste). Although we have been operating NPPs for more than 50 years, the management of those wastes is still a vexing issue at the convergence of technology, public policy, and social science. This issue of *The Bridge* addresses issues related to nuclear electric generation in general and nuclear waste management in particular.

The short-term approach to handling nuclear wastes has been to store them in spent fuel pools or in dry storage containers or casks at reactor sites, an approach that has been adopted throughout the world. In the longer term, there appears to be universal agreement that the most appropriate method of managing commercial and defense-related wastes is by emplacing them in a deep geologic repository for up to one million years, thereby protecting the public from the release of radionuclides that could have adverse effects on human health and the environment.

The United States was well along a path toward building such a repository at Yucca Mountain in Nevada, a state that has no NPPs within its borders. Over the years, opposition to the selection of the Yucca Mountain site has grown, both on the part of the public and of their elected representatives.

In 2009, the Obama Administration decided to pursue termination of the project. Nevertheless, the reality remains that we must take seriously our need as a nation to manage the wastes we produce, whether they be municipal wastes or wastes related to electric generation or manufacturing, with a view toward their potential impact on the environment. The need to protect our air and water from contamination should be a national imperative.

In January 2010, the White House directed Secretary of Energy Steven Chu to establish a Blue Ribbon Commission on America's Nuclear Future (the BRC). In January 2012, the BRC, led by co-chairs Lee Hamilton and Brent Scowcroft, released its final report. Since then, Secretary Chu has appointed a Working Group to provide advice to the U.S. Department of Energy on implementing the policy recommendations in the report.

Most of our commercial NPP fleet has been relicensed by the Nuclear Regulatory Commission (NRC), for another 20 years of operation. To maintain a nuclear electric capacity beyond that point, we will have to consider building new capacity or relicensing existing plants, or both, to operate beyond the current extension. In either case, nuclear wastes will continue to be generated, spent fuel pools will have reached their capacity, and the nation will need a publicly acceptable approach to handling those wastes.

Daniel Metlay, **B. John Garrick**, and Nigel Mote lead off this issue with a concise history of global approaches to the handling of nuclear waste, in effect, a summary of past and present efforts in this country and abroad that have brought us to this point in terms of nuclear waste management. John is chairman of the U.S. Nuclear Waste Technical Review Board, Nigel is the Board's executive director, and Dan is a senior member of the professional staff.

In the next article, **Al Carnesale**, UCLA Chancellor Emeritus and a member of the BRC, discusses the BRC's findings and recommendations for handling nuclear wastes going forward in the United States. Taken as a whole, the conclusions and recommendations of the BRC provide a sound policy platform. In my view, two of the recommendations in particular stand out. First, the BRC recommends that decisions about the siting of future nuclear waste facilities be consent-based, that is,

that the affected public in proximity to a proposed site must agree to accept the presence of such a facility in its neighborhood. Second, the BRC recommends the development of short-term (or interim) storage facilities for nuclear waste as an intermediate step preceding ultimate disposal in a geologic disposal facility.

Note that “short-term storage” in this context might mean hundred(s) of years. However, engineers don’t typically think in terms of designing for a century or more of service. In addition, changes in the stored fuel over a period of centuries, and the consequences of those changes, are essentially unstudied. In the third article, Andy Kadak, former CEO of Yankee Atomic Nuclear Plant and a former member of the MIT Nuclear Science and Engineering faculty, focuses on issues associated with the continued storage of nuclear fuel, perhaps the most immediate challenge in terms of managing nuclear wastes. Next, James Rubenstone of the Nuclear Regulatory Commission describes the regulatory challenges associated with overseeing the management of nuclear wastes in this changing policy environment.

The perspective of the Nuclear Energy Institute (NEI), the policy organization of the nuclear industry, is presented by NEI President Marv Fertel. He provides a supply-side point of view on the path forward. Despite the industry’s record of safe and secure management of used nuclear fuel, he acknowledges that the public and policy makers still have serious concerns. Fertel identifies the federal government’s inaction in meeting its obligation under the Nuclear Waste Policy Act of 1982 as a source of the industry’s deep frustration in terms of the development of a sustainable solution to spent fuel management.

Public attitudes are a crucial factor in the national conversation about nuclear power, particularly about the location of interim storage sites or a long-term geologic repository. In the last article, Hank Jenkins-Smith and his colleagues from the Center for Risk and Crisis Management at the University of Oklahoma focus attention on public perceptions of risk and the factors that influence those perceptions.

I find it difficult to envision how any technical solution to the management of nuclear waste can succeed without a supportive public. Indeed, international experience associated with locating repositories described in this issue underscores the importance of public understanding and trust.

The evolution and shaping of public opinion pervade our social fabric from politics to education and health care and from the infrastructure to nuclear waste management. Unfortunately, shaping public opinion often means propagating misinformation for political gain, which has become all too familiar. In an ideal world, however, people can be encouraged to form opinions based on the best and most meaningful information available.

In the next issue of *The Bridge*, we will provide a broad-based discussion of the importance of social science in the engineering enterprise. Contributors will explore science-based and engineering-based approaches to solving public policy problems, the design of organizations that must operate at a high degree of reliability, the social amplification of risk from hazardous technologies, sources of public opinion about risky technologies, and engineering ethics.

The current issue of *The Bridge* and the companion issue that will follow in September are the first volumes published under my direction as Editor in Chief, and I welcome feedback from our readers. Send your comments directly to me at rlatanision@exponent.com. Perhaps at some point we will have a mechanism in place for reader reaction.

Finally, I wish to remember my predecessor, George Bugliarello, for his many years of service as “interim” editor and for his graceful sense of engineering statesmanship in guiding *The Bridge*. He has left us a wonderful legacy.



The siting of a deep-mined geologic repository requires strong bonds of trust between implementers, regulators, and the host community.

Management of Radioactive Waste

A Socio-Technical Challenge

Daniel Metlay, B. John Garrick, and Nigel Mote¹



Daniel Metlay



B. John Garrick



Nigel Mote

Few public policy issues rival the management of high-level radioactive waste (HLW) and spent nuclear fuel (SNF) in terms of the controversy it engenders and the demands it places on scientific research and engineering practice. High-activity waste,² first produced during the Manhattan Project, still evokes in the general public in the United States and abroad strong negative images that persist, at least in part, because of the failure of repeated

Daniel Metlay is a member of the Senior Professional Staff, U.S. Nuclear Waste Technical Review Board (NWTRB); B. John Garrick is chairman of the NWTRB and an NAE member; and Nigel Mote is executive director of the NWTRB staff.

¹ The U.S. Nuclear Waste Technical Review Board (NWTRB) is an independent federal agency charged with evaluating the technical and scientific validity of efforts by the Secretary of Energy to implement the Nuclear Waste Policy Act, as amended in 1987. The views expressed in this article are those of the authors and are not necessarily the views of the NWTRB.

² "High-activity waste" includes both HLW and SNF.

efforts to develop sustainable solutions that are defensible technically and politically.

Overview

High-activity waste is an inevitable by-product of the operation of nuclear reactors designed to generate either electricity or plutonium used in the fabrication of nuclear weapons. Although the final composition of SNF depends on a number of factors, such as its initial enrichment level, reactor type, and burnup level, fuel rods 10-years removed from a reactor typically contain several hundred different isotopic constituents. Collectively, these radionuclides fall into six categories and in the following proportions:

- uranium—95.6 percent (by mass)
- plutonium—0.9 percent
- minor actinides (e.g., neptunium, americium, etc.)—0.1 percent
- long-lived fission products (e.g., iodine, technetium, etc.)—0.2 percent
- short-lived fission products (e.g., strontium, cesium, etc.)—0.3 percent
- stable fission products (e.g., selenium, xenon, etc.)—2.9 percent

About 65,000 metric tonnes heavy metal of spent nuclear fuel are being stored at 78 locations in the United States.

HLW is first produced in liquid form when SNF is chemically processed to remove the preponderance of uranium, plutonium, and minor actinides. HLW contains mostly stable and long- and short-lived fission products, although some actinides may also be present. The liquid is then converted into a solid vitrified form by mixing it in canisters with molten glass. In some countries, such as Sweden, only SNF is disposed. In others, like France, only vitrified HLW is disposed. In still others, like the United States and Germany, both SNF and vitrified HLW are disposed.

The Inventory

In the United States, approximately 65,000 metric tonnes heavy metal (MTHM) of commercial SNF is currently being stored at the 78 sites where 125 large power reactors are operating or have been shut down. Roughly 40,000 MTHM is kept in shielded concrete pools. The remainder is in dry storage casks, which are set on concrete pads located on or close to the reactor sites. An additional 2,000 MTHM of commercial SNF is produced each year.

The U.S. Department of Energy (DOE) also owns a variety of high-activity waste forms, mostly generated as part of the nuclear weapons program. That material, located at four sites, includes nearly 2,500 MTHM of spent fuel and slightly more than 3,100 canisters of HLW. Finally, the federal inventory includes about 27 MTHM of SNF discharged from the reactors of nuclear-powered submarines and aircraft carriers.

Approaches to Long-Term Management

Although most of the radionuclides produced in a reactor pose only minor risks because of their negligible quantities, short half-lives, or insignificant biological effects, high-activity waste, if not managed properly, can seriously threaten human health and the environment. Although complete consensus on the acceptable risk has not been reached internationally, most countries have determined that long-term radiation risk to the public from exposure to high-activity waste should be limited to the level of risk from one or two chest x-rays a year. Most countries have also concluded that this level of protection will have to be sustained for hundreds of thousands of years (NWTRB, 2009).

Over the last half century, the technical community has advanced a variety of approaches for the long-term management of high-activity waste (IRG, 1978):

- shooting the waste into space
- disposing of the waste in the seabed
- burying the waste in the Antarctic ice sheet
- placing the waste in boreholes (several kilometers deep)
- depositing the waste in deep-mined geologic repositories 500 to 1,000 meters below the surface

For the moment at least, there is a strong international consensus about management options: all countries that operate nuclear reactors have focused solely on

developing deep-mined geologic repositories.³ Reflecting this consensus, the Radioactive Waste Management Committee of the Organization for Economic Cooperation and Development held that constructing a repository is “technically feasible” and would provide “a unique level and duration of protection” (NEA, 2008).

As will be discussed below, a variety of repository concepts have been proposed, but they all have some common features. The high-activity waste is packaged, either away from or at the repository site. The repository itself is built by excavating ramps or shafts that lead to locations in the geologic formation where the waste is to be emplaced. The waste packages are delivered in a shielded vehicle below ground and are either emplaced in vertical boreholes carved out of the host rock or are simply set on the drift (tunnel) floors. Once emplacement operations are complete, the drifts are backfilled, and the ramps or shafts are sealed. Figure 1 shows a representative layout of a deep-mined geologic repository.

As yet, no country has put a deep-mined geologic repository for high-activity waste into operation. Moreover, with the exception of Finland, every country that has attempted to site such a facility has experienced one or more setbacks that have necessitated substantial organizational and policy changes. Finland, along with Sweden and France (both of which recovered relatively rapidly after initial programmatic interruptions), has the most advanced schedules for managing high-activity waste. All three expect to commence disposition operations sometime between 2020 and 2025.

In the United States, where efforts to develop a repository began more than four decades ago, the situation is still unsettled. In 2002, Congress approved the siting of a deep-mined geologic repository at Yucca Mountain in the Nevada desert. In 2008, DOE submitted an application to the U.S. Nuclear Regulatory Commission (NRC) asking for approval to construct a facility.

Subsequently, the Obama administration announced that the Yucca Mountain repository was “not a workable option” and sought to withdraw the license application. At the same time, the Secretary of Energy appointed a Blue Ribbon Commission on America’s Nuclear Future (BRC or the Commission) to recom-

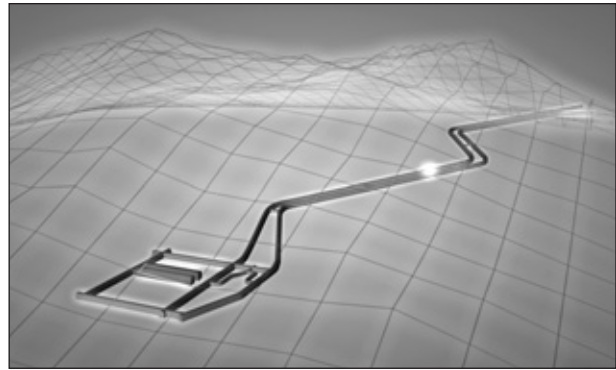

FIGURE 1 Schematic illustration of a repository for high-activity waste. Source: PURAM. Available online at <http://www.rhk.hu/en/photo-gallery>. Accessed on April 16, 2012.

mend an alternative path forward. In its final report, published in January 2012, the BRC calls for, among other things, the “timely” development of a repository based on a “consent-based” process (BRC, 2012). At the time of this writing, however, the fate of the recommendations is unclear. The NRC licensing proceeding for the Yucca Mountain repository has been suspended pending the outcome of a court case and future congressional appropriations.

Repository Concepts

In 1955, the National Academy of Sciences (NAS) sponsored a study to evaluate options for isolating and containing high-activity waste until radioactive decay had decreased the toxicity of the materials. Although the study committee noted that additional research was still needed, it concluded that “radioactive waste could be disposed of safely in a variety of ways and in a number of sites in the United States” and that “disposal in salt [was] the most promising method for the near future” (NAS, 1957, pp. 16–17).

Repositories in Salt

Salt is considered a particularly attractive host rock for a deep-mined geological repository because (1) its presence implies the absence of flowing water, which is the predominant vehicle for transporting to the environment materials that are eventually released from high-activity waste, (2) fractures arising in a salt formation are self-healing, and (3) the high thermal conductivity of salt would permit the construction of a facility with a small footprint. In addition, for a repository developed in a salt formation, the geology alone is sufficient to isolate and contain high-activity waste.

³ Management of high-activity waste requires a tightly integrated system capable of transporting the material from the sites where it is generated to, perhaps, plants where it is processed to extract residual fuel materials from the SNF, then to, perhaps, facilities where it might be stored temporarily, and finally to a deep-mined geologic repository for permanent disposal. This article focuses on the final step in the management process.

The NAS study was so influential that, during the 1960s and early 1970s, plans in the United States for disposing of high-activity waste were focused solely on developing a repository in salt. The German waste management program, also influenced by the study, has been focused on a salt repository since the 1970s.

Repositories in Clay Deposits

Many countries, however, do not have salt formations within their borders suitable for constructing a repository.⁴ Therefore, some have turned to indigenous clay deposits as an alternative.

For example, boom clay in Belgium, argillite in France, and opalinus clay in Switzerland have been identified as suitable host rocks for a deep-mined geologic repository. Clays can isolate and contain high-activity waste because (1) water moves extremely slowly through those strata, (2) clays can have a high sorptive capacity for radionuclides, and (3) fissures or fracture planes in the rocks close by themselves over time. Notably, like a salt repository, a clay repository would rely almost completely on geology to isolate and contain high-activity waste for millennia.⁵

Repositories in Crystalline Rock

A different approach has been taken by the Swedish and Finnish waste-management programs, and possibly by programs in Canada, Japan, and China. In their repository concept, waste isolation and containment would depend on both geology (natural barriers) and man-made structures (engineered barriers). Both kinds of barriers would be necessary for repositories in

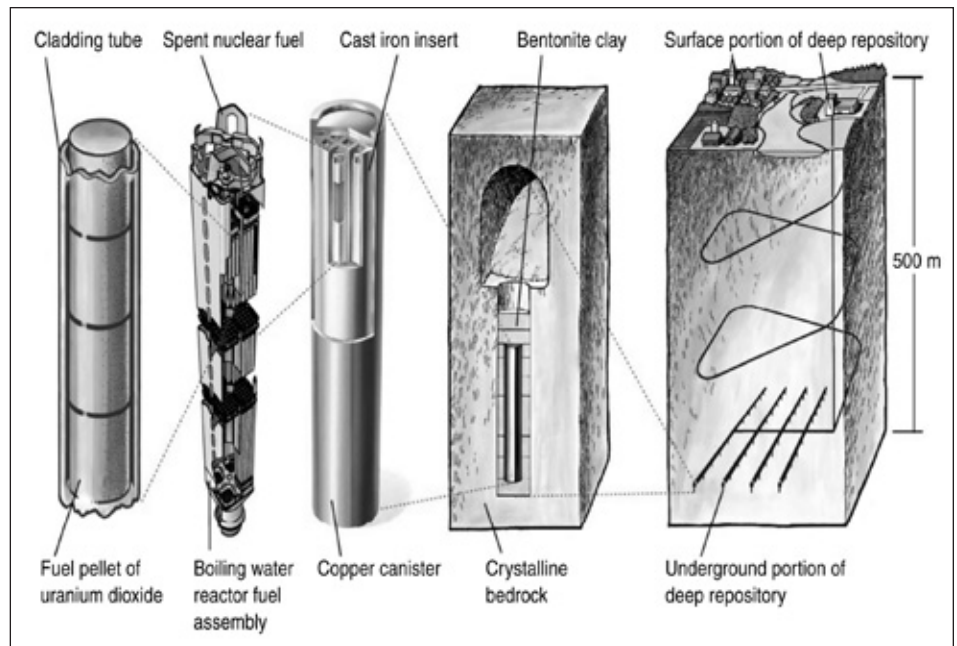

FIGURE 2 Design concept for a deep-mined repository in crystalline rock. Source: SKB. Available online at http://www.skb.se/Templates/Standard____24109.aspx. Accessed on April 16, 2012.

crystalline host rocks, such as granite or gneiss, which are pervasive in those countries.

For a repository in crystalline host rock (Figure 2), high-activity waste would first be loaded into a cylinder fabricated from cast iron or a similar material, which is not intended to provide long-term protection against corrosion. The package would then be lowered into an elemental-copper canister. The repository itself would be located in crystalline formations where the electrochemical, pH, and solute properties of the circulating groundwater would not challenge the structural integrity of the canister. The canisters would be emplaced in oversized shallow boreholes in the floor of the drifts, which would then be filled with blocks of bentonite clay, which can slow the movement of groundwater and capture high-activity waste that might migrate from the canisters.

A Repository in Tuff

A totally different concept evolved for Yucca Mountain, where the host rock is tuff (consolidated ash ejected from a volcano millions of years ago). Unlike any other site under consideration, the repository horizon at Yucca Mountain is *above* the water table. Because of this, it was initially believed that the tunnels would remain “dry,” making robust waste packages superfluous.

⁴ The established international principle is that each country should dispose of its high-activity waste within its own borders. Over the years, the possibility of developing a multinational repository has been explored, but so far, the idea has not matured beyond the talking stage.

⁵ In both concepts, the packages holding the high-activity waste are expected to isolate and contain the material for only several hundred years.

As the project advanced, however, site investigations revealed that water could seep into the drifts. Thus in the oxidizing environment that would surround the horizontally emplaced carbon-steel waste packages, corrosion suddenly emerged as a serious potential problem. To address this concern, a corrosion-resistant, nickel-based alloy was substituted for carbon steel as the material for the outer shell of the waste package, and drip shields made of titanium were introduced to deflect water that might seep into the drifts from above (Figure 3).

In the Yucca Mountain repository concept, at least according to DOE, the engineered barriers are designed to be robust enough to isolate and contain the high-activity waste almost indefinitely. Any radionuclides that eventually escape from the packages would move slowly, held up by natural barriers above and below the water table.

Attitudes and Beliefs

The recent turbulence surrounding the proposed repository at Yucca Mountain is only the latest instance in which public and political opposition have forced national waste-management programs to reassess their approaches and goals.

During the late 1980s and through the early 1990s, programs in a number of other countries also encountered formidable obstacles. In Canada, a proposed repository was debated at a series of public hearings, and Government ultimately concluded that the concept had achieved technical, but not social, acceptance. In Sweden, attempts to investigate potential sites in several communities were stopped when citizens blockaded access roads. In France, efforts to evaluate potential sites not only enflamed local communities but also triggered demonstrations nationally. In the United Kingdom, a proposal to construct a laboratory to conduct research underground failed to receive local

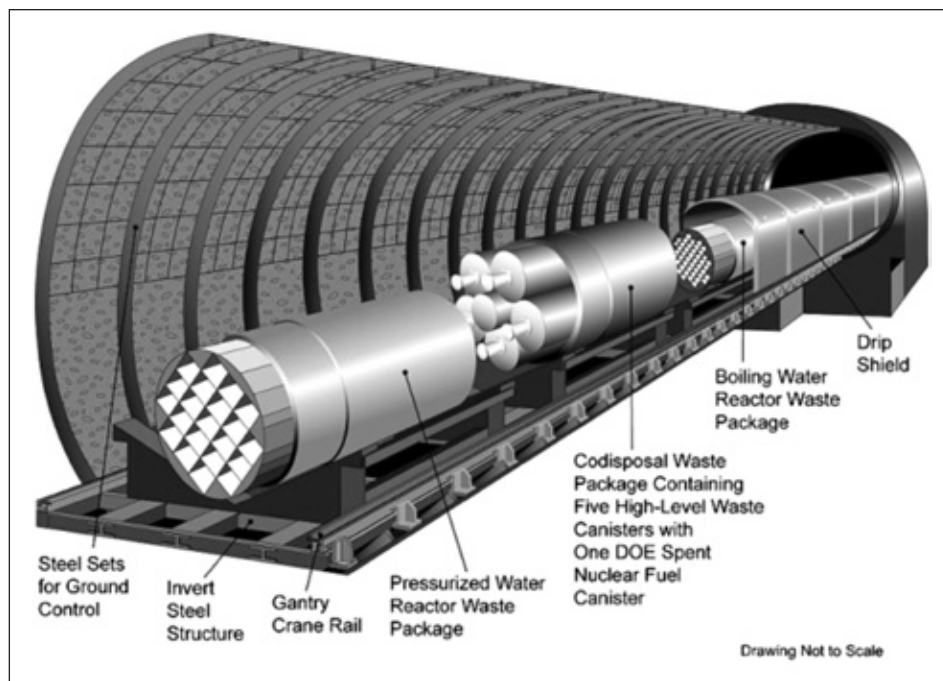

FIGURE 3 Design concept for the proposed Yucca Mountain repository. Source: DOE. Available online at <http://esmeraldanvnuke.com/yucca.html>. Accessed April 16, 2012.

“planning permission,” a decision that was later upheld by Government.

Public Perceptions of Risk

Cognitive psychologists and specialists in public opinion have produced a body of findings that provide insights into why the management of high-activity waste has elicited such strong reactions. These scholars have concluded that the general public perceives the risk of a technology or activity by evaluating—either consciously or subconsciously—more than a dozen factors.⁶ Consider one of them, familiarity. All other things being equal, the more an object or event is seen as *unfamiliar*, the greater the perceived risk (Slovic, 1987).

One study compared public perceptions of the risk of 30 technologies and activities and found, not surprisingly, that the risk of radioactive waste was perceived to be relatively high (Hinman et al., 1993). In fact, it evokes the strongest feelings (other than toward nuclear accidents and war) of uncontrollability, dread, and involuntariness. As one historian concluded, matters

⁶ The factors most often studied are: voluntary/involuntary; chronic/catastrophic; calm/dread; certainly not fatal/certainly fatal; known to be exposed/not known to be exposed; immediate/delayed; known to science/unknown to science; controllable/not controllable; and familiar/unfamiliar.

nuclear strike an especially discordant bell for the public (Weart, 1988).

Importantly, the general findings about risk perceptions of radioactive waste in the United States are similar to perceptions in other countries. In the comparative study just mentioned, radioactive waste was found to produce almost exactly the same strong feelings of uncontrollability and dread in the Japanese public. Research into perceptions of risk held by the general public in Sweden, France, and the Netherlands is also strongly consistent with the conclusions about the perceptions of Americans (e.g., Sjöberg, 2003, and Wiegman et al., 1995).

Perhaps more revealing were the results of a research project carried out under the auspices of the European Commission (EC, 2008). More than 26,000 residents of the 27 member states of the European Union were interviewed about their attitudes toward the management of radioactive waste. As part of the survey, individuals were asked whether they agreed or disagreed with the following statement, “There is no safe way of getting rid of high-level radioactive waste.” Although one might quibble with the wording, the unambiguous results cannot be explained away simply by advancing a methodological critique. Overall, 72 percent of the respondents either totally agreed or tended to agree with the statement. Only 14 percent disagreed.

In a 2008 survey of 26,000 EU citizens, 72 percent agreed that “there is no safe way of getting rid of high-level radioactive waste.”

A breakdown of the aggregate results of the study yields valuable insights. In Finland, France, and Sweden—the three countries with the most advanced repository programs—82 percent of those surveyed concurred with the statement. Lithuanians, Hungarians, Latvians, and the Dutch were most inclined to disagree, although a majority in each of those countries did agree.

In addition, risk perceptions did not vary by age, education level, or by the respondents’ level of information about radioactive waste. And, contrary to expectations,

risk perceptions were not strongly influenced by political philosophy. Of the people who identified with right-wing ideologies, 71 percent agreed with the statement. Of those who identified with left-wing ideologies, 77 percent agreed.

Only one significant demographic difference was reported. Fewer individuals who were in favor of nuclear energy production *totally* agreed with the statement than those who opposed nuclear energy production (36 versus 50 percent). However, when these numbers were added to the percentages of respondents who *tended* to agree, the sums were comparable.

The general public’s perceptions of risks associated with radioactive waste (at least as imperfectly measured by opposition to the siting of a repository) may or may not change over time. In the case of the Waste Isolation Pilot Plant (WIPP)⁷ located in New Mexico, attitudes became markedly more favorable as the public in that state gained experience with the facility’s operation. Opposition fell from nearly 60 percent in 1995 to 35 percent in 2000 (Jenkins-Smith et al., 2009). By contrast, for the last quarter century, public disapproval in Nevada of the proposed repository at Yucca Mountain has never dropped below the 65 to 70 percent range.

Technical Specialists’ Perceptions of Risk

Risk perceptions of technical specialists typically differ from the perceptions of the general public, although not in easily predictable ways (Bostrom, 1997). The few systematic studies that have been undertaken suggest that experts perceive the risks associated with managing high-activity waste to be significantly lower than the general public does (Flynn et al., 1993). For example, whereas 60 percent of the general public in a national survey disagreed with the statement that “buried waste will be contained in the waste site so that contamination of underground water supplies will not occur,” only 14 percent of those surveyed at a meeting of the American Nuclear Society dissented. But even technical experts do not perceive the risks uniformly. The risks perceived by medical researchers, for example, are 50 percent higher than by physicists (Barke and Jenkins-Smith, 1993).

From the perspective of those responsible for developing a system for managing high-activity waste,

⁷ WIPP is only authorized to accept transuranic-contaminated waste from the U.S. defense complex, not the high-activity waste that is the focus of this article.

information about risk perceptions may only be of academic interest. However, attitudes about managing radioactive waste can be translated directly into public policy, at least in the United States and some European nations, when initiatives and referenda are voted on. They can also be indirectly translated into public policy if the issue becomes highly salient in political campaigns, as it did in Sweden and Germany.

The Issue of Trust

Research suggests that risk perceptions of the development of a deep-mined geologic repository have more nuanced implications. Over the last 20 years, a significant body of literature has emerged linking risk perceptions with trust in the institutions charged with managing those risks (e.g., Cvetkovich and Löfstedt, 1999).

The dominant view is that trust affects beliefs, and so the more trustworthy the institution (all other factors being equal), the more perceptions of risk will be diminished (Flynn et al., 1992). As a practical matter then, if the implementer and regulator of national waste management programs can sustain a high level of trust, the chances of opposition being mobilized simply because of a perceived high level of risk tend to be lower. The converse also holds true.

Alternatively, the direction of the causal arrow can be reversed, that is, risk perceptions can influence the level of public confidence in the managing institutions.⁸ The implications of this reversal might be far-reaching. If the risk of managing high-activity waste were perceived to be low, then the public would be more likely to trust the scientific and technical judgments of implementers and regulators.⁹ The converse also holds true. We return to this point below.

Siting a Deep-Mined Geologic Repository

Given deep-seated public concerns about the risks associated with managing high-activity waste, it is hardly surprising that siting efforts worldwide have generally been unsuccessful. Since the 1970s, roughly two dozen initiatives have been launched to identify technically and politically suitable sites for deep-mined geologic repositories. As noted above, only three of those efforts are still on track (NWTRB, 2011).

Technical Obstacles

Sometimes the obstacles have been technical. For example, in the late 1960s, the U.S. Atomic Energy Commission began investigating a salt site near Lyons, Kansas. Although this study provoked intense political opposition at the state level, the project was ultimately doomed by the investigators' inability to account for the substantial amount of water that was routinely used to solution-mine the mineral.

In the mid-1990s, the French implementing organization, ANDRA, sought volunteer communities to host two underground research laboratories (URLs), one situated in clay and the other in granite. Two communities stepped forward. However, when the Committee of National Evaluation, the French technical oversight body at the time, reviewed the geology of each site, it concluded that the proposed granite site was too complex to be adequately characterized.

Risk perceptions are linked to trust in the institutions charged with managing them.

Political Obstacles

More frequently, the obstacles to siting have been political. The controversies that adversely affected programs for managing high-activity waste in Canada, Sweden, France, the United States, and the United Kingdom have already been touched upon. The situations in Germany and Japan, however, illustrate how intense public reactions can effectively paralyze a country's waste-management program for decades.

More than 30 years ago in Germany, a salt site was identified near the town of Gorleben in Lower Saxony that might be suitable for development as a deep-mined geologic repository. Experiments were conducted and seemed to support the view that high-activity waste could be isolated and contained there for millennia. Although investigations continued, opponents at the national level maintained that the process for selecting the site had been flawed. That opposition delayed any final decision about the suitability of the site for many years.

The formation of a governing coalition in 1998 between the Socialist and Green parties effectively

⁸ Most likely, perceptions and trust are reciprocally related.

⁹ This perspective is developed in Kunreuther and Easterling, 1995.

derailed consideration of the site for almost another 10 years. But with the return to power of the Christian Democratic Party in 2010, the way seemed paved for a determination that the Gorleben site was suitable, and work on the project to develop a repository was resumed. However, in the aftermath of the Sendai tsunami in Japan that disabled the Fukushima-Daiichi reactors in 2011, Germany is again revisiting its repository-siting strategy.

Years of interaction between implementers and potential host communities can create strong bonds of social trust.

Even before the tsunami struck, the waste-management program in Japan was mired in controversy. In 2002, the implementing organization adopted what appeared to be the “best-practice” approach for selecting a repository site. Very general technical criteria were published specifying the geologic features that *automatically disqualified* a site from consideration.

Volunteer communities were sought; they only had to agree to paper and desk studies to ascertain whether nearby formations *might* be suitable. In addition, substantial benefit packages were offered to communities that agreed to the evaluations, and the communities could opt out of the process up until the time that significant work underground had commenced. Still, only one mayor was prepared to volunteer. And then, almost immediately, prefecture governors objected, and the mayor was recalled. No other community leader has stepped forward since.

The situation is not entirely bleak, however, at least in Europe. After years of patient interaction with local communities, implementers in Finland, France, and Sweden have selected potential sites for deep-mined geologic repositories, and leaders of the chosen districts have embraced the prospect of hosting such facilities.

Lessons Learned

Lessons from all of these siting experiences have not been lost on the directors of national waste-management

programs.¹⁰ Siting efforts now under way in Canada and the United Kingdom reflect these lessons, and the recommendations by the BRC in the United States are in line with this “new” understanding:

- *Potential host communities must at least acquiesce to site investigations.* Carlsbad, the closest town to WIPP, aggressively lobbied for the facility. The Meuse and Haute-Marne districts in France welcomed the construction of a URL, knowing that if the argillite there was suitable, a full-scale repository might be constructed nearby. The town of Eurajoki in Finland and the municipality of Osthrammar in Sweden responded positively to invitations from the two national implementers, Posiva and SKB, respectively.
- *Implementers must work intensively to engage potential host communities by establishing a strong, long-term local presence.* DOE required that officials involved with the WIPP project and researchers from national laboratories move to Carlsbad, New Mexico. In France, a Local Information and Oversight Committee has been established so that representatives of communities in the Meuse and Haute-Marne districts can continuously interact with ANDRA. In Sweden and Finland, the potential repository host communities had already become familiar with the implementers, because they (or their consortium members) had operated nuclear reactors at those sites for a long time. In each case, however, interactions were intensified when the municipalities began to be considered as potential locations for deep-mined geologic repositories.
- *Potential host communities must have a realistic, practical way to withdraw from the siting process.* The state of New Mexico was a full partner in negotiating the terms of the Land Withdrawal Act that permitted WIPP to operate. In France, the districts in question willingly accepted the prospects of hosting a deep-mined geologic repository when they volunteered to host the research laboratory. In Finland, Eurajoki’s consent was required before the Parliament could pass the “decision-in-principle” to site the proposed geologic repository. In Sweden, Osthrammar must agree to the granting of a license by Government. If the municipality should decide for some unexpected

¹⁰ The Japanese experience is typically discounted and dismissed as a deviant case, even though Japan’s federal structure makes it the most relevant example for informing future siting initiatives in the United States.

reason to exercise its veto power, the veto could, in theory, be overridden by Government. As a pragmatic matter, however, national culture and historical precedents would make such an override highly unlikely.

One consequence of implementers engaging potential host communities in a sustained and serious way appears to be the formation of strong bonds of social trust. The existence of those bonds is documented in both anecdotal evidence and systematic public opinion polls. For instance, from 2000 to 2005, mean social trust rose significantly among both men and women in Osthamar (Sjöberg, 2004, 2006). At the same time, mean perceived risk associated with the management of high-activity waste declined among women, even though the risk perceived by men, already very low, did not change. Attitudes toward a potential repository improved markedly among both men and women.¹¹

Site Characterization and Regulatory Compliance

Once the implementer has at least tentatively selected a site for a deep-mined geologic repository, the characterization process accelerates. Considerable information can be derived from experiments in a URL, such as those established in France and Sweden. But, at some point, site-specific data must be gathered. In some countries, including France and Sweden, as well as at WIPP in the United States, only surface-based testing is allowed until formal approval has been obtained from the authorities to break ground. In others, such as Finland and in the United States at Yucca Mountain, underground investigations were allowed to begin at an early stage.

Designing a research strategy for verifying the suitability of a site and ultimately developing arguments about the long-term safety of a repository is always time consuming and may, in some cases, be simpler in theory than in practice. For repositories where natural barriers will mostly isolate and contain the high-activity waste (e.g., salt and clay), the key parameters to be evaluated are well understood. How, for instance, does salt respond to heat? How permeable is the clay?

For repositories where engineered barriers will contribute importantly to long-term repository performance,

characterization must include assessments of *interactions* between the man-made and geologic components of the repository system. For a repository situated in a granitic formation, understanding some of those interactions may not be especially challenging. What, for example, is the permeability of the bentonite? However, other interactions may be harder to evaluate. For example, will the groundwater suffusing the repository corrode the copper canisters?

In a repository situated in tuff, like the proposed Yucca Mountain facility, understanding the interactions between the two types of barriers is probably even more difficult. How much water will infiltrate the drifts? What will its chemical composition be? Will the drip shields and nickel-alloy waste packages be vulnerable to attack either by dripping water or deliquescent salts that may form on the surface of the waste packages? What will be the source term if the engineered barriers are compromised?¹²

Regardless of the design concept, the implementers of national waste-management programs face similar scientific and technical challenges in projecting the behavior of repository systems for hundreds of thousands of years. Although laboratory experiments and *in situ* testing produce valuable data, the long-term performance of a deep-mined geologic repository can only be projected using complex, interdependent computer-based models of various scenarios that could affect how a repository might behave.

Significant unresolvable uncertainties are bound to be present in any projection of repository performance.

Depending on the regulatory philosophy in different countries, the models may be deterministic, probabilistic, or a combination of the two. The assessment of the modeling by regulators, and, in some nations, by Government, will determine whether the deep-mined geologic repository can be constructed and operated.

¹¹ Although the Swedish study did not examine the causal connection between social trust and perceived risk, the findings are consistent with the American study, cited above, which did model the relationship between the two variables.

¹² "Source term" refers to the rate of release and the composition of radioactive materials that eventually flow from the waste packages.

It is worth noting that trust and risk perceptions may affect how the regulatory process plays out. For example, if perceptions of risk can be lowered, key stakeholders may be more inclined to trust the scientific and technical judgments of both implementers and regulators. Such confidence may be a crucial ingredient in a challenging regulatory process, because significant unresolvable uncertainties are bound to be present in any projection of repository performance.

Conclusion

Few public policy issues rival the management of high-activity radioactive waste in terms of demands on scientific research and engineering practice and the controversy they engender. After decades of dedicated work in more than a dozen nations, evidence is beginning to increase confidence that “solutions” can be found to this pressing environmental problem. More important, lessons are being learned about how to design social processes that lead to technically and politically defensible outcomes. Given this progress, and because the stakes are so high, it would be unfortunate if temporization displaced action.

References

- Barke, R., and H. Jenkins-Smith. 1993. Politics and scientific expertise: scientists, risk perception, and nuclear waste policy. *Risk Analysis* 13(4): 425–439.
- Bostrom, A. 1997. Risk perceptions: “experts” vs. “lay people.” *Duke Environmental Law and Policy Forum* 8(3): 101–113.
- BRC (Blue Ribbon Commission on America’s Nuclear Future). 2012. Report to the Secretary of Energy. Washington, D.C.
- Cvetkovich, G., and R. Löfstedt, eds. 1999. *Social Trust and the Management of Risk*. London: Earthscan.
- EC (European Commission). 2008. *Special Eurobarometer 297: Attitudes Towards Radioactive Waste*. Brussels, Belgium: European Commission.
- Flynn, J., W. Burns, C. Mertz, and P. Slovic. 1992. Trust as a determinant of opposition to a high-level radioactive waste repository: analysis of a structural model. *Risk Analysis* 12(3): 417–429.
- Flynn, J., P. Slovic, and C. Mertz. 1993. Decidedly different: expert and public view of risks from a radioactive waste repository. *Risk Analysis* 13(6): 643–648.
- Hinman, G., E. Rosa, R. Kleinhesslink, and T. Lowinger. 1993. Perceptions of nuclear and other risks in Japan and the United States. *Risk Analysis* 13(4): 449–455.
- IRG (Interagency Review Group on Nuclear Waste Management). 1978. *Subgroup Report on Alternative Technological Strategies for the Isolation of Nuclear Waste, Appendix A, TID-28818 (draft)*. Washington, D.C.: IRG.
- Jenkins-Smith, H., C. Silva, M. Nowlin, and G. deLozier. 2009. Reevaluating NIMBY: evolving public fear and acceptance in siting a nuclear waste facility. Paper presented at the Midwest Political Science Association Annual Meeting, Chicago, Illinois.
- Kunreuther, H., and D. Easterling. 1995. *The Dilemma of Siting a High-Level Radioactive Waste Repository*. Boston: Kluwer.
- NAS (National Academy of Sciences). 1957. *Disposal of Radioactive Waste on Land*. Washington, D.C.: National Academy Press.
- NEA (Nuclear Energy Agency). 2008. *Moving Forward with Geological Disposal of Radioactive Waste: An NEA RWMC Collective Statement*. NEA-6433. Paris: Organization for Economic Cooperation and Development.
- NWTRB (Nuclear Waste Technical Review Board). 2009. *Survey of National Programs for Managing High-Level Radioactive Waste and Spent Nuclear Fuel*. Washington, D.C.: NWRTB.
- NWTRB. 2011. *Experience Gained from Programs to Manage High-Level Radioactive Waste and Spent Nuclear Fuel in the United States and Other Countries*. Washington, D.C.: NWTRB.
- Sjöberg, L. 2003. Attitudes and risk perceptions of stakeholders in a nuclear waste siting issue. *Risk Analysis* 23(4): 739–749.
- Sjöberg, L. 2004. Local acceptance of a high-level nuclear waste repository. *Risk Analysis* 24(3): 737–749.
- Sjöberg, L. 2006. Nuclear waste risk perceptions and attitudes in siting a final repository for spent nuclear fuel. Pp. 453–461 in *Proceedings of the VALDOR 2006 Conference*, edited by K. Andersson, Stockholm, Sweden.
- Slovic, P. 1987. Perception of risk. *Science* 236(4799): 280–285.
- Weart, S. 1988. *Nuclear Fear: A History of Images*. Cambridge, Mass.: Harvard University Press.
- Wiegman, O., J. Gutteling, and B. Cadet. 1995. Perceptions of nuclear energy and coal in France and the Netherlands. *Risk Analysis* 15(4): 513–521.

*According to the president's Blue Ribbon Commission,
“We know what we have to do, we know we have to
do it, and we even know how to do it.”*

Recommendations by the Blue Ribbon Commission on America's Nuclear Future

A Plan for Managing Spent Nuclear Fuel and High-Level Nuclear Waste



Albert Carnesale is Chancellor Emeritus and professor at the University of California, Los Angeles, and an NAE member.

Albert Carnesale

As a candidate for president in 2008, Barack Obama stated that “The nuclear waste disposal efforts at Yucca Mountain have been an expensive failure and should be abandoned” (Nature, 2008). Thus it should have come as no surprise when newly elected President Obama announced his decision to terminate the Yucca Mountain Nuclear Waste Repository project and initiated the development of a new plan for managing spent nuclear fuel and high-level nuclear waste.¹

On January 29, 2010, the White House released a memorandum from the president to Secretary of Energy Steven Chu directing him to establish a Blue Ribbon Commission on America's Nuclear Future (the Commission) and to appoint its members (White House, 2010):

The Commission should conduct a comprehensive review of policies for managing the back end of the nuclear fuel cycle, including all alternatives for the storage, processing, and disposal of civilian and defense used nuclear fuel and nuclear waste. This review should include an evaluation of advanced fuel cycle technologies that would optimize energy recovery, resource utilization, and the minimization of materials derived from nuclear activities in a manner consistent with U.S. nonproliferation goals.

¹ The courts will ultimately decide whether or not the president has the authority to terminate the project.

In performing its functions, the Commission should consider a broad range of technological and policy alternatives, and should analyze the scientific, environmental, budgetary, economic, financial, and management issues, among others, surrounding each alternative it considers. Where appropriate, the Commission may also identify potential statutory changes.

The President also specified that the Commission release an interim report for public comment within 18 months and provide a final report to the Secretary of Energy within 24 months.

Coincidental with the release of the President's memorandum, Secretary Chu announced the formation of the Commission and its membership (DOE, 2010). The co-chairs—Lee Hamilton and Brent Scowcroft—both had distinguished records of public service, were known to be successful problem solvers and effective leaders, and were respected across the political spectrum. Although neither was an expert on the back end of the nuclear fuel cycle, other members of the Commission had technical expertise in relevant academic disciplines. In addition, the Commission included former elected and appointed officials and representatives of industry, labor, and nongovernmental organizations.

*The Commission concluded
that a new approach
could be adopted and
implemented successfully.*

Soon after Secretary Chu's announcement, the Commission was formally established, and by January 2012, it had fulfilled its mission and delivered its final report, *Report to the Secretary of Energy* (hereinafter referred to as the BRC report) (BRC, 2012).² This article is based largely on the author's participation as a member of the Commission and draws heavily on the language of the report.

The Commission's overarching task was to recommend a workable strategy for managing nuclear waste.

Although this charge was broad in scope, it is important to note three tasks that were *not* included in the Commission's purview: (1) reviewing the administration's decision to withdraw the application for a license for construction at Yucca Mountain; (2) identifying or evaluating potential sites for nuclear waste management facilities; and (3) recommending appropriate levels of America's future reliance on nuclear power.

The Current Situation

Clearly, past strategies for dealing with spent nuclear fuel and high-level waste have failed, and the United States has been trying to figure out what to do with these materials for more than five decades. Although 25 years have passed since the 1987 amendments to the Nuclear Waste Policy Act (NWPA) were enacted, the results have been largely controversy, litigation, and delays.

All this time, utility customers have been paying the federal government one mill (0.1 cent) per kilowatt-hour of nuclear-generated electricity to finance the government's commitment to assume responsibility for dealing with spent nuclear fuel and high-level waste. Unfortunately, this "solution" has not materialized, nor is it anywhere in sight.

Instead, spent nuclear fuel continues to accumulate in storage pools and dry casks at reactor sites, and defense and commercial high-level waste have no place to go. Moreover, taxpayers face mounting liabilities arising from the federal government's failure to meet its commitments regarding commercial spent fuel. As a result, confidence in the government's ability to meet its legal obligation has all but disappeared.

America's failure to deal with the back end of the nuclear fuel cycle has been more than expensive. It has also undermined prospects for nuclear energy and lessened our nation's ability to lead on global issues of nuclear safety, nonproliferation, and security. In light of this situation, the Commission concluded that we urgently need a new strategy (BRC, 2012, p. vi).

Furthermore, the Commission maintained that a new approach could be adopted and could be implemented successfully (BRC, 2012, p. 4). This optimism was based largely on two factors. First, proceeding down the current path would not only be increasingly time-consuming, costly, controversial, and divisive, but it would also offer little if any prospect for success. Second, experience at home and abroad has provided some concrete examples of progress in dealing with

² This is the Commission's final report. Reports of BRC subcommittees on reactor and fuel-cycle technology, transportation and storage, and disposal, as well as related materials are available on the Commission's website at www.brc.gov.

nuclear waste (e.g., successful operation of the Waste Isolation Pilot Plant [WIPP], a disposal facility for transuranic defense waste in New Mexico; the selection of a site for storing spent fuel in Spain; and the selection of sites for permanent repositories in Finland and Sweden).

A New U.S. Strategy

The strategy recommended by the Commission has eight key elements (BRC, 2012, p. vii):

1. A new, consent-based approach to siting future nuclear waste management facilities.
2. A new organization dedicated solely to implementing the waste-management program and empowered with the authority and resources to succeed.
3. Access to the funds nuclear utility ratepayers are providing for the purpose of nuclear waste management.
4. Prompt efforts to develop one or more geologic disposal facilities.
5. Prompt efforts to develop one or more consolidated storage facilities.
6. Prompt efforts to prepare for the eventual large-scale transport of spent nuclear fuel and high-level waste to consolidated storage and disposal facilities when such facilities become available.
7. Support for continued U.S. innovation in nuclear energy technology and for workforce development.
8. Active U.S. leadership in international efforts to address safety, waste management, non-proliferation, and security concerns.

None of these elements will be new to those who have followed the U.S. nuclear waste program over the years. These ideas have been around for a long time but haven't been tried, whereas the (equally) old ideas that characterize the current program have been tried and have failed.

The eight elements in the new strategy are interconnected and, to a great extent, interdependent, and no doubt, it will take years to implement them fully. However, in light of the urgent need to deal with America's nuclear waste, prompt action should be taken whenever possible. Some actions can be taken independently by the Executive Branch; others will require legislative action to amend the NWPA and other relevant laws. Each element of the recommended strategy is discussed in more detail below.

A Consent-Based Approach to Siting

The first recommendation calls for the United States to adopt a new consent-based approach to siting and developing facilities for the management and disposal of nuclear waste (BRC, 2012, p. xi).³

The Commission conducted an in-depth review of siting efforts, both successful and unsuccessful, in the United States (viz., the operating WIPP facility in New Mexico, several failed attempts to site monitored retrievable storage facilities for commercial spent nuclear fuel, and the Yucca Mountain saga) and in Canada, Finland, France, Japan, Russia, Spain, Sweden, and the United Kingdom. On the basis of this review, the Commission concluded that siting processes are most likely to succeed if they have the following characteristics (BRC, 2012, pp. 47–48):

The Commission's ideas are not new, but none of them has been tried before.

1. Consent-based—in the sense that affected communities have an opportunity to decide whether to accept facility siting decisions and retain significant local control.
2. Transparent—in the sense that all stakeholders have an opportunity to understand key decisions and engage in the process in a meaningful way.
3. Phased—in the sense that key decisions are revisited and modified as necessary along the way rather than being pre-determined.
4. Adaptive—in the sense that the process itself is flexible and produces decisions that are responsive to new information and new technical, social, or political developments.
5. Standards- and science-based decisions—in the sense that the public can have confidence that all facilities meet rigorous, objective, and consistently applied standards of safety and environmental protection.
6. Governed by partnership arrangements or legally enforceable agreements between the implementing

³ The BRC differentiates between "storage" and "disposal" in the following way: "disposal" refers to permanent disposal; "storage" refers to storage for an interim period prior to disposal or other disposition.

organization and host states, tribes, and local communities.

Yucca Mountain has been designated by the NWPA and subsequent legislation as the site for a deep geological nuclear waste depository, subject to approval by the Nuclear Regulatory Commission (NRC). In addition, Congress has specified that no more than 70,000 metric tons of spent nuclear fuel can be deposited in Yucca Mountain before a second repository is in operation. However, because the U.S. commercial inventory of spent nuclear fuel already exceeds 65,000 metric tons, regardless of the fate of the Yucca Mountain site, a second depository will be needed.

The Commission estimates it would take 15 to 20 years to identify, characterize, and license a deep geologic depository and 5 to 10 years to site and develop a consolidated storage facility.

The first requirement to be met in siting a facility is to affirm that public health and safety and the environment will be adequately protected. In addition, experience in the United States and elsewhere has shown that beyond meeting this basic criterion, successful siting requires that “all affected units of government, including the host state or tribe, regional and local authorities, and the host community are willing to support or at least accept a facility” (BRC, 2012, p. viii).

After basic siting criteria have been developed, the organization responsible for site selection should seek expressions of interest from a number of communities that might have suitable environments for the kind of facility under discussion. As the process moves forward, all stakeholders—states, tribes, local communities, nongovernmental organizations, and citizens—must be engaged meaningfully, and funds should be provided to enable such engagement.

In addition, incentives should be provided to encourage affected states, tribes, and local governments to host

a nuclear waste facility. Such incentives might take the form of direct financial payments, local preferences in hiring and purchasing by the facility, infrastructure improvements, and so forth.

As the final selection approaches, it would be desirable for the responsible organization and the host jurisdictions to enter into partnership arrangements or other legally binding, court-enforceable agreements to ensure that all commitments concerning the development and subsequent operation of the facility are fully understood by all parties and will be upheld (BRC, 2012, p. 56).

The Commission recognizes that implementation of the recommended consent-based process would take more time than a top-down process but believes that the flexibility of the new process and the public trust it would engender would increase the likelihood of success. The Commission estimates it would take on the order of 15 to 20 years for site identification, characterization, and licensing for a deep geologic depository and 5 to 10 years for the siting and development of a consolidated storage facility (BRC, 2012, p. 55).

Establishment of a Single-Purpose Organization

The second central recommendation of the BRC calls for the establishment of a new, single-purpose, independent organization dedicated solely to implementing the nation’s nuclear waste management program.

A new organization focused exclusively on the safe, secure management and ultimate disposal of high-level nuclear waste could concentrate on this objective in a way that a large, multipurpose agency, such as the U.S. Department of Energy (DOE), cannot. Also, given the discouraging history of attempts by DOE and its predecessor agencies to deal with the nuclear waste problem, establishment of a new agency would signal a clear break with the past and would offer the best chance of regaining the trust and confidence of the public and major stakeholders.

To succeed, the new organization must have a structure and governance system suited to the task, as well as appropriate authorities and resources. The Commission recognizes that an appropriate structure could take any of a number of forms, provided that it has the attributes, independence, and resources to carry out its mission. Of the possible forms, the Commission is inclined to favor a federal corporation chartered by Congress, because it would “(a) be less susceptible to political micromanagement, (b) have more flexibility to respond to changes in external conditions, and

(c) have a greater ability to manage costs and schedules” (BRC, 2012, pp. 61–62).

For example, the federal corporation might have a board of directors consisting of 11 members: 10 appointed by the president, with the advice and consent of the Senate, and a board-appointed CEO of the organization. The board would provide management and fiduciary oversight and operational direction. A separate advisory group, reflecting a wider range of perspectives, would provide advice to the corporation and the board.

The new entity must be both independent and accountable—always a delicate balancing act. Independent regulatory agencies, such as NRC, the Environmental Protection Agency, the U.S. Department of Transportation, and the Occupational Safety and Health Administration, would apply the same safety, health, and environmental regulations to the new federal corporation as they would apply to a private organization. To ensure that Congress and the American people can be confident that the federal corporation is acting responsibly and using public resources wisely and appropriately, Congress would pass legislation defining the mission, structure, responsibilities, and powers of the organization.

Notable by its absence from the Commission’s considerations of safe, secure management and ultimate disposal of high-level nuclear waste is the reprocessing of spent nuclear fuel. This deliberate omission reflects the Commission’s view that “no currently available or reasonably foreseeable reactor and fuel cycle technology developments—including advances in reprocessing and recycling technologies—have the potential to fundamentally alter the waste management challenges the nation confronts over at least the next several decades, if not longer” (BRC, 2012, p. 101). Based on this view, the Commission concluded that “it would be premature for the United States to commit, as a matter of policy, to ‘closing’ the nuclear fuel cycle given the large uncertainties that exist about the merits and commercial viability of different fuel cycle and technology options” (BRC, 2012, pp. xi–xii).

Ensuring Access to Funds

The Commission’s third central recommendation is that the new organization should have access to “the revenues generated by the nuclear waste fee and the balance in the NWF [Nuclear Waste Fund]... when needed and in the amounts needed to implement the program” (BRC, 2012, p. 70).

For almost three decades, nuclear utilities have been paying a nuclear waste fee into the NWF, which is intended solely to cover the cost of disposing of commercial nuclear waste. Cumulative receipts thus far exceed \$19 billion, and the amount is growing by about \$750 million per year. With accumulated interest, the NWF balance is now about \$27 billion. (In contrast, the costs of disposing of defense nuclear wastes are paid for by taxpayers through direct appropriations from the U.S. Treasury.)

A series of decisions by the Executive Branch and congressional actions has made the annual fee revenues and the unspent balance in the NWF effectively unavailable to the civilian nuclear waste program. Instead, contrary to the original intent of Congress, waste management needs have had to compete for limited discretionary funds with other DOE priorities in the appropriations process. The Commission concludes that (1) the nuclear waste funding mechanism must be allowed to work as originally intended so that funding for the waste program is no longer subject to unrelated federal budget constraints, and (2) the new waste management organization should be entrusted with greater autonomy and control of its budget over multiple-year periods (BRC, 2012, p. 74).

Contrary to the original intent of Congress, annual revenues and the unspent balance of the Nuclear Waste Fund are not available to the civilian nuclear waste program.

Accordingly, the Commission recommends: (1) that the administration modify the nuclear waste fee collection process so that utilities pay only an amount equal to actual appropriations from the NWF each year, with the remainder retained by the utilities in approved trust funds to be available to meet future needs; (2) that the administration and Congress change the budgetary treatment of the fee receipts so they can directly offset appropriations for the waste program; and (3) that in the longer term, Congress transfer the unspent balance

in the NWF to the new waste management organization (BRC, 2012, pp. 74–75).

Delay in implementing a U.S. nuclear waste management program has also been very costly in other ways. Because of the government’s failure to meet its obligation to remove spent fuel from reactor sites, affected utilities have incurred unanticipated costs for on-site storage. They and DOE have been engaged since 1998 in litigation over how much the government (i.e., taxpayers) must pay in damages. Final judgments and settlements to date have cost about \$2 billion; estimated total damages through 2020 are about \$20.8 billion; and the estimated annual increase for each year beyond 2020 is on the order of \$500 million (BRC, 2012, p. 80).

Timely Development of Geologic Disposal Facilities

The fourth central recommendation is that the United States undertake an integrated nuclear waste management program that leads to the timely development of one or more permanent deep geological facilities for the safe disposal of spent fuel and high-level nuclear waste (BRC, 2012, p. 27).

Safety, responsibility to future generations, and cost all argue for prompt development of one or more deep geologic repositories.

Safety, responsibility to future generations, and cost all argue for prompt efforts to develop one or more deep geologic repositories, which is the only known responsible way of managing nuclear materials that are unlikely to be re-used, including many forms of spent fuel and defense and commercial reprocessing wastes. This conclusion has been reached by every expert panel in the United States that has addressed the issue and by every other country pursuing a nuclear waste management program. The reprocessing and recycling of commercial spent fuel would not alter this conclusion, because all reprocessing or recycling options generate waste streams that require permanent disposal. Therefore, even if reprocessing and recycling were adopted,

permanent disposal almost surely will be necessary for some portion of the commercial spent fuel inventory.

Based on its review, the Commission expresses confidence that many geologic formations and sites in the United States would be technically suitable for a repository. In addition, it recommends further research and development to help resolve some of the uncertainties associated with deep borehole disposal (BRC, 2012, p. 30).

Timely Development of Consolidated Storage Facilities

In the fifth central recommendation, the Commission calls: (a) for the United States to “establish a program that leads to the timely development of one or more consolidated storage facilities”; and (b) for “vigorous, ongoing efforts by industry and by the appropriate regulatory authorities to ensure that all near-term forms of storage meet high standards of safety and security for the multiple-decade-long periods they are likely to be in use” (BRC, 2012, p. 32).

The horrific accident at the Fukushima Daiichi nuclear power plant on March 11, 2011 (about midway through the BRC’s efforts) called America’s attention to the thousands of tons of spent fuel currently stored at reactor sites across the country and to the fact that we do not have any place else to put it.

Storage of spent fuel for some period of time after it has been removed from the reactor is unavoidable. In the early days of the nuclear enterprise, it was assumed that the storage period would last no longer than a decade, or possibly two, after which the spent fuel would be shipped off for reprocessing or disposal. Neither has happened. Spent fuel is, and will continue to be, stored at reactor sites in much larger quantities and for much longer periods of time than had been anticipated.

About 75 percent of spent fuel is stored in pools, and 25 percent is stored in dry casks. Fortunately, experience in the United States indicates that storage either at or away from sites where the waste was generated can be implemented safely and cost effectively. Nevertheless, ensuring safe and secure storage for the decades-long periods now contemplated “will require continued public and private efforts... to conduct rigorous research and oversight and continuously incorporate lessons learned from new developments or events” (BRC, 2012, p. 34).

In the Commission’s view, we need consolidated spent fuel storage facilities, which would: (1) facilitate

the removal of “stranded” spent fuel from the sites of shutdown reactors; (2) enable the federal government to begin meeting its waste-acceptance obligations independent of the schedule for operating a permanent repository; (3) provide flexibility in responding to lessons learned from Fukushima and other events; (4) provide the flexibility needed to support an adaptive, phased approach to repository development; and (5) offer opportunities for cost-effective R&D on, and experience with, spent fuel handling and storage (BRC, 2012, pp. 35–39). For these reasons, and because progress in consolidated storage could be crucial to the success of a revitalized nuclear waste program, the Commission urges prompt efforts to develop consolidated storage facilities.

Transport of Spent Nuclear Fuel and High-Level Waste

The Commission’s sixth recommendation calls for “prompt efforts to prepare for the eventual large-scale transport of spent nuclear fuel and high-level waste to consolidated storage and disposal facilities when such facilities become available” (BRC, 2012, p. vii).

Current standards and regulations governing the transport of spent nuclear fuel and high-level waste have, in the view of the Commission, “functioned well,” and the safety record has been “excellent” (BRC, 2012, p. 81). But the familiar caveat regarding financial investment, that past performance is no guarantee of future success, also applies to the future transport of nuclear materials, especially because the number of shipments will increase markedly when consolidated storage facilities and disposal facilities become operational. And these greater transport demands are likely to heighten public concerns about safety, security, and environmental impact.

Although existing standards and regulations have served admirably, changes will be needed to address new challenges. For example, the NRC has not yet granted a license for the transport of the higher burnup fuels that are now commonly discharged from reactors. In addition, spent fuel that may have degraded after extended storage may present new obstacles to safe transport.

Experience with transportation issues associated with WIPP and other nuclear facilities shows that planning, development, and production of specialized equipment, training, and other preparations for nuclear transport involve many different parties and take a substantial amount of time. Hence the Commission’s call for prompt efforts to prepare to meet future transport needs.

State, tribal, and local officials should be extensively involved in these preparations and should be provided with the resources necessary to meet their responsibilities in this area.

When consolidated storage facilities and disposal facilities become available, the increase in transport demand is likely to heighten public concerns about safety, security, and environmental impacts.

Support for Innovation and Workforce Development

The Commission’s seventh recommendation calls for “support for continued U.S. innovation in nuclear energy and for workforce development” (BRC, 2012, p. vii).

A forward-looking strategy for managing the back end of the nuclear fuel cycle must look beyond current technologies. The Commission “puts a premium on creating and preserving options that could be employed by future generations to respond to the particular circumstances they face. RD&D [research, development, and demonstration] is key to maximizing those options” (BRC, 2012, p. 99).

Based on its review of “the most authoritative available information on advanced reactor and fuel cycle technologies,” the Commission came to the following conclusion (BRC, 2012, pp.100, 101):

We concluded that while new reactor and fuel cycle technologies may hold promise for achieving substantial benefits in terms of broadly held safety, economic, environmental, and energy security goals and therefore merit continued public and private R&D investment, *no currently available or reasonably foreseeable reactor and fuel cycle technology developments—including advances in reprocessing and recycling technologies—have the potential to fundamentally alter the waste management challenge this nation confronts over at least the next several decades, if not longer.*

and

As a group we concluded that it is premature at this point for the United States to commit irreversibly to any particular fuel cycle as a matter of government policy...

Even if the United States chooses at some point to close the nuclear fuel cycle, the need for consolidated storage and deep geologic disposal will remain.

In the near term, RD&D could lead to improvements in the safety and performance of light-water reactors and associated fuel cycle activities. In the longer term, “game-changing” innovations (e.g., small modular reactors, high-temperature reactors, and fast-spectrum reactors) might lead to very large benefits. In conjunction with these RD&D activities, the Commission supports expansion of the NRC’s efforts to develop a regulatory framework for advanced nuclear energy systems and to lower barriers to commercial investment (BRC, 2012, pp. 106–108).

To ensure that an appropriately educated and trained nuclear workforce is available in the future, the Commission recommends “expanded federal, joint labor-management and university-based support for advanced science, technology, engineering, and mathematics training to develop the skilled workforce needed to support an effective waste management program as well as a viable domestic nuclear industry” (BRC, 2012, p. 108).

Active International Leadership

The Commission’s eighth key recommendation calls for “[A]ctive U.S. leadership in international efforts to address safety, waste management, non-proliferation, and security concerns” (BRC, 2012, p. vii).

Nuclear safety is a global concern. A nuclear accident anywhere affects nuclear programs everywhere. Thus, our nation’s ability to maintain or expand its nuclear power enterprise will depend to a large extent on safety performance in other countries, some of which may need help to achieve high safety standards. Consequently, the Commission recommends that “the United States work with the International Atomic Energy Agency (IAEA) and other interested nations to launch a major international effort . . . to enable the safe application of nuclear waste in all countries that pursue this technology” (BRC, 2012, p. 111).

Minimizing the proliferation of nuclear weapons is a longstanding, principal American goal. In support of this goal, the Commission urges continued U.S. support for the IAEA’s work on physical security and safeguards technologies and, in the longer term, support for the use

of multinational nuclear fuel cycle facilities under comprehensive IAEA safeguards (BRC, 2012, p. 114). In addition, the Commission encourages U.S. acceptance of spent fuel from foreign commercial reactors in cases where the president chooses to authorize such action for national security reasons (BRC, 2012, p. 115).

The Commission recognizes that “the United States cannot exercise effective leadership on issues related to the back end of the fuel cycle so long as its own program is in disarray; effective domestic policies are needed to support America’s international agenda” (BRC, 2012, p. xiv).

Conclusion

Despite the dismal overall record of the U.S. nuclear waste program, the Commission believes that success can be achieved. Experience in the United States and abroad has shown that suitable sites for nuclear facilities can be found and can be accepted by relevant stakeholders and that the funds required for the development and operation of an effective nuclear waste program have been, are being, and will continue to be collected.

The Commission sees reasons to believe that implementation of its recommended strategy will lead to success: “We know what we have to do, we know we have to do it, and we even know how to do it.” Whether that optimism is justified will be known only “if we start, which is what we urge the Administration and Congress to do, without further delay” (BRC, 2012, p. xv).

References

- BRC (Blue Ribbon Commission on America’s Nuclear Future). 2012. Report to the Secretary of Energy. Available online at http://brc.gov/sites/default/files/documents/brc_finalreport_jan2012.pdf.
- DOE (U.S. Department of Energy). 2010. Secretary Chu Announces Blue Ribbon Commission on America’s Nuclear Future. Press Release, January 29, 2010. Washington, D.C.: DOE. Available online at <http://www.ne.doe.gov/newsroom/2010PRs/nePR012910.html>.
- Nature. 2008. U.S. election: questioning the candidates. *Nature* 455: 446–449. Available online at <http://www.nature.com/news/2008/080903/full/455446a.html>.
- White House. 2010. Presidential Memorandum—Blue Ribbon Commission on America’s Nuclear Future. Office of the Press Secretary, The White House, January 29, 2010. Available online at <http://www.whitehouse.gov/the-press-office/presidential-memorandum-blue-ribbon-commission-americas-nuclear-future>.

Regardless of how long spent fuel is stored, eventually it will have to be moved from reactor sites.

Storage of Spent Nuclear Fuel

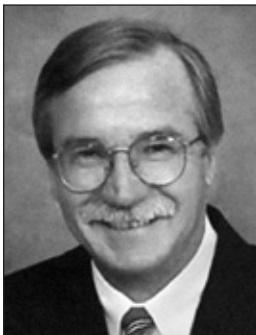

Andrew C. Kadak is Principal, Exponent Inc., Natick, Massachusetts, and a member of the U.S. Nuclear Waste Technology Review Board.¹

Andrew C. Kadak

After nuclear fuel has been used for five to six years to furnish the power to produce electricity, the spent (or used) fuel, which is still highly radioactive, must be stored on the reactor site until it can be moved to a geological disposal site. The disposal site selected in the United States was Yucca Mountain, located in a remote desert region of the Nevada Nuclear Weapons Test Site. However, after 20 years of study, a cost of \$10 billion, and the submission of a licensing application to the Nuclear Regulatory Commission (NRC), which was nearing completion of its review, President Obama directed the U.S. Department of Energy (DOE), the responsible federal agency, to cancel the project. That decision is being appealed in the courts, and the outcome is still not clear.

At the direction of the president, DOE then created the Blue Ribbon Commission on America's Nuclear Future (the BRC or the Commission) to study what to do next with regard to the disposal of nuclear waste, which is currently stored at nuclear power plant sites, either in spent fuel storage pools or in concrete-shielded canisters or dry casks. In January 2012, the Commission completed its review and delivered its final report, *Report to the Secretary of Energy* (BRC, 2012).

¹ This paper does not necessarily represent the positions of the U.S. Nuclear Waste Technology Review Board.

One of the BRC's recommendations, in the absence of a waste disposal site, was the creation of one or more centralized, "interim" (or consolidated), spent-fuel storage facilities, which would not have been necessary had the Yucca Mountain Project been opened by 2017, as planned. The Commission believes that some communities and states might be willing to accept the presence of interim storage facilities for spent nuclear fuel based on a volunteer, consensus process. However, given that there is no plan for a permanent repository and that a consensus-based process for the siting of interim storage facilities was tried in the past and failed (Kadak and Yost, 2010), the prospects for success are not high.

Lawsuits brought by utilities for breach of contract when DOE did not begin accepting spent fuel from nuclear plant sites in 1998, as required by law, have further complicated the issue. If DOE does not start accepting spent fuel until 2020, the estimated liability to U.S. taxpayers could be as high as \$20.8 billion (BRC, 2012). To date, taxpayers have paid \$2 billion to nuclear utilities to compensate them for the costs of storing spent fuel. Thus, the overall cost, so far, for canceling the Yucca Mountain Project has been more than \$12 billion, and it increases with every year of delay (BRC, 2012). For their part, nuclear utilities are anxious to have the spent fuel removed from their sites, especially in places where the reactors have been decommissioned, leaving only spent fuel storage pools or casks on the site.

The purpose of this article is to describe the current status of spent fuel storage and the challenges associated with interim storage of unknown duration at existing nuclear plant sites.

What is Spent (Used) Fuel?

In the course of generating electricity, nuclear plants create small amounts of highly radioactive waste in the form of spent nuclear fuel, which constitutes a significant hazard to human safety if not properly stored and disposed. Because of the radioactivity and extreme longevity of spent nuclear fuel, its management is a major policy challenge for virtually every country in the world that generates nuclear power. According to the National Academy of Sciences (National Research Council, 1990), the best way to dispose of nuclear waste is in a geologic repository. This is also the common conclusion of all nations with nuclear power plants.

Two types of nuclear reactors are used in the United States, pressurized-water reactors and boiling-water

reactors, to generate steam to power the turbines and electric generators that produce electricity. Fuel rods comprise the "used fuel" that is stored at reactor sites in used-fuel storage pools and in dry storage systems. Figure 1 shows typical fuel-rod assemblies for pressurized and boiling-water-reactors.

Characteristics of Spent Nuclear Fuel

Spent nuclear fuel has the following characteristics:

- Small volume and mass. The energy released from nuclear reactions is about one million times greater than from the burning of fossil fuels; consequently, only small quantities of spent nuclear fuel are generated.
- Fuel value. Existing reactors recover slightly less than 1 percent of the energy value of the initial mined uranium. Advanced breeder reactors could recover most of the energy value of the uranium by appropriate recycling of the spent fuel and the use of depleted uranium from the uranium enrichment process. Although

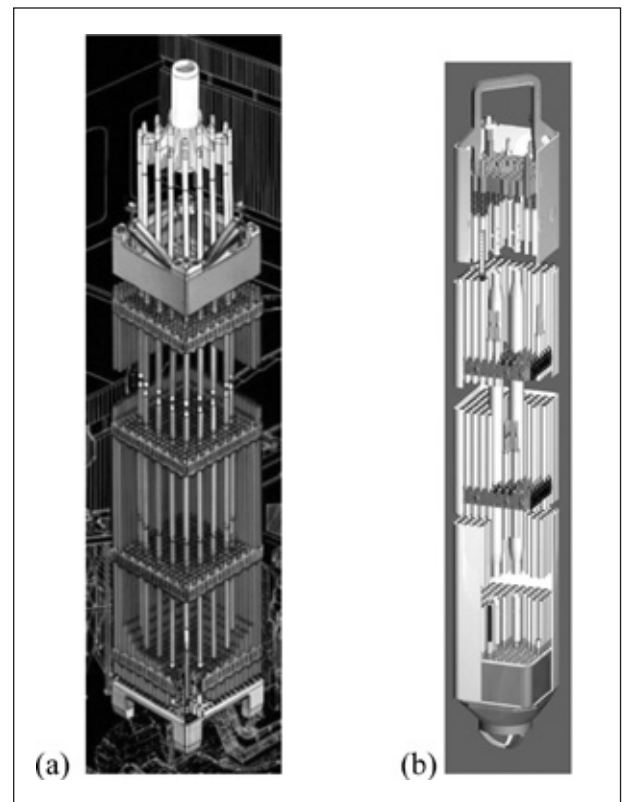

FIGURE 1 Typical spent-fuel assemblies for (a) a pressurized water reactor and (b) a boiling-water reactor. Source: (a) Courtesy Westinghouse and (b) http://gepower.com/prod_serv/products/nuclear_energy/en/downloads/gnf2_adv_poster.pdf.

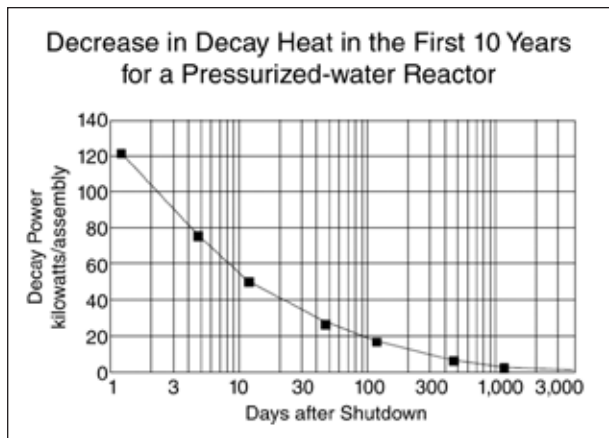

FIGURE 2 Typical decay heat curve for spent fuel from a pressurized-water reactor. Source: Adapted from MIT 22.06 Course Material Open Courseware.

recycling spent fuel is not economical today, this may change in the future.

- **Radioactive decay.** As radioactive materials decay to non-radioactive materials, they generate heat. Over time, both radioactivity and heat generation from spent fuel decrease. Therefore, the longer spent fuel is stored on reactor sites, the less complex the design of a permanent (or interim) repository can be, because the heat load, which is a limiting design constraint, will be much lower. Figure 2 shows the reduction in decay heat over time.

Options for Spent Fuel Storage

Two options are available for storing spent fuel—wet storage in pools of water and dry storage in canisters or casks. However, for the first five years after discharge from a reactor, spent fuel assemblies generate too much heat to be safely stored in dry canisters or casks. During those years, they require active cooling in storage pools to prevent damage to the fuel. The two options are briefly described below.

Wet Storage. Spent-fuel pools are 40-foot deep, water-filled, and typically lined with stainless steel. Submerged holding racks are capable of safely storing spent-fuel assemblies after they have been removed from a reactor (Figure 3). The water and the concrete sides and floor of the pool shield reactor workers from radiation from the spent fuel, and pumps actively remove decay heat generated from the fuel-rod assemblies.

When the current generation of reactors was being built, fuel storage pools were intended to provide only short-term cooling until the assemblies could be sent

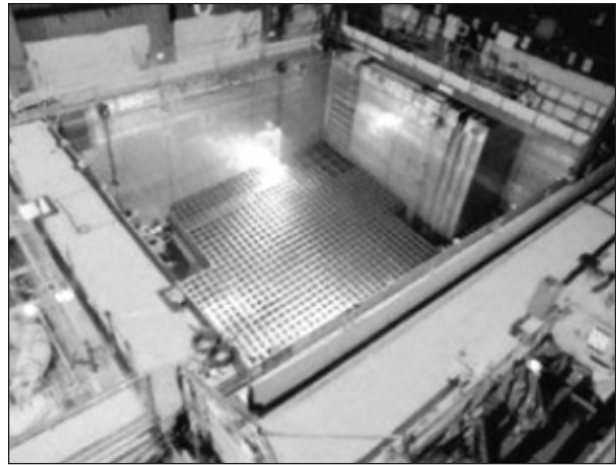

FIGURE 3 Wet storage system—spent fuel pool. Source: NRC, 2012.

to a storage or reprocessing site. As a result, storage pools were constructed with only a small storage capacity (typically enough for about one-and-one-third of the assemblies in a core). However, the ban on reprocessing spent fuel in the 1970s and the failure to build a national repository by 1998 made storage in spent-fuel pools the de facto policy of the United States.

In response, reactor operators were forced to retrofit their storage pools in an effort to increase their capacity. By using more densely packed storage racks and adding neutron absorbers, utilities were able to expand their waste-storage potential. Ultimately, however, the pools became filled to capacity even with more densely packed storage racks. To make room for more spent fuel and enable the plants to keep operations going, the storage racks had to be moved to dry storage systems.

Since 1986, more and more fuel storage pools have approached their maximum holding capacity (Figure 4). By 2017, all but one site (which was constructed with sufficient pool storage capacity to accommodate all of the spent fuel produced during the reactor's lifetime) will be at capacity, necessitating the greater use of dry storage.

Dry Storage. By the end of 2011, the United States commercial nuclear waste inventory had reached approximately 65,000 metric tons of heavy metal (MTHM). This represents about 224,000 fuel assemblies. Roughly 50,000 MTHM are held in spent fuel pools. The remaining 15,000 MTHM have been placed in casks that are collectively referred to as “dry storage.” Roughly 2,200 MTHM are produced each year by existing nuclear reactors.

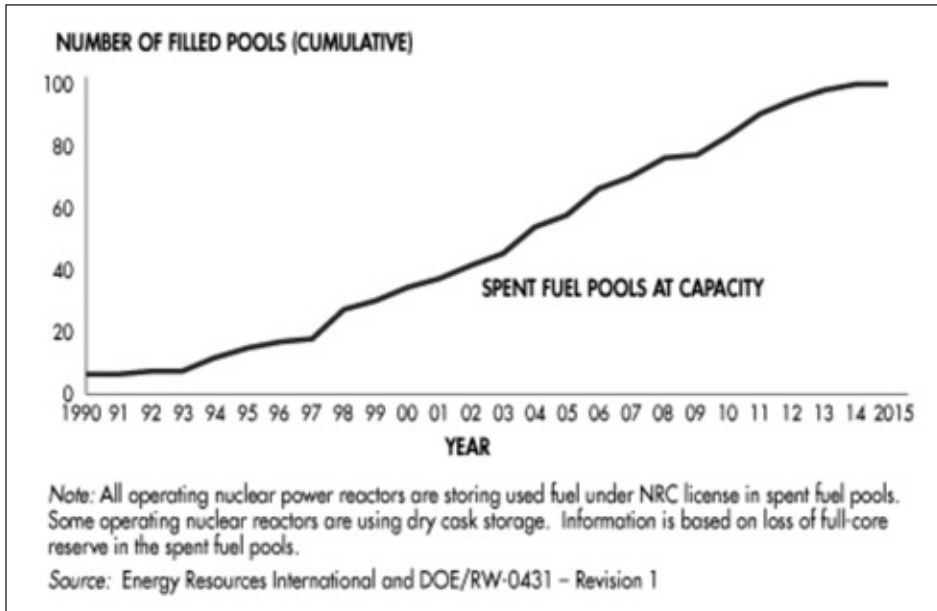

FIGURE 4 Status of filled spent fuel pools. Source: Energy Resources International and DOE/RW-0431 – Revision 1.

In the early 1980s, in response to the overcrowding of storage pools, the nuclear industry began to explore other temporary storage techniques. Spent fuel assemblies that have decayed sufficiently, thereby emitting less heat, can be transferred to dry storage systems consisting either of thick-walled metal casks bolted closed with metallic seals or thin-walled canisters surrounded by a metal or concrete outer shell for shielding. Both casks and canisters are passively cooled by ambient air. To date, utilities have transferred 13,000 MTHM of spent fuel to above-ground dry storage systems.

Spent fuel canisters are filled with inert helium gas to prevent degradation by oxidation. They are then seal welded and placed in concrete cylinders fitted with inner metal liners (which provide radiation shielding) or in separate metal enclosures.

Canisters loaded with spent fuel are moved to dry-storage facilities, referred to as independent spent fuel storage installations (ISFSIs) on the utilities' sites. ISFSIs are large, parking-lot-type concrete pads surrounded by protective fencing and under continuous security surveillance.

Typical storage casks can be stored in either vertical or horizontal systems (Figures 5, 6, and 7). Cask systems are popular among reactor operators because of their inherent flexibility. For one thing, they allow for the modular expansion of storage capabilities. For another, licensed “dual-purpose” casks can be used for both storage and transportation of nuclear waste. Some cask

vendors have even developed “multiple-purpose containers” they hope will be suitable for storage, transport, and disposal.

Storage-only casks, which are not suitable for transportation, require repackaging prior to shipment. The easiest way to do this is by first placing the casks back into spent fuel pools and transferring the spent fuel from the storage-only canister into a canister suitable for transportation. However, this is not always possible, because some plants, including the spent

fuel storage pools, have been decommissioned. Therefore, either alternative dry transfer systems will have to be developed or NRC will have to grant special exemptions for spent fuel in storage-only canisters.

Dry-storage systems for spent fuel (i.e., ISFSIs) are licensed by NRC according to Title 10, Part 72 of the Code of Federal Regulations (10 CFR 72) (Federal Register, 2009; NRC, 2008). Approximately 22 percent of domestic spent fuel is in dry storage at 44 plant sites. Figure 8 shows existing and likely future locations for storage of commercial spent nuclear fuel.

Dry cask storage of nuclear waste is considered safe. NRC estimates that the per-cask risk of failure-induced fatalities is equal to 1.8×10^{-12} in the first year of operation and 3.2×10^{-14} per year for each subsequent year of storage (NRC, 2007).

Under current regulations, NRC licenses commercial dry-storage systems initially for 20 years. However, NRC recently authorized an exemption to the regulation and renewed the license for a dry-storage system at the Surry Nuclear Power Station in Virginia for an additional 40 years (a total of 60 years). On September 15, 2009, NRC proposed changing the initial licensing and license renewal periods from 20 to 40 years (Federal Register, 2009).

Centralized Interim Storage

The siting of a centralized regional interim storage facility will be more difficult today than in the past, because we have no clear exit strategy for the spent fuel

that is “temporarily” stored. Under the Nuclear Waste Policy Act (NWPA), as amended in 1987, Congress authorized volunteer efforts by a “nuclear waste negotiator” to site a monitored, retrievable, interim storage facility (NWPA, 1983, 1987). The effort failed, however, partly because of political opposition and partly because of congressional interference in the process once siting decisions were near.

Despite the BRC’s optimism, there are no indications of fundamental changes in the politics of siting interim facilities or in the willingness of states and local communities to accept such a facility. Some have suggested that co-locating a reprocessing plant and an interim storage facility, which would provide jobs and an economic boost to the area, might be a differentiator. But that remains to be seen.

The NWPA, as amended in 1987, forbids DOE from building an interim waste storage facility until Yucca Mountain obtains an operating license (NWPA, 1987). This legislative restriction will have to be removed to allow the construction of an interim facility independent of progress on a repository site. Of course, this would make the siting of an “interim” facility even more difficult.

Efforts by private utilities to build a regional interim storage facility, such as the private fuel storage (PFS) project in Utah, which, after a 10-year licensing process, was granted an NRC license, have been stymied by national and state political opposition. Nevertheless, because the PFS site already has an NRC license, it should be considered a near-term option.

Even if another volunteer site could be found, the licensing process for that site could also last 10 years, plus 3 to 5 years for construction, before any spent fuel could be accepted by the facility. In addition, a transportation infrastructure would have to be constructed for shipping casks of spent fuel to the facility. The process could be expedited if construction and permits could be pursued concurrently.

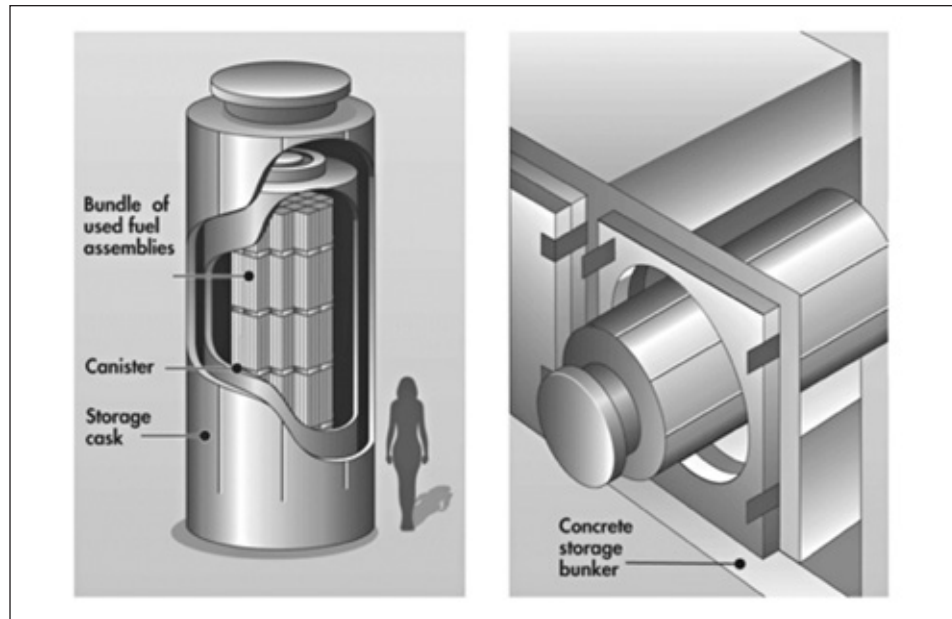

FIGURE 5 Dry cask storage system: vertical on left, horizontal on right. Source: NRC, 2012.



FIGURE 6 Independent spent fuel storage installation (ISFSI). Used with permission of NAC International, Inc.

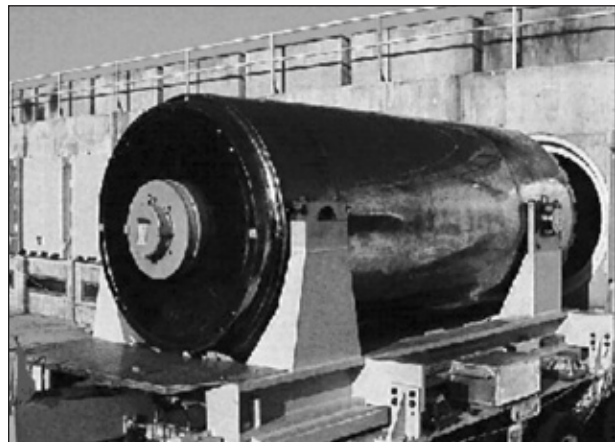

FIGURE 7 Independent spent fuel storage installation (ISFSI) with horizontal dry cask storage. Source: Pacific Nuclear, Nuclartourist.com.

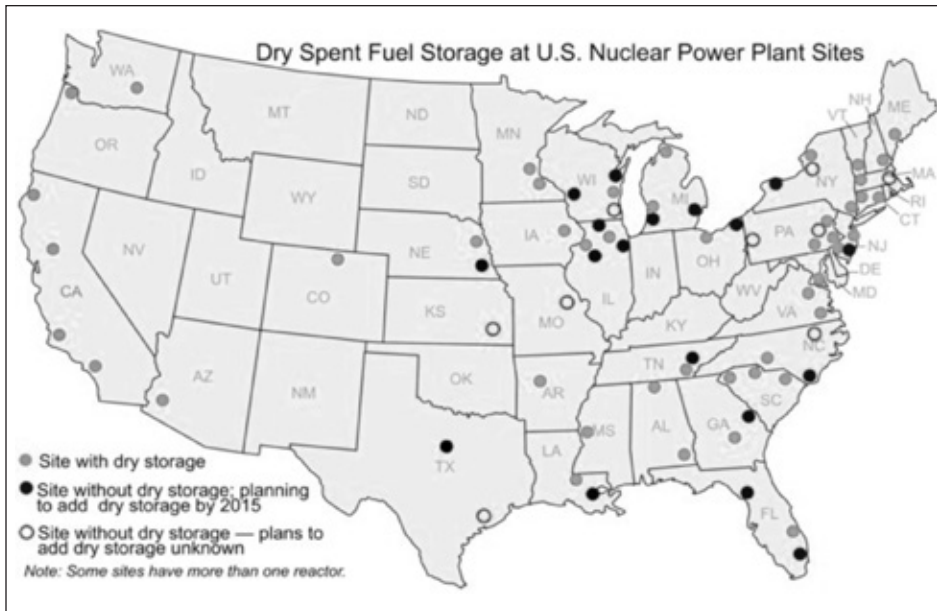

FIGURE 8 Commercial dry used-fuel storage facilities. Source: NRC, 2012.

Another option would be to site an interim facility on land at an existing federal facility that already has the requisite security and infrastructure. DOE, for example, operates many national laboratories, and the military has many bases across the country that might meet these requirements.

In December 2008, DOE issued a report to Congress on the regulatory issues associated with the creation of a large, independent site for centralized interim storage and concluded that it would take six years to complete such a facility—three years for licensing and three years for construction (DOE, 2008). Thus, 2015 is the earliest date that operations could begin. However, given that the PFS facility took more than 10 years to obtain a license and fight its way through legal battles, DOE's estimates are considered optimistic. If an existing site were used, operations might begin sooner, but significant political and regulatory issues would have to be resolved.

Taxpayer Obligation

To cover the costs utilities have incurred in building their own dry cask storage facilities, nuclear utilities have been paying 0.1 cent per kilowatt-hour for electricity generated by nuclear plants. By the end of 2010, \$16 billion had been collected (BRC, 2012). When interest is added and expenditures are subtracted, a balance of \$27 billion remains to fund repository development.

Even though this money does not really exist, because it has been used to help fund the federal government,

and even though DOE did not, as mandated by law and by contract, open the high-level waste repository by 1998, the taxpayer obligation for utilities remains. By 2020, this obligation is estimated to total \$20.8 billion. By that time, most utilities will have built their own ISFSIs, for which the government will have to pay under court decisions. Thus, the total liability to the government from the unspent, but unavailable, fund and payments to utilities for failing to remove spent fuel from reactor sites comes to \$49.1 billion (BRC, 2012).

Decommissioned Nuclear Plant Sites (Orphaned Waste)

Currently, 104 commercial nuclear reactors are operating in the United States, and 14 have been permanently shut down. Of the 14 facilities that have been shut down, 4 are located at sites with other operating reactors. The other 10 decommissioned reactors are located at 9 sites that have no operating reactors; and all 9 of them have stranded spent fuel stored on site. Figure 9 shows the Yankee Atomic Nuclear Plant site with the reactor gone and the spent fuel in the background. As more reactors are shut down in the future, the number of stranded storage sites will increase considerably, raising the cost, not only for utilities, but also ultimately for U.S. taxpayers.

The marginal cost of storing spent fuel on a site with ongoing nuclear operations is relatively low, because most of the operations and maintenance costs for storage can be integrated with existing site operations with little additional overhead. However, at sites with no current nuclear operations, the cost of spent fuel storage is about \$8 million dollars per year per site (Kadak and Yost, 2010). Thus, the high cost of maintaining spent fuel on sites with no ongoing reactor operations is a primary economic incentive for consolidating spent fuel at a central facility or on sites with working reactors.

One option would be to co-locate decommissioned spent fuel at an existing decommissioned plant ISFSI

in a community willing to host spent fuel from other plants. The chances of success would depend on the willingness of the community and state to accept such a solution. In addition, this might be a near-term test case for finding volunteer sites in communities that understand the issues related to spent fuel storage and past nuclear operations.

Transportation

Regardless of how long spent fuel is stored, it will eventually have to be moved from the reactor sites either to offsite interim storage facilities, to used fuel processing facilities for recycling, or to a waste disposal site. Transportation regulations are largely focused on the integrity of the casks that contain the used fuel. These casks are designed to withstand a series of accidents without releasing radioactive materials.

Figure 10 shows a full-scale crash test conducted by Sandia National Laboratories in 1977. In this test, a locomotive traveling at approximately 80 miles per hour crashed broadside into a used fuel transportation cask. As Figure 10 shows, the cask and the dummy fuel inside it performed in accordance with regulatory requirements.

Economics

The most recent capital-cost estimate for a centralized ISFSI of 40,000 MTHM is about \$560 million; this includes design, licensing, and construction of the storage pad, cask-handling systems, and rail infrastructure (locomotive, rail cars, transport casks, etc.) (EPRI,

Independent Spent Fuel Storage Installation



FIGURE 9 Decommissioned Yankee Atomic Electric Company site with ISFSI. Source: Yankee Atomic Electric Company.



FIGURE 10 Spent fuel crash test performed in 1977. A locomotive traveling at approximately 80 miles per hour crashed broadside into a used fuel transportation cask. The cask and the dummy fuel inside it performed in accordance with regulatory requirements. Source: <http://www.sandia.gov/recordsmgmt/ctb1.html>.

2009). Annual operating costs during loading are estimated at \$290 million per year, including the costs of dual-purpose canisters and storage overpacks, which will provide shielding for the canisters once they are placed on the interim storage pads.

It will take 20 years to fully load an ISFSI of this size, and a period of “unloading” and eventual decommissioning will be necessary after storage. The interim period of “caretaking” is estimated to cost about \$4 million per year, about half the caretaking costs of a decommissioned reactor (Kadak and Yost, 2010).

Technical Basis for Long-Term Storage

The length of time an interim storage facility will be used cannot be known, because there is no firm plan to build a repository or reprocessing plant. However, some have suggested that it could be as long as 300 years. Given that it might be a very long time, the U.S. Nuclear Waste Technology Review Board (NWTRB) was asked to assess the technology basis for long-term storage.

Based on its assessment, the study board concluded that the technical basis for the spent fuel currently being discharged (high utilization, burnup fuels) is not well established and that the possibility of degradation mechanisms, such as hydriding, will require more study. The NWTRB recommended periodic examinations of representative amounts of spent fuel to ensure that degradation mechanisms are not in evidence and to confirm the presence of the helium cover gas (NWTRB, 2010). The industry and DOE have embarked on a research program to address these issues (EPRI, 2010).

Conclusions

As a result of political decisions, spent fuel in the United States will have to be stored either at reactor sites or in regional interim storage facilities. Given the political difficulties of finding a state and community willing to host either an interim storage facility or a waste repository, predictions of success or timing cannot be made. Here is what we do know:

1. Storage at reactor sites will be necessary for a minimum of 10 more years.
2. According to NRC, spent fuel can be safely stored in dry casks for at least 60 years, and evidence may show that it can be stored for even longer.
3. Building an interim storage facility is currently not permitted by law. Therefore, legislative action will be necessary before such a storage facility can be considered.
4. Once an interim facility has been identified and licensed, transportation to the site will require considerable additional time and investment.
5. Until DOE removes the spent fuel from operating and decommissioned sites, the cost to taxpayers for the government's failure to build a repository will continue to grow.
6. The top priority for ending this costly financial obligation completely is to remove spent fuel from decommissioned sites. The obligation would

continue for operating sites, however, until DOE removes all of the spent fuel, as obligated by contracts with utilities.

References

- BRC (Blue Ribbon Commission on America's Nuclear Future). 2012. Report to the Secretary of Energy. Available online at http://brc.gov/sites/default/files/documents/brc_finalreport_jan2012.pdf.
- DOE (U.S. Department of Energy). 2008. Report to Congress on the Demonstration of the Interim Storage of Spent Nuclear Fuel from Decommissioned Nuclear Power Reactor Sites. Available online at <http://pbdupws.nrc.gov/docs/ML0834/ML083450160.pdf>.
- EPRI (Electric Power Research Institute). 2009. Cost Estimate for an Away-From-Reactor Generic Interim Storage Facility (GISF) for Spent Nuclear Fuel. Technical Update 1018722. May 2009. Palo Alto, Calif.: EPRI.
- EPRI. 2010. Used Fuel and High-Level Radioactive Waste Extended Storage Collaboration Program. November 2009 Workshop Proceedings. Palo Alto, Calif.: EPRI.
- Federal Register. 2009. 10 CFR Part 72 License and Certificate of Compliance Terms. 74FR47126. September 15, 2009.
- Kadak, A.C, and K. Yost. 2010. Key Issues Associated with Interim Storage of Used Nuclear Fuel. MIT-NFC-TR-123. December. Cambridge, Mass.: Massachusetts Institute of Technology.
- National Research Council. 1990. Rethinking High-Level Radioactive Waste Disposal: A Position Statement of the Board on Radioactive Waste Management. Washington, D.C.: National Academy Press.
- NRC (U.S. Nuclear Regulatory Commission). 2007. A Pilot Probabilistic Risk Assessment of a Dry Cask System at a Nuclear Power Plant. NUREG-1864. Available online at <http://www.nrc.gov/reading-rm/doc-collections/nuregs/staff/sr1864/sr1864.pdf>.
- NRC. 2008. Title 10, Code of Federal Regulations, Part 72, Energy: Licensing Requirements for the Independent Storage of Spent Nuclear Fuel and High-Level Radioactive Waste, and Reactor-Related Greater than Class C Waste. Washington, D.C.: U.S. Government Printing Office. Office of Federal Register National Archives and Records Administration, as amended June 9, 2008 (10 CFR 72).
- NRC. 2012. Locations of Independent Spent Fuel Storage Installations. Available online at <http://www.nrc.gov/waste/spent-fuel-storage/locations.html>.
- NWPA (Nuclear Waste Policy Act). 1983. Nuclear Waste Policy Act of 1982, 42 U.S.C. 10101, P.L. 97-425; Nuclear

- Waste Policy Act Amendments of 1987. Available online at <http://epw.senate.gov/nwpa82.pdf>.
- NWPA (Nuclear Waste Policy Act as Amended) 1987. P.L. 100-203-December 22, 1987, Part E: Nuclear Waste Technical Review Board. Available online at <http://www.nwtrb.gov/mission/1987aa.pdf>.
- NWTRB (Nuclear Waste Technology Review Board). 2010. Evaluation of the Technical Basis for Extended Dry Storage and Transportation of Used Nuclear Fuel. December. Available online at http://www.nwtrb.gov/reports/eds_rpt.pdf.

The Nuclear Regulatory Commission must balance its preparations for policy changes with the safe, secure operation of existing facilities, the availability of resources, and the constraints of current law.

Emerging Regulatory Challenges in the Management of Spent Nuclear Fuel and High-Level Radioactive Waste



James Rubenstone is chief of the Science and Technology Branch, Division of Spent Fuel Alternative Strategies, Office of Nuclear Material Safety and Safeguards, U.S. Nuclear Regulatory Commission.

James Rubenstone

Under the current structure for the management of commercial spent nuclear fuel (SNF)¹ in the United States, the licensee is responsible for its safe and secure storage and transportation. The U.S. Nuclear Regulatory Commission (NRC) ensures safety and security through licensing and regulatory oversight. NRC also has regulatory authority over the disposal of SNF and other types of high-level radioactive waste (HLW)² in a geologic repository.

NRC's authority to regulate SNF and HLW derives from federal law, including the Atomic Energy Act of 1954, the Energy Reorganization Act of 1974, and the Nuclear Waste Policy Act of 1982, as amended in 1987. NRC implements its regulatory authority through regulation, guidance, inspection, orders, enforcement, and other oversight actions.

Because of recent policy decisions, the U.S. program for future management of SNF and other HLW is undergoing a transition. Until a new national policy emerges, NRC is continuing to carry out its primary mission

¹ NRC uses the term "spent nuclear fuel" (SNF) to refer to irradiated reactor fuel that has been removed from service and has not been chemically separated. Some other groups use the term "used fuel" when referring to the same material.

² The term "high-level radioactive waste" (HLW), as used by NRC, covers a broader category than SNF. HLW includes highly radioactive material that results from spent fuel reprocessing, as well as other materials with enough long-lived radioactivity to require permanent isolation. Distinctions among the details and history of radioactive waste classification are not addressed in this article.

of ensuring the “safe use of radioactive materials for beneficial civilian purposes while protecting people and the environment.” At the same time, NRC staff is working to prepare itself to fulfill its role in the new national policy for managing SNF and other HLWs, specifically in the areas of licensing and regulation of the back end of the nuclear fuel cycle.

Current Regulatory Framework

Most commercial SNF in the United States is owned by the utility that produced it and is stored—either underwater in spent fuel pools or in dry-cask systems—on the sites of operating and decommissioned nuclear power plants. NRC regulation of wet storage at nuclear power plant sites falls within the operating license for each reactor issued under the regulations in Title 10 of the U.S. Code of Federal Regulations (CFR) Part 50.

Most reactor facilities were not designed to store the full amount of SNF that the reactor generates over its operational life. Therefore, as pools reach their storage capacity, the power plants generally move SNF into dry storage, usually on site. Dry storage facilities, on sites of active and decommissioned nuclear power plants, are referred to as independent spent fuel storage installations (ISFSIs) and are licensed under 10 CFR Part 72.

Regulating Storage Systems

The regulations in 10 CFR Part 72 apply to both facilities where SNF is stored and the certification of the cask systems used for dry storage. Licenses and certificates are issued for fixed terms and can be renewed for additional fixed terms. Most existing ISFSIs were licensed for an initial period of 20 years. NRC has recently revised 10 CFR Part 72 so that the initial and renewal licenses may now be issued for terms of up to 40 years.

The regulations in 10 CFR Part 72 do not limit the number of renewals of an ISFSI license or storage system certificates. Aging management³ for SNF must include potential degradation processes and other effects of aging, as well as maintenance, inspection, and monitoring, all of which are important factors in license-renewal decisions.

Dry storage systems consist basically of stainless steel inner canisters with concrete and steel outer structures. Intact SNF assemblies are loaded directly into

inner canisters, under water in the spent fuel pool. Assemblies identified as damaged (a small fraction of the total) are loaded in specially designed damaged-fuel cans that provide additional containment. Canisters are subsequently dried, backfilled with inert gas, and sealed, either by welding or with bolted metal-seal lids. Licensed designs include both integrated and modular systems with horizontal or vertical orientations.

About 20 different dry storage system designs (including variations) from three principal vendors have been certified by NRC and are in use in the United States (NRC, 2011a). Dry storage systems are designed and built by vendors following design criteria in 10 CFR Part 72 to perform specific safety functions, including confinement of radioactive material, radiation shielding, control of criticality, removal of decay heat, and maintenance of structural integrity. The design criteria also address maintaining the retrievability capability of SNF in storage (10 CFR 72.122(1)). Staff guidance describes retrievability as the ability to handle individual or canned⁴ spent fuel assemblies by normal means (NRC, 2010a).

About 20 different dry storage system designs from three principal vendors have been certified by NRC for use in the United States.

Regulating Transport

NRC’s principal role in regulating transportation of SNF and HLW is through certification of transportation packages, as provided in 10 CFR Part 71. Shipments of radioactive and other hazardous materials are also subject to regulation by the U.S. Department of Transportation.

Criteria for SNF transportation casks include similar safety functions as for storage. Transportation casks are further evaluated for performance under severe accident conditions (such as impacts, fires, and full immersion in water). Both truck and rail casks for

³ “Aging management” refers to all actions that address the effects of aging, including prevention, mitigation, and monitoring.

⁴ “Canned” assemblies are those that have been placed in damaged-fuel cans prior to dry storage.

transporting SNF have been certified by NRC, including some dual-certified storage-transportation designs. NRC has published a number of technical reports and public information documents on the safety of SNF transportation (e.g., NRC, 1977, 2003a, 2012a; Sprung et al., 2000).

Security Requirements

Security requirements for SNF storage and transportation include both physical protection (10 CFR Part 73) and material control and accounting (10 CFR Part 74). NRC is currently revising 10 CFR Part 73 requirements that pertain to storage of SNF (NRC, 2009). Any additional revisions to security regulations that may be needed to address extended storage and transportation will be considered when the current rulemaking for 10 CFR Part 73 is complete, or as new needs for storage and disposal are identified.

Regulating Disposal

NRC has regulatory authority over the disposal of commercial SNF and HLW. Currently two sets of NRC regulations apply to this area. Disposal of SNF and HLW in geologic repositories, in a generic sense, is governed by 10 CFR Part 60. Regulations specific to geologic disposal in a repository at Yucca Mountain, Nevada, are in 10 CFR Part 63. In each case, the NRC regulation implements standards set by the Environmental Protection Agency (EPA). Although these two sets of NRC regulations and EPA standards have some common features, they also differ in several respects.

Nearly one-third of spent fuel is in dry storage at 63 licensed sites, and almost all of it is owned by the utilities that produced it.

The generic HLW disposal regulations in 10 CFR Part 60, first issued in 1983, implement EPA standards in 40 CFR Part 191. These regulations and standards provide for the evaluation of the long-term performance of a repository, after permanent closure of the facility, against a cumulative release standard, an individual protection

dose standard, and a groundwater protection standard. The regulations in Part 60 implement the EPA release standard, in part through criteria for release by various subsystem components of the barrier system (e.g., waste package, groundwater path). NRC has not applied 10 CFR Part 60 to any disposal facility, as national policy has focused on a single site for a repository.

The regulations in 10 CFR Part 63 involve a more risk-informed, performance-based approach to evaluating a geologic repository. These regulations specify an explicit role for performance assessment models in demonstrating compliance and include requirements for such models. The regulations in Part 63 implement EPA standards in 40 CFR Part 197 for post-closure performance, which address individual protection, human intrusion, and groundwater protection, but do not include a cumulative release standard for post-closure.

NRC staff's review plan for applying Part 63 (NRC, 2003b) provides further guidance on the regulatory requirements. NRC staff experience in using this regulation and guidance is captured in one volume of a safety evaluation report for the Yucca Mountain license application (NRC, 2010b) and three technical evaluation reports (NRC, 2011b,c,d).

In issuing 10 CFR Part 63, NRC acknowledged that this more risk-informed, performance-based approach provides a better regulatory framework for geologic disposal of HLW and SNF than the approach in 10 CFR Part 60. At that time, NRC stated that the "generic Part 60 requirements will need updating if applied to sites other than Yucca Mountain" (NRC, 2001). NRC has not yet begun rulemaking to effect this update.

State of the U.S. Program

Current U.S. inventories of commercial SNF are on the order of 65,000 metric tons (heavy metal equivalent), and are increasing by ~2,000 metric tons per year from an operating fleet of 104 light-water reactors. Nearly one-third of this material is now in dry storage at 63 licensed sites (NRC, 2011a), and almost all of it is owned by the power utilities that produced it. The Nuclear Waste Policy Act requires that the federal government, through the U.S. Department of Energy (DOE), take possession and permanently dispose of SNF used for commercial power generation in the United States.

The United States does not currently have an active program for reprocessing commercial SNF to produce new reactor fuel, although some interest has been

expressed in developing commercial reprocessing. DOE has possession of the HLW generated from prior U.S. reprocessing of commercial fuel, in addition to a larger inventory of HLW from its environmental management activities at defense sites. The proposed repository at Yucca Mountain was designated to dispose of 7,000 metric tons (heavy metal equivalent) of DOE-owned HLW and spent fuel along with 63,000 metric tons of commercial SNF.

In 2009, President Obama announced that the proposed repository site at Yucca Mountain, Nevada, was “no longer considered a workable option” for disposal of SNF and HLW. The following year, DOE sought to withdraw from consideration its application to construct a repository at Yucca Mountain, which had been under review by the NRC since 2008. NRC suspended its review and licensing process in 2011, when no further funds were appropriated for this purpose. DOE and NRC actions on the Yucca Mountain proceedings have been challenged in federal court, but a decision is still pending.

In 2010, the Secretary of Energy established an advisory body to DOE, the Blue Ribbon Commission on America’s Nuclear Future (BRC), to conduct a comprehensive review of policies for managing the back end of the nuclear fuel cycle in the United States. In its final report, the BRC reaffirmed the need for geologic disposal of HLW, while acknowledging that one outcome of current U.S. policy is the expectation that SNF will have to be stored for extended periods of time (BRC, 2012).

Several of the BRC’s formal recommendations could directly affect NRC’s regulatory role. The next section focuses on how these recommendations align with NRC’s current activities and potential future plans.

The Changing Policy Environment

NRC has directed its staff to prepare for potential changes in national policy on the back end of the nuclear fuel cycle and the management of commercial SNF and HLW. It is important to note that, as an independent regulator, NRC does not develop national policy for the nuclear fuel cycle. That role clearly belongs to Congress and the Executive Branch.

Nevertheless, NRC can be prepared to respond to policy changes by adjusting its regulatory framework, in keeping with its mission to ensure the safe use of radioactive materials for beneficial civilian purposes. Of course, NRC must also balance its preparation for timely response with competing priorities for continued

safe and secure operation of existing facilities, the availability of resources, and the constraints of current law.

NRC recognized the possibility of extended storage of SNF in the recent update of its Waste Confidence Decision (NRC, 2010c). The term “waste confidence” refers to NRC’s finding of “reasonable assurance” that sufficient disposal capacity will be available for commercial SNF and HLW and that storage can be managed safely and securely, under NRC regulation, in the interim. The current Waste Confidence Decision, which includes five separate findings that support these conclusions, is embodied in NRC regulation 10 CFR 51.23 as a generic determination that temporary storage of SNF after cessation of reactor operation has no significant environmental impact. The current update (2010) of the Waste Confidence Decision made this determination for at least 60 years beyond the licensed life of reactor operation.

The current regulatory framework may need revisions to accommodate extended periods of storage and transportation of older spent fuel.

NRC staff’s efforts related to the back end of the fuel cycle are focused on extended storage and subsequent transportation of commercial SNF, geologic disposal alternatives, and assessment of potential environmental impacts of an extended Waste Confidence Decision.

Extended Storage and Transportation of Spent Nuclear Fuel

NRC staff has been looking into the possibility that the current regulatory framework will need revisions to accommodate extended periods of SNF storage and the subsequent transportation of older spent fuel. As previously noted, current storage regulations allow for multiple renewals of ISFSI licenses and cask certificates. Such renewals include reviews of aging management plans, with a focus on the degradation of system components over time. Initial staff efforts have focused

on identifying necessary technical information related to degradation processes of various components of dry storage systems.

The NRC staff is considering both the existing level of knowledge for degradation processes in storage applications and how degradation may affect the safety of both storage and subsequent transport. This work draws on previous technical evaluations of extended storage (EPRI, 2011; Hanson et al., 2012; NWTRB, 2010; Sindelar et al., 2011) and is informed by staff experience with current licensing and understanding of risk (NRC, 2007).

NRC staff is examining technical areas potentially relevant to alternative disposal options in mined geologic repositories.

The NRC staff draft report (NRC, 2012b) prioritizes the technical needs and identifies those that should be addressed first. The highest priority areas include stress corrosion cracking of stainless steel canister bodies and welds, degradation of cask bolts, and swelling or pressurization of fuel pellets and rods over time. Areas of slightly lower priority include effects of aging on fuel cladding, assembly hardware, and neutron absorbers; microbiologically influenced corrosion of canister and seal materials; and degradation of concrete structures. Depending on the initiation time and rate of progression of degradation, many of these age-related processes may not be significant until far into an extended storage period.

The NRC staff draft report also identified three high-priority areas as cross-cutting topics that affect a number of components and safety functions: more realistic thermal calculation models; the effects of residual moisture after drying; and in-service methods of monitoring storage systems and components.

Thermal evaluations for current SNF storage applications, for example, focus on the maximum temperature the fuel cladding may reach, based on models with conservative assumptions that provide upper temperature bounds. During extended storage, as decay heat

decreases, these models may over-predict temperatures both inside and on the exterior of the storage canister.

The model bias noted above may be problematic, because other degradation processes will potentially come into effect at the lower temperatures expected during extended storage. These processes include the susceptibility of stainless steel canisters to stress corrosion cracking in the presence of chloride salts and atmospheric moisture and possible low-temperature ductile-to-brittle transitions in fuel cladding. More realistic thermal models could help determine the potential impacts of these processes. NRC has begun technical work on this and several other high-priority areas to provide bases for potential changes in storage and transportation regulations and guidance over extended periods of time.

NRC staff is also monitoring work by other groups, both in the United States and worldwide, that are examining technical issues related to extended storage of SNF. For example, the Electric Power Research Institute has established the Extended Storage Collaboration Program (ESCP), which coordinates work by different organizations in the United States (including DOE and industry) and other countries on technical issues related to extended storage (EPRI, 2011).

Among other topics, ESCP has been active in early planning for a possible cask demonstration project, in which pre-characterized spent fuel assemblies would be stored for some period (10 to 15 or more years) in a well-instrumented, monitored cask. Fuel assemblies would then be removed for post-storage characterization to benchmark and verify models and expectations of fuel behavior over longer periods of time. There is particular interest in monitoring a cask containing high-burnup⁵ fuel as a complement to an earlier examination of dry-stored, low-burnup fuel (e.g., Kimball and Billone, 2002).

NRC activities related to extended storage are consistent with conclusions and recommendations of the BRC report on the likely need for SNF storage over a longer time as efforts proceed to site and develop facilities for geologic disposal. The BRC report also recommends siting and establishment of consolidated storage facilities as an interim step. Current NRC regulations allow for the licensing of privately operated, away-from-reactor storage facilities for SNF from multiple power

⁵ The term “high-burnup fuel” generally applies to spent fuel that has been irradiated in a reactor to a power output of greater than 45 gigawatt-days per metric ton of uranium.

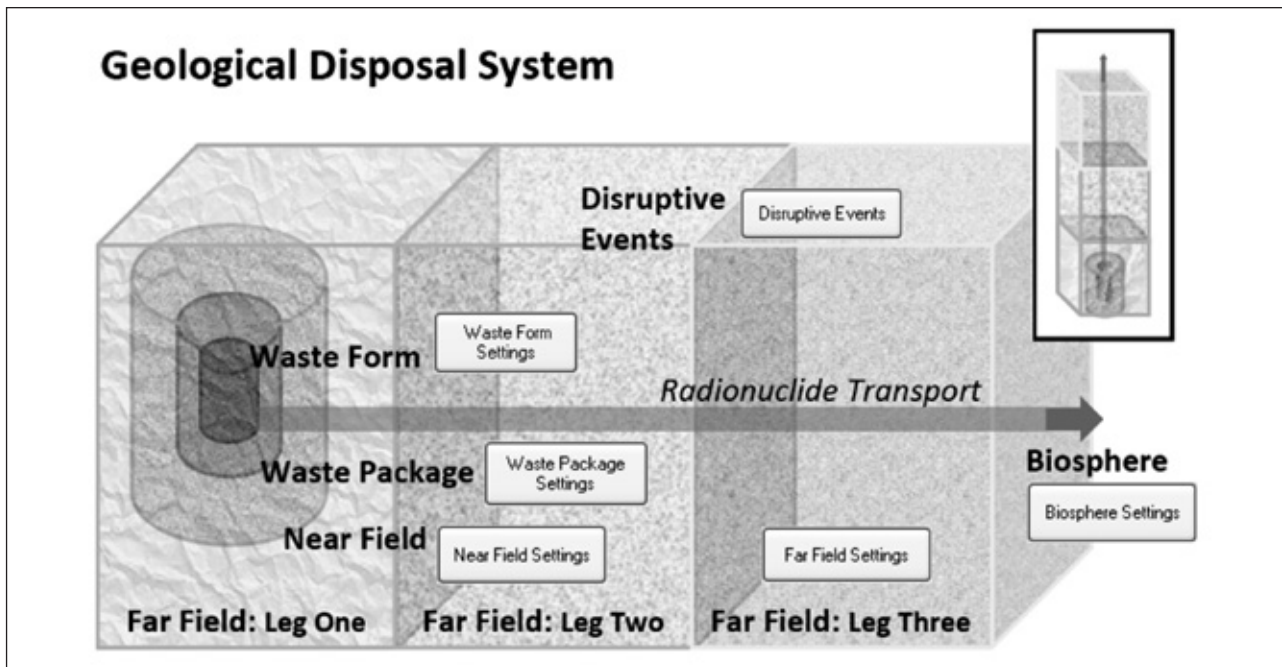

FIGURE 1 Structure of the SOAR model. Source: Adapted from Markley et al., 2011.

plants (for example, the Private Fuel Storage Facility licensed in 2006).

Geologic Disposal of Spent Nuclear Fuel and High-Level Waste

NRC has not begun formal rulemaking proceedings for revising any regulations for geologic disposal of SNF and HLW. However, NRC staff is examining technical areas potentially relevant to alternative disposal options in mined geologic repositories. To this end, the staff has developed a scoping-level assessment model to investigate how different aspects of the geologic environment and waste characteristics may affect potential repository performance.

The model, referred to as SOAR (for Scoping of Options and Analysis of Risks), is based on relatively simple or generic representations of features, events, and processes (FEPS) for a conceptual repository system. In the model, FEPS are parameterized to consider the characteristics of a variety of alternative waste forms; engineered barrier materials; and geologic, hydrologic, and geochemical settings. Uncertainties in parameters that could potentially affect radionuclide release and receptor dose can be evaluated through the stochastic sampling of parameter values.

SOAR is implemented in a visual-based software environment that allows flexibility and modular model

design (GoldSim Technology Group, 2010). A full description of SOAR can be found in the *User Guide* for version 1.0 (Markley et al., 2011).

The general structure of the SOAR model includes five principal component modules (Figure 1). The main components are Waste Form, Waste Package, Near Field environment (engineered and disturbed zones), Far Field environment (natural system), and Biosphere. A secondary component, Disruptive Events, complements the Waste Package component (which focuses mostly on failure caused by corrosion) for modeling other processes that could cause waste packages to fail (such as earthquakes).

SOAR provides insights into comparative risks for different potential repository systems. Even though its process models are relatively abstracted (i.e., necessarily simplified representations of complex processes), these insights help to focus technical work on relevant performance aspects of alternative repository designs and waste inventories. Technical investigations are designed to lay the groundwork for potential revisions of regulations for geologic disposal, as may be required by future changes in national policy.

In the BRC report, the study commission explicitly recommends that NRC begin revising 10 CFR Part 60 and engage with EPA to develop a new disposal standard to support those revisions. As previously noted,

NRC is focusing on developing technical information to support potential rulemaking but has not begun the formal rulemaking process.

The BRC report also recommends that work begin on a regulatory framework for deep borehole disposal (e.g., Arnold et al., 2011), which is beyond the scope of existing law and NRC regulations for HLW disposal and would require the development of an appropriate technical basis and rulemaking. NRC staff has done only limited work in this area thus far but is monitoring technical investigations by other groups on potential deep borehole disposal.

Potential Environmental Impacts of Future Fuel Cycle Scenarios

In conjunction with the most recent update of the Waste Confidence Decision and rule (NRC, 2010c), NRC directed its staff to conduct a comprehensive analysis of potential future impacts on the environment of extended storage and transportation in a formal Environmental Impact Statement (EIS). The staff was directed to assess the potential impacts of longer term storage of SNF to inform a possible extension by NRC of the time specified in the Waste Confidence rule.

To this end, NRC staff developed preliminary assumptions and proposed a scenario-based approach to assessing potential environmental impacts beyond the time period in the current Waste Confidence rule (NRC, 2011e). The scenarios are designed to capture credible variations in how the fuel cycle might develop and are not intended to endorse a particular position or approach. The four proposed scenarios include extended storage at different locations (on site and at one or more consolidated sites), along with possible commercial SNF reprocessing. Each scenario involves some transport of SNF and HLW as well as the handling and repackaging of SNF. All four scenarios end with disposal in a geologic repository. NRC staff is now developing relatively high-level system models for the back end of the fuel cycle to help explore the impacts of the four scenarios in the EIS.

Although the BRC report does not specifically recommend an environmental impact analysis, NRC staff efforts related to the EIS touch on several specific elements in the proposed BRC approach, including consolidated (interim) storage, preparations for large-scale transport, and potential reprocessing of SNF. Because an EIS covers a broad range of environmental impacts, NRC staff considers its efforts part of a comprehensive

approach to understanding the implications of future directions in the fuel cycle.

Conclusion

In preparation for possible changes in U.S. national policy affecting the back end of the nuclear fuel cycle in response to the BRC recommendations, NRC staff is examining the regulatory basis for extended storage, subsequent transportation, and geologic disposal of SNF and HLW. Technical investigations by NRC staff and other groups will contribute to a basis for any necessary revision to existing regulations, whether driven by new information or changes in national policy. NRC's efforts are generally consistent with the recommendations of the Blue Ribbon Commission on America's Nuclear Future.

Acknowledgments

The author thanks T. McCartin, B. Hill, K. Comp-ton, R. Einziger, C. Markley, C. Pineda, D. Dunn, A. Mohseni, and L. Kokajko of the NRC staff for thoughtful insights, discussion, and support. The views expressed herein are those of the author and do not constitute a final judgment or determination of the matters addressed or of the acceptability of any licensing action that may be under consideration by the U.S. Nuclear Regulatory Commission. Use of commercial products or trade names does not constitute endorsement by the U.S. Nuclear Regulatory Commission.

References

- Arnold, B.W., P.V. Brady, S.J. Bauer, S. Pye, C. Herrick, and J. Finger. 2011. Reference Design and Operations for Deep Borehole Disposal of High-Level Radioactive Waste. SAND2011-6749. Albuquerque, N.M.: Sandia National Laboratories.
- BRC (Blue Ribbon Commission on America's Nuclear Future). 2012. Report to the Secretary of Energy. Washington, D.C.: BRC. Available online at http://brc.gov/sites/default/files/documents/brc_finalreport_jan2012.pdf.
- EPRI (Electric Power Research Institute). 2011. Extended Storage Collaboration Program (ESCP)—Progress Report and Review of Gap Analyses. Technical Report 1022914. Palo Alto, Calif.: EPRI.
- GoldSim Technology Group LLC. 2010. GoldSim Probabilistic Simulation Environment User's Guide. Issaquah, Wash.: GoldSim Technology Group LLC.
- Hanson, B., H. Alsaed, C. Stockman, D. Enos, R. Meyer, and K. Sorenson. 2012. Gap Analysis to Support Extended

- Storage of Used Nuclear Fuel. PNNL-20509. Rev. 0. Richland, Wash.: Pacific Northwest National Laboratory.
- Kimball, C., and M. Billone. 2002. Dry Cask Storage Characterization Project. EPRI Report 1002882. Palo Alto, California: EPRI.
- Markley, C., O. Pensado, J. Gwo, J. Winterle, T. Ahn, R. Benke, T. Cao, H. Gonzalez, A. Gray, X. He, R. Janetzke, H. Jung, G. Oberson, P. Shukla, T. Sippel, S. Stothoff, and L. Tipton. 2011. SOAR: A Model for Scoping of Options and Analyzing Risk, Version 1.0. Washington, D.C.: U.S. Nuclear Regulatory Commission.
- NRC (U.S. Nuclear Regulatory Commission). 1977. Final Environmental Statement on the Transportation of Radioactive Material by Air and Other Modes, NUREG-0170. Washington, D.C.: NRC.
- NRC. 2001. Statements of Consideration for 10 CFR Part 63, Disposal of High-Level Radioactive Waste in a Proposed Geologic Repository at Yucca Mountain, Nevada. Federal Register 66, 55732-55786, November 2, 2001.
- NRC. 2003a. Safety of Spent Fuel Transportation, NUREG/BR-0292. Washington, D.C.: NRC.
- NRC. 2003b. Yucca Mountain Review Plan, NUREG-1804, rev.2. Washington, D.C.: NRC.
- NRC. 2007. A Pilot Probabilistic Risk Assessment of a Dry Cask Storage System at a Nuclear Power Plant, NUREG-1864. Washington, D.C.: NRC.
- NRC. 2009. Draft Technical Basis for Rulemaking Revising Security Requirements for Facilities Storing SNF and HLW; Notice of Availability and Solicitation of Public Comments. Federal Register 74, 66589, December 16, 2009.
- NRC. 2010a. Standard Review Plan for Spent Fuel Dry Storage Systems at a General License Facility—Final Report, NUREG-1536. Washington, D.C.: NRC.
- NRC. 2010b. Safety Evaluation Report Related to Disposal of High-level Radioactive Waste in a Geologic Repository at Yucca Mountain, Nevada, NUREG-1949, Volume 1: General Information. Washington, D.C.: NRC.
- NRC. 2010c. Consideration of Environmental Impacts of Temporary Storage of Spent Fuel After Cessation of Reactor Operation, and Waste Confidence Decision Update. Federal Register 75, 81032-81076, December 23, 2010.
- NRC. 2011a. Information Digest, NUREG-1350, Volume 23. Washington, D.C.: NRC.
- NRC. 2011b. Technical Evaluation Report on the Content of the U.S. Department of Energy's Yucca Mountain Repository License Application, Postclosure Volume: Repository Safety After Permanent Closure, NUREG-2107. Washington, D.C.: NRC.
- NRC. 2011c. Technical Evaluation Report on the Content of the U.S. Department of Energy's Yucca Mountain Repository License Application, Preclosure Volume: Repository Safety Before Permanent Closure, NUREG-2108. Washington, D.C.: NRC.
- NRC. 2011d. Technical Evaluation Report on the Content of the U.S. Department of Energy's Yucca Mountain Repository License Application, Administrative and Programmatic Volume, NUREG-2109. Washington, D.C.: NRC.
- NRC. 2011e. Background and Preliminary Assumptions for an Environmental Impact Statement—Long-Term Waste Confidence Update. Washington, D.C.: NRC.
- NRC. 2012a. Spent Fuel Transportation Risk Assessment: Draft Report for Comment, NUREG-2125. Washington, D.C.: NRC.
- NRC. 2012b. Identification and Prioritization of the Technical Information Needs Affecting Potential Regulation of Extended Storage and Transportation of Spent Nuclear Fuel: Draft Report for Comment. Washington, D.C.: NRC.
- NWTRB (Nuclear Waste Technical Review Board). 2010. Evaluation of the Technical Basis for Extended Dry Storage and Transportation of Used Nuclear Fuel. Arlington, Va.: NWTRB.
- Sindelar, R.L., A.J. Duncan, M.E. Dupont, P.-S. Lam, M.R. Louthan Jr., and T.E. Skidmore. 2011. Materials Aging Issues and Aging Management for Extended Storage and Transportation of Spent Nuclear Fuel, NUREG/CR-7116. Washington, D.C.: NRC.
- Sprung, J.L, D.J. Ammerman, N.L. Breivik, R.J. Dukart, F.L. Kanipe, J.A. Koski, G.S. Mills, K.S. Neuhauser, H.D. Radloff, R.F. Weiner, and H.R. Yoshimura. 2000. Re-Examination of Spent Fuel Risk Estimates. NUREG/CR-6672. Albuquerque, N.M.: Sandia National Laboratories.

The debate over managing high-level radioactive waste is really about extending proven technology and successful practices.

Industry's Safety Record and the Blue Ribbon Recommendations

The Way Ahead for the Management of Used Nuclear Fuel



Marvin S. Fertel is president and chief executive officer, Nuclear Energy Institute.

Marvin S. Fertel

Nuclear power plants are valuable producers of electricity that do not cause harm to the environment by discharging greenhouse gases or other regulated air pollutants into the atmosphere. In addition, nuclear energy is unique among major sources of electricity in that its primary by-products—used uranium fuel rods—remain safely contained on the sites where they have been used in nuclear reactors.

Nevertheless, the question of how the nuclear industry manages its highly radioactive used fuel rods is perceived to be extremely difficult, a problem yet to be solved. Despite the significant environmental benefits of nuclear electricity, public concerns about the management of high-level radioactive waste abound, based largely on a lack of information about the nature of these materials and the care with which they are managed.

In January 2012, President Obama's Blue Ribbon Commission on America's Nuclear Future (BRC) completed nearly two years of deliberations on this very question. The commission's recommendations provide a sound policy for moving forward (BRC, 2012), even though a policy is, in fact, already well established. The current policy includes proven technical solutions to the safe management of used fuel elements and the storage of used reactor fuel at plant sites. Strict licensing requirements and oversight of used fuel facilities by the U.S. Nuclear Regulatory Commission (NRC) provide another layer of protection for public safety and the environment.

Nevertheless, over the long term, consolidated storage, followed by ultimate disposal or advanced treatment of the fuel, would be preferable to the present policy.

The Nature of Used Nuclear Fuel

When considering policy approaches to managing used nuclear fuel, it is important to understand the physical nature of the material. To generate electricity, nuclear energy facilities use small, ceramic, uranium-oxide pellets as fuel. These pellets (about the size of a fingertip) are loaded into long, thin metal fuel rods, which are then grouped into bundles called fuel assemblies. A typical fuel assembly is about 12 feet long (Figure 1). Inside the reactor, uranium atoms in the pellets split in a process known as fission. The heat generated from this process is used to produce steam, which drives the turbines that produce electricity.

Over time, fissionable uranium in the fuel is consumed, and the radioactive by-products of the fission process accumulate inside the rods. Every 18 to 24 months, the reactor is shut down, and as much as one-third of the uranium fuel—the oldest fuel assemblies—is removed and replaced (Figure 2).

The used fuel assemblies are highly radioactive and will remain that way for several thousand years while the natural process of radioactive decay takes place. Nuclear fuel and other high-level radioactive wastes contain elements that present a potential radiation hazard to the public and environment if not handled properly. However, this hazard diminishes over time, often declining significantly in the first few hundred years and thereafter much more gradually.

Throughout the decay process, the used fuel remains solid, compact, and relatively small in volume. All of the used fuel rods from 50 years of electricity production by America's nuclear energy facilities could be stacked seven yards deep on one football field.

Safeguarding and Disposing of Used Nuclear Fuel

The primary question for policy makers is determining the best way for the federal government to safeguard and dispose of used nuclear fuel. There are two parts to this question: (1) steps that must be taken by industry now to protect the environment from radioactive materials in the fuel and (2) steps that must be taken by future generations to safeguard the materials, which will remain highly radioactive for thousands of years.

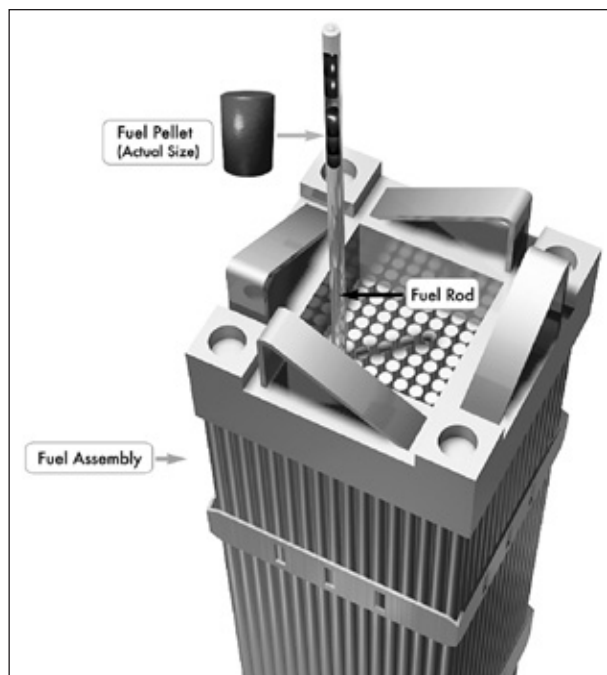

FIGURE 1 Uranium fuel at nuclear energy facilities is made of small ceramic pellets sealed into long, vertical metal alloy tubes. These tubes, the first of many layers of protection against radiation release, are grouped together in fuel assemblies.

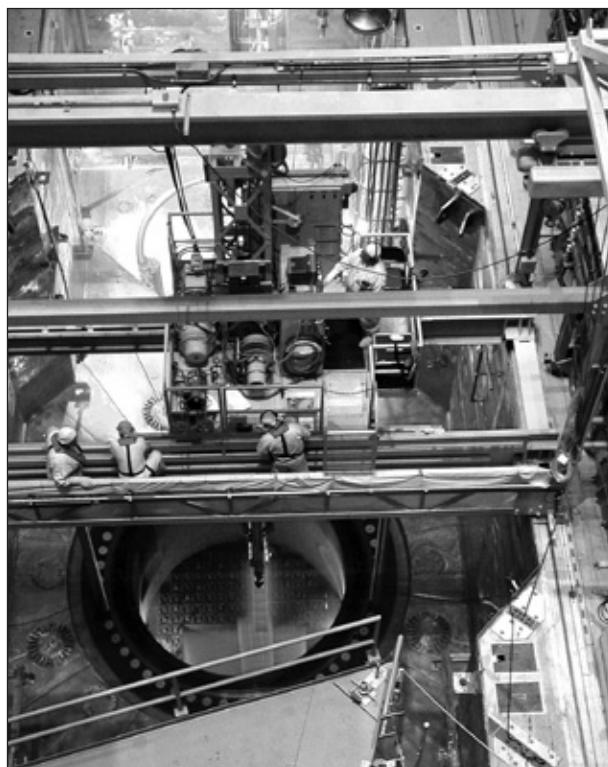

FIGURE 2 During refueling operations at nuclear energy facilities, older fuel assemblies are removed from the reactor and transferred underwater to a steel-lined concrete pool for safe storage.

Answers to both parts of the question are well known. Protection for the near term and foreseeable future is provided by storage pools and dry-container storage technology. Protection in the distant future will be provided by a geologic repository. Over the past several decades, much of the debate about used nuclear fuel has centered on the question of where a future repository will be located, rather than on the viability and safety of accepted storage and disposal methods.

Used Fuel Storage Systems

Storage Pools

There are three primary safety considerations for managing used nuclear fuel: (1) radiation protection and containment; (2) ensuring that fuel assemblies do not overheat; and (3) preventing an unintended nuclear chain reaction (a “criticality accident”).

When used fuel is first removed from a reactor, the used fuel assemblies are placed in steel-lined, concrete pools of water inside the power plant structures. The depth of the water is typically maintained at about 20 feet above the top of the fuel assemblies to provide radiation shielding for people working directly above the enclosed pool.

This volume of water, in combination with heat exchangers through which the water is circulated, also keeps the fuel cool, thus preventing damage to the fuel assemblies from overheating. Finally, the racks in which the fuel is placed at the bottom of the pools are specially engineered and configured to preclude the possibility of nuclear criticality.

These steel-lined concrete pools are extremely robust and are designed to protect the fuel under even the most severe conditions—a design philosophy that proved itself in extraordinary fashion during the 2011 earthquake and tsunami at Fukushima Daiichi, Japan. There were seven used fuel pools at the Daiichi site, containing approximately 10,000 used fuel assemblies (TEPCO, 2010). All of the pools maintained their integrity and protected the fuel assemblies throughout the event, even though some of them were located in reactor buildings that suffered catastrophic damage from hydrogen explosions associated with the reactor accidents (Figure 3).

The heat load associated with reactor fuel drops dramatically over time. After about five years in storage, used fuel has cooled enough for it to be removed from the pools. In the 1960s and 1970s, U.S. commercial reactors were designed with pools that had limited storage capacity under the assumption that the federal

government would remove the cooler assemblies for transportation either directly to a geologic repository for disposal or to a reprocessing or recycling facility where the radioactive by-products would be separated from reusable constituents prior to disposal.

However, in the 1980s, it became apparent that the U.S. Department of Energy’s (DOE’s) disposal program was well behind schedule and that this commitment would not be met before the pools reached their maximum storage capacity. This was true even though companies had expanded capacity by modifying storage racks in the pools.

Dry Storage Container Systems

The challenge of providing more capacity was met through the development of dry storage container technology, which has extended safe storage capacity at commercial reactor sites beyond the estimated operating period of the reactors. The first dry-container storage systems were placed in service at the Surry Nuclear Power Station in Virginia in 1986 (GTS, 2012). These above-ground systems—like the steel-lined pools—incorporate safety features to protect public health.

The foremost safety feature is the extremely rugged containers, which are made of steel, steel-reinforced concrete, or steel-enclosed concrete 18 or more inches thick—all materials that have been proven to be effective radiation shields. A typical container is about 20 feet tall and 11 feet in diameter and weighs more than 360,000 pounds when fully loaded. The makers of dry-container systems design and test them to



FIGURE 3 The robust construction of steel-lined concrete storage pools protected used uranium fuel rods even though hydrogen explosions ripped through the secondary containment buildings at three reactors at Fukushima Daiichi. Source: Tokyo Electric Power Company. Available online at <http://www.tepco.co.jp/en/news/library/movie-01e.html>.

ensure that they prevent the release of radioactivity even under extreme conditions—such as earthquakes, tornadoes, hurricanes, floods, and sabotage.

At the Fukushima Dai-ichi site when the earthquake and tsunami struck, there were nine loaded dry-cask systems, containing approximately 400 used fuel assemblies. None of the containers was damaged (TEPCO, 2010).

The containers and their enclosures, which involve

no moving parts, dissipate heat given off by the used fuel assemblies through natural circulation cooling. The containers are sealed and tested for leakage to a high standard to ensure that the used fuel assemblies are maintained in a benign inert-gas environment. The internal structures inside the containers are engineered with the same precision as the racks in the pools to ensure that no unintended nuclear criticality can occur (Figure 4).

Dry-storage containers can hold 24 to 87 used fuel assemblies—depending on the specific fuel type and the container design. To date, more than 1,500 dry casks have been loaded at 56 reactor sites in 30 states in the United States. Of the approximately 237,000 fuel rod assemblies that have been discharged from commercial reactors during the U.S. industry's 50-year history, approximately 65,000 have been removed from pools and loaded into dry-container systems. About 6,500 assemblies are loaded into 150 containers each year. By 2020, more than 2,600 dry storage systems will have been loaded at 75 locations in 33 states (GTS, 2012).

Industry's Safety Record

The storage systems described above have a stellar safety record, and no harmful radioactivity has been released to the environment. The industry's commitment to safety has been recognized by NRC, which oversees the operation of U.S. nuclear energy facilities. NRC's regulations originally called for dry-container storage systems to be licensed for 20 years, with an option for a 20-year renewal. Considering the extensive experience that has been gained since the first dry-container systems were put into service, in 2011



FIGURE 4 As used fuel storage pools reach capacity, energy companies are moving used uranium fuel rods to dry container storage for long-term storage at reactor sites.

NRC regulations were amended to provide for a 40-year license, with an option for a 40-year renewal (NRC, 2011).

In 2010, NRC stated that used fuel generated at any reactor “can be stored safely and without significant environmental impacts for at least 60 years beyond the licensed life for operation.” Given that 70 percent of U.S. reactors are already licensed for operation for up to 60 years, NRC has expressed confidence that it is safe to store used nuclear fuel at reactor sites for as long as 120 years—even though it is unlikely that fuel will remain at a site for that long (NRC, 2010).

When dry-container storage systems were originally loaded, it was not intended that they would remain at reactor sites indefinitely. In fact, 75 percent of the containers in service today were specifically designed to be transportable, as are new systems that will be loaded in the future. Storage systems that were not originally designed for transport would either have to be modified to make them transportable or unloaded at reactor sites where the used fuel could be transferred to a transportable system. In the latter case, the inner canisters, which hold the fuel rods, would be removed from the storage package and transferred to transportation packages designed to provide the same high level of protection during shipment.

Transport for Interim Storage or Reprocessing

Although the specific location to which containers will be shipped is not yet known, the types of facilities that will be needed at the other end are well understood. A strong, long-standing international scientific

consensus supports disposal of nuclear waste in a geologic repository as the ultimate, permanent solution. In addition, many experts believe there is a benefit to recycling used fuel to separate the radioactive by-products from reusable constituents prior to disposal; this is already being done in the United Kingdom and France.

Transporting used fuel away from reactor sites to consolidated storage locations for longer term storage prior to disposal or recycling is under consideration in the United States. In fact, a U.S. Senate subcommittee in April approved a fiscal year 2013 budget for DOE that included language supporting consolidation of used nuclear fuel at one or more storage sites.

About 86 percent of Americans believe that the nuclear energy industry should develop recycling technology to take advantage of the energy that remains in uranium fuel rods that have been removed from reactors.

According to a survey by Bisconti Research Inc./GfK Roper in February 2012, 64 percent of Americans believe that storing used nuclear fuel at reactor sites is safe, but three-quarters of U.S. adults surveyed agreed that it would be preferable to store used nuclear fuel at one or two consolidated storage facilities. The public was evenly split on whether the government's nuclear fuel management program should be managed by a corporate-style board of directors or a federal agency. However, a strong majority—86 percent—believe that America's nuclear energy industry should develop recycling technology to take advantage of the energy that remains in uranium fuel rods after they are removed from a reactor (NEI, 2012a).

An Integrated Plan for Managing Used Nuclear Fuel

The remainder of this article focuses on consolidated storage, potential recycling, and geologic disposal, which

are vital components of an integrated approach to managing used nuclear fuel. However, it should be noted that the dry-container storage systems in use today will also be an important component of the permanent solution.

Dual-Purpose and Transportation, Aging, and Disposal Containers

In 2008, while DOE was studying a potential geologic repository at Yucca Mountain in Nye County, Nevada, scientists developing the repository and industry designers of dry-container storage systems collaborated to develop a storage system design that could be both transported to and disposed of in the repository (DOE, 2008). This system—known as a transportation, aging, and disposal (TAD) container—was under licensing review by NRC when the Yucca Mountain project was terminated in 2010 for policy, not technical reasons.

Although work on TAD containers was never completed, the program demonstrated the utility of a system by which radioactive by-products in used fuel could be packaged, in reactor pools, in containers that would never have to be reopened. At the same time, the industry sought to qualify dual-purpose systems that were already loaded for disposal in Yucca Mountain. Based on substantial technical analysis (EPRI, 2008), the nuclear energy industry filed contentions in the Yucca Mountain licensing process seeking to amend the repository license to allow for the disposal of fuel loaded in dual-purpose systems.

Although the Yucca Mountain project was terminated by the Obama administration before the potential of disposable dry-storage containers could be realized, it is possible that the next effort to design a repository could capitalize on this potential. If direct disposal of dry-container storage systems were pursued, it would mean that one element of the infrastructure for permanent isolation of radioactive by-products of nuclear energy is already in use today.

Consolidated Storage

Even though it is feasible for industry to safely store used nuclear fuel at reactor sites for more than 100 years, this may not be the most practical approach. When the storage of used fuel is co-located with an operating reactor, the additional costs for storage are not significant. However, when a reactor is shut down and the used fuel must be maintained on the site in dry-cask systems as a stand-alone facility—as is the

case at some U.S. locations (GTS, 2012)—the costs are high. In addition, the land upon which this facility sits remains unavailable for future use by nearby communities. Even where used fuel is co-located with operating reactors, efficiencies—beginning with the development of a common monitoring, inspection, and security infrastructure—could be gained by moving the fuel to consolidated locations.

For these reasons, BRC has recommended “prompt efforts to develop one or more consolidated storage facilities” (BRC, 2012). In a letter dated April 23, 2012, to Senators Dianne Feinstein and Lamar Alexander, BRC co-chairs Lee Hamilton and Brent Scowcroft wrote that proposed legislation in the U.S. Senate to develop consolidated storage “incorporates several key recommendations of the Blue Ribbon Commission on America’s Nuclear Future and is a positive step toward the goal of creating an integrated nuclear waste management system in the United States.” The nuclear energy industry supports the proposed legislation and has also recommended to Congress and DOE that consolidated storage be implemented in a timely manner.

There are international precedents for the success of consolidated storage. Sweden and Switzerland operate independent facilities for dry-container storage (NWTRB, 2009), and Spain recently selected a site for a similar facility (Frayer, 2012; Reuters, 2011; WNN, 2012).

In 2006, NRC granted a license to Private Fuel Storage LLC for a commercial consolidated storage facility in Utah that would be capable of storing approximately two-thirds of all U.S. commercial used fuel (NRC, 2006). In the face of state opposition, the Utah facility has yet to be developed, but other states and communities have expressed interest in hosting such a facility, in part because of the economic development that is expected to accrue to host communities.

Geologic Disposal for Permanent Isolation

A long-standing consensus among scientific organizations worldwide supports

the disposal of used fuel and high-level radioactive waste underground in a specially designed repository. In such a facility, a combination of engineered and natural features would isolate the radioactive by-products deep beneath the earth’s surface for the thousands of years it will take for the level of radioactivity to decay to the point at which it no longer presents a health or environmental hazard. More than a dozen nations are pursuing this approach. Finland (Figure 5), Sweden, and France are expected to complete construction of geologic repositories in 2020, 2023, and 2025, respectively (NWTRB, 2011).

In the United States, from 1982 to 2010, one of the most exhaustive scientific programs ever undertaken was focused on a potential geologic repository site at Yucca Mountain in Nevada. This effort resulted in a comprehensive safety analysis that showed the proposed repository would protect public health and safety for one million years, with radiation exposures from the repository expected to be equal to a fraction of natural background radiation—well below regulatory limits (DOE, 2008). This safety analysis was under review by NRC when DOE terminated the Yucca Mountain project for policy reasons.

Nevertheless, the scientific work that was completed on the Yucca Mountain project provides a powerful indicator of the safety benefits of geologic disposal. Similar safety analyses are under review by regulatory authorities in Sweden and Finland (and will be initiated in the near future in France). Each of these projects is moving forward with strong support from local communities.



FIGURE 5 The Onkalo repository is a huge system of underground tunnels in Finland that is being hewn out of solid rock. The facility is being designed to protect the environment for 100,000 years. Source: Posiva Oy. Available online at http://www.posiva.fi/en/databank/image_gallery?gfid_1042=94&gpid_1042=1851#gallery_1042.

In fact, the concept of geologic disposal is already being successfully demonstrated in Carlsbad, New Mexico, at the Waste Isolation Pilot Plant (WIPP), an operating repository for long-lived radioactive waste. In 1999, WIPP began receiving shipments of radioactive by-products from U.S. Department of Defense programs containing some of the same long-lived radioactive constituents found in used fuel. So far, the facility has received more than 9,000 shipments of radioactive waste for disposal in salt formations more than 2,000 feet below the earth's surface (DOE, 2007, 2010, 2011).

Billions of dollars have been spent worldwide studying and refining approaches to geologic repositories. In 2001, the U.S. National Academy of Sciences concluded: "After four decades of study, geologic disposal remains the only scientifically and technically credible long-term solution available" (National Research Council, 2001). Similarly, in 2003, the International Atomic Energy Agency concluded, "In a generic way, it can be stated with confidence that deep geological disposal is technically feasible and does not present any particularly novel rock engineering issues. The existence of numerous potentially suitable repository sites in a variety of host rocks is also well established" (IAEA, 2003).

Since 1999, the Waste Isolation Pilot Plant (WIPP) in Carlsbad, New Mexico, has received more than 9,000 shipments of radioactive waste for disposal in salt formations more than 2,000 feet below the surface.

Clearly, the relevant question about geologic disposal facilities is not whether, but when and where they will be developed. In the United States, until the time and place have been agreed upon, used fuel storage technology will continue to protect public health and safety.

Recycling to Enhance Disposal and Energy Production

There is broad agreement that disposal in a geologic repository represents the ultimate solution to the permanent isolation of long-lived radioactive by-products of nuclear fission. However, there are two schools of thought about the form in which these by-products should be disposed.

The approach pursued in most countries, including the United States thus far, is the direct disposal of used fuel. This would permanently isolate radioactive by-products but would not take advantage of the vast energy content remaining in the fuel. For this reason, several countries, including the United Kingdom and France, recycle or reprocess used fuel to separate the radioactive by-products for disposal and reuse the fissionable uranium and plutonium to make new fuel elements.

Although the United States does not recycle reactor fuel—and there are significant questions about whether it is economical to do so—DOE is sponsoring ongoing research to improve recycling methods that could make this option more attractive. Depending on future uranium supplies and advances in recycling technologies, the United States may turn to this course of action. Doing so would provide additional supplies of energy and make possible the development of tailored waste forms that would enable more efficient use of geologic repository capacity.

The Federal Government's Obligation

Despite industry's outstanding safety and security record and considerable progress around the world toward implementing geologic disposal, the public and policy makers in the United States continue to raise concerns about the management of used nuclear fuel. This is due, in part, to the federal government's failure to develop sustainable spent fuel management solutions.

In 1982, the Nuclear Waste Policy Act codified the federal government's obligation to remove used nuclear fuel from reactor sites and dispose of its radioactive by-products in a geologic repository. As required by this law, the government entered into contracts with the owners of America's commercial nuclear energy facilities to begin removing used fuel from reactor sites by 1998.

To date, the government remains unable to meet this legal requirement, and billions of dollars paid by the industry into a Nuclear Waste Trust Fund have been diverted to help balance the federal budget. Inaction also has undermined confidence in the overall

management of used nuclear fuel. Even though this lack of confidence does not reflect shortcomings in the industry's ongoing safe management of nuclear materials or NRC's oversight of the program, it is vitally important that action be taken to reform the federal program so a permanent solution can be developed.

The President's Blue Ribbon Commission has recommended reform of the DOE program, including the creation of an independent program management entity with unrestricted access to the Nuclear Waste Fund. The commission also recommended a new consent-based process for selecting both a consolidated storage site and a repository site. If implemented, these measures would help resolve the impasse (BRC, 2012). The U.S. industry strongly supports the BRC recommendations and looks forward to prompt action by the president and Congress to enact the necessary reforms (NEI, 2012b).

Conclusion

The storage of used nuclear fuel is among the best understood and most effectively managed responses to the environmental challenges associated with electricity production. For several decades, the nuclear energy industry has successfully used dry-container storage technology to ensure that public health and safety are protected—today and for the foreseeable future. The debate over high-level radioactive waste is, in reality, about how to extend proven technology and successful practices so future generations will enjoy the same level of protection, as well as the benefits of nuclear energy.

There are promising opportunities for the development of a repository, perhaps complemented by advanced recycling technologies. The recent recommendations of the President's Blue Ribbon Commission provide an excellent policy platform for developing short- and long-term approaches to satisfy the federal government's commitment to the nuclear energy industry and consumers of electricity produced by America's 104 reactors.

References

- BRC (Blue Ribbon Commission on America's Nuclear Future). 2012. Report to the Secretary of Energy. Available online at http://brc.gov/sites/default/files/documents/brc_finalreport_jan2012.pdf.
- DOE (Department of Energy). 2007. WIPP Chronology. Available online at www.wipp.energy.gov. February 5, 2007.
- DOE. 2008. Transportation, Aging, and Disposal Canister System Performance Specification. Revision 1 / ICN 1. WMO-TADCS-000001. DOE/RW-0585. Washington, D.C.: DOE.
- DOE. 2010. WIPP Receives 9,000th Shipment. October 7. Available online at <http://www.id.doe.gov/news/PressReleases/PR101008.htm>.
- DOE. 2011. WIPP Receives First Remote-Handled Waste Shipment from Sandia Labs. December 21. Available online at http://www.wipp.energy.gov/pr/2011/First_RH_Shipment_SNL.pdf.
- EPRI (Electric Power Research Institute). 2008. Occupational Risk Consequences of the Department of Energy's Approach to Repository Design, Performance Assessment and Operation in the Yucca Mountain License Application. EPRI Report # 1018058. August. Palo Alto, Calif.: EPRI. Available online at <http://www.brc.gov/sites/default/files/documents/1018058.pdf>.
- Frayner, L. 2012. Spanish Town Cheers New Nuclear Waste Plant. Available online at <http://www.npr.org/2012/01/16/145309330/spanish-town-cheers-new-nuclear-waste-plant>.
- GTS (Gutherman Technical Services). 2012. 2011 Used Fuel Data. January 14. Proprietary report to the Nuclear Energy Institute.
- IAEA (International Atomic Energy Agency). 2003. Scientific and Technical Basis for the Geological Disposal of Radioactive Wastes. IAEA Technical Reports Series No. 413. New York: IAEA.
- National Research Council. 2001. Disposition of High-Level Waste and Spent Nuclear Fuel: The Continuing Societal and Technical Challenges. Washington, D.C.: National Academy Press. Available online at http://www.nap.edu/catalog.php?record_id=10119.
- NEI (Nuclear Energy Institute). 2012a. U.S. Public Opinion About Nuclear Energy Stabilizes, February 2012. Available online at <http://www.nei.org/resourcesandstats/documentlibrary/safetyandsecurity/reports/us-public-opinion-about-nuclear-energy-stabilizes-february-2012>.
- NEI. 2012b. NEI Commends House Subcommittee for Approach to Nuclear Energy in Budget Bill. Available online at <http://www.nei.org/newsandevents/newsreleases/nei-commends-house-subcommittee-for-approach-to-nuclear-energy-in-budget-bill/>.
- NRC (Nuclear Regulatory Commission). 2006. NRC Issues License to Private Fuel Storage for Spent Nuclear Fuel Storage Facility in Utah. USNRC News No. 06-028, February 22. Washington, D.C.: NRC.
- NRC. 2010. Consideration of Environmental Impacts of Temporary Storage of Spent Fuel after Cessation of Reactor Operation, USNRC Final Rule. 75 Federal Register 81032. December 23, 2010.

- NRC. 2011. Duration of license; renewal. 76 Federal Register 8890, 10 CFR 72.42. USNRC Final Rule, February 16, 2011.
- NWTRB (Nuclear Waste Technical Review Board). 2009. Survey of National Programs for Managing High-Level Radioactive Waste and Spent Nuclear Fuel: A Report to Congress and the Secretary of Energy. Washington, D.C.: USNWTRB.
- NWTRB. 2011, Experience Gained From Programs to Manage High-Level Radioactive Waste and Spent Nuclear Fuel in the United States and Other Countries: A Report to Congress and the Secretary of Energy. Washington, D.C.: USNWTRB.
- Reuters. 2011. Spain names site for delayed nuclear waste dump. Available online at <http://www.reuters.com/article/2011/12/30/spain-nuclear-idUSL5E7KN2OW20111230>.
- TEPCO (Tokyo Electric Power Company). 2010. Integrity Inspection of Dry Storage Casks and Spent Fuels at Fukushima Daiichi Nuclear Power Station. Presentation by Yumiko Kumano at ISSF 2010: Session 6, November 16, 2010. Available online at http://criepi.denken.or.jp/result/event/seminar/2010/issf/pdf/6-1_powerpoint.pdf.
- WNN (World Nuclear News). 2012. Spain selects site for waste storage. Available online at http://www.world-nuclear-news.org/WR_Spain_selects_site_for_waste_storage_0301121.html.

Lessons learned from prior experience and social science research can influence public attitudes toward nuclear management facilities.

Enhancing the Acceptability and Credibility of a Repository for Spent Nuclear Fuel

Hank C. Jenkins-Smith, Carol L. Silva, Kerry G. Herron, Sarah R. Trousset, and Rob P. Recharad



Hank C. Jenkins-Smith



Carol L. Silva



Kerry G. Herron



Sarah R. Trousset



Rob P. Recharad

Public attitudes about the management of spent nuclear fuel (SNF) and high-level waste (HLW) are closely related to general attitudes about nuclear energy. Thus, understanding how perceptions and preferences about nuclear energy have evolved in recent years provides a necessary context for making sense of public beliefs, concerns, and preferences for managing SNF. This article describes some of the lessons learned about public acceptance of nuclear storage and disposal facilities in the United States over the past several decades.

Hank C. Jenkins-Smith is professor of political science, University of Oklahoma. Carol L. Silva is associate professor of political science and director of the Center for Risk and Crisis Management, University of Oklahoma. Kerry G. Herron is a research scientist, and Sarah R. Trousset is a doctoral student and research assistant at the Center for Risk and Crisis Management, University of Oklahoma. Rob P. Recharad is a risk analyst at Sandia National Laboratories, Albuquerque, New Mexico.

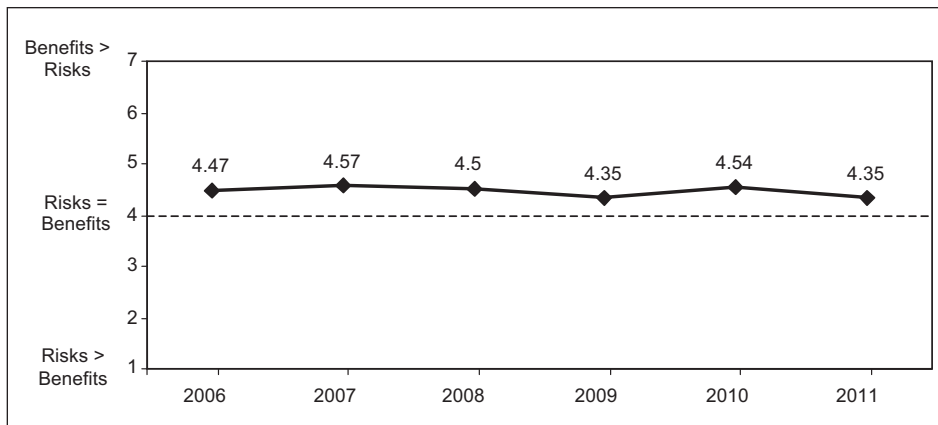

FIGURE 1 Americans' assessments of the balance of risks and benefits of nuclear energy. Source: Herron et al., 2012.

Public Perceptions of Nuclear Energy

The level of public acceptance for nuclear facilities is linked to people's intuitive balancing of the perceived risks and benefits associated with those facilities (e.g., Jenkins-Smith and Kunreuther, 2001; Slovic et al., 1991b). In the case of civilian nuclear energy, the U.S. public perceives the balance to be generally positive.

The National Security and Nuclear Policies (NSNP)¹ project has been using surveys to track the overall balance of perceived risks and benefits of nuclear energy since 2006. Participants were first asked to consider a number of specific risks (e.g., releases of radiation due to accidents at plants or during the transport of nuclear fuel; terrorist attacks; diversion of materials from SNF for nuclear weapons) and benefits (e.g., reliable production of base energy; reductions in reliance on energy imports; reductions in greenhouse gas emissions) of nuclear energy. Representative samples of respondents were then asked to assess the overall balance of risks and benefits on a scale of one (risks greatly exceed benefits) to seven (benefits greatly exceed risks).

Mean values for 2006 through 2011 are shown in Figure 1 (sampling error for each year is <3 percent). As the data show, Americans consistently view nuclear energy as having greater benefits than risks.

The perceived risks of nuclear energy—like the risks associated with all energy sources—are necessarily

relative. In the past few years, when the risks posed by nuclear energy were put into a comparative context, they were seen as equivalent to, or slightly lower than the risks from fossil fuels (Herron and Jenkins-Smith, 2010, p. 84). On average, members of the public would prefer a substantial increase in reliance on nuclear energy in the overall energy supply over the next 20 years. When

respondents were informed about the current mix of U.S. energy supplies,² most of them said they would like to see the fraction of U.S. energy from nuclear generation increase, from 8 percent to 22 percent (a 275 percent increase), over the next two decades (Figure 2).

When asked whether they favored construction of new reactors at existing plants or at *new* sites (on a scale of one [strongly oppose] to seven [strongly support]), the average level of support was higher for construction at existing plants. In fact, the level of support has declined only slightly since 2006, *even after the events at Fukushima*. From 2006 to 2011, the average level of support decreased approximately 7 percent for adding reactors at the sites of existing nuclear power plants and by 4 percent for building reactors at new sites (Figure 3).

Public acceptance of policy options for managing used nuclear fuel and HLW must be measured in this context. Public acceptance of management options for SNF will be conditioned by the current environment of increasing support for reliance on nuclear energy, as well as sustained support for constructing new nuclear energy reactors.³

Public Perceptions of Spent Nuclear Fuel

In contrast to nuclear energy, in the United States and elsewhere, both SNF and HLW were considered

¹ The NSNP project surveys are sponsored by Sandia National Laboratories and the University of Oklahoma. The surveys are collected annually, in May and June. Internet surveys are collected once a year. Companion telephone surveys are collected periodically to take into account the effect of the "mode of collection" on the responses. For an overview, see Herron and Jenkins-Smith (2010); Jenkins-Smith and Herron (2009); and Jenkins-Smith et al. (2011).

² The proportions shown are averages from the Sandia National Security Survey for 6 years (2006 to 2011). The yearly averages have fluctuated very little over time.

³ The results of the NSNP project are consistent with the findings of other, less comprehensive, measures of attitudes toward nuclear energy (Jones, 2009). The NSNP data also show that support for nuclear energy is greater among males, people with higher incomes, and people with higher levels of education; this is also consistent with other findings.

“wastes” with dreaded risks and few offsetting benefits.⁴ In this climate, attempts to provide inducements for communities or states to accept SNF can backfire if they are perceived as confirmation that the risks are dire (Jenkins-Smith and Kunreuther, 2005; Kunreuther and Easterling, 1998).

In addition to the perceived physical risks from such “wastes,” other research has suggested that “perception-based impacts” may stigmatize and impose social and economic losses on host communities and states (Easterling and Kunreuther, 1993; Gawande and Jenkins-Smith, 2001). Sustained public and state-level opposition to the siting of the Yucca Mountain repository (Slovic et al., 1991c), coupled with the U.S. Department of Energy’s (DOE’s) decision to withdraw the license application and terminate the project in 2010, illustrates the difficulty of finding willing host communities for facilities designed to manage and dispose of SNF and HLW.

However, recent successes in finding willing host communities for SNF disposal in Sweden and Finland have stimulated new thinking about the possibilities of siting SNF management facilities (Elam and Sundqvist, 2009). In the United States, the successful licensing and ongoing operations of the Waste Isolation Pilot Plant (WIPP) near Carlsbad, New Mexico, have also generated some optimism that the presence of disposal facilities for nuclear materials might be acceptable to some communities. Studies of public attitudes toward

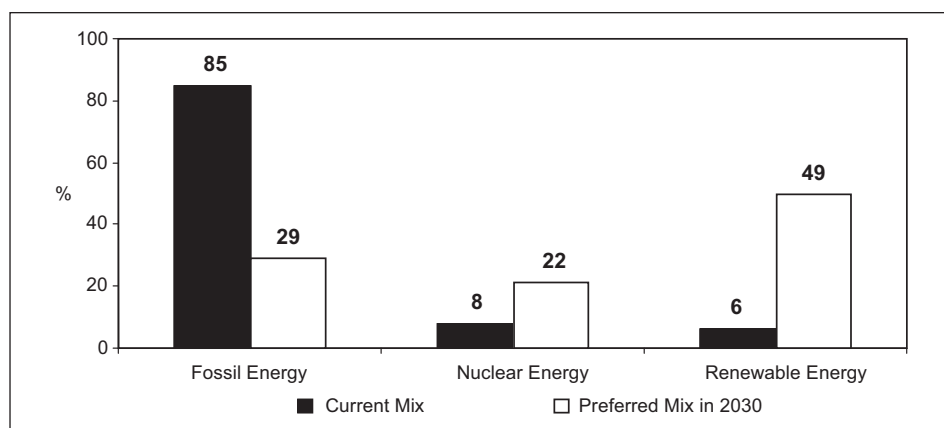

FIGURE 2. Preferred mix of total energy sources for 2030. Source: Herron et al., 2012.

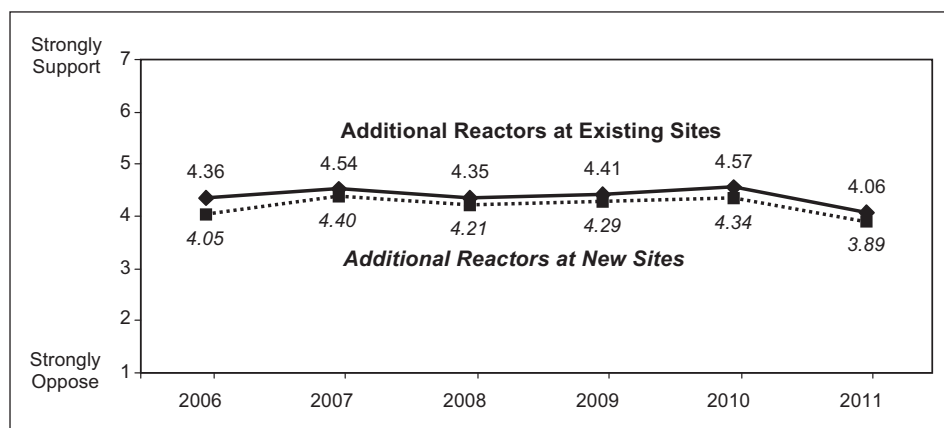

FIGURE 3 Preferences for the construction of new reactors at current or new sites. Source: Herron et al., 2012.

SNF disposal (based on the NSNP program initiated in 1993), and experience with WIPP and the proposed Yucca Mountain repository, provide important lessons for future efforts to site nuclear materials facilities.⁵

Public Understanding of Spent Nuclear Fuel and Related Policies

Members of the public are capable of developing reasoned policy preferences about complex issues (Herron and Jenkins-Smith, 2006; Lupia and McCubbins, 1998), but public understanding of such issues tends to evolve from inchoate opinions toward stable judgment only as policy debates mature (Yankelovich, 1991). Evidence collected by the NSNP project indicates that public opinion on the SNF issue has not fully matured.

For example, consider the widespread misunderstanding of current SNF practices in the United States.

⁴ See Slovic et al. (1991a) on nuclear waste. A powerful example of issue-framing in public debates has been widespread reference to spent (or used) nuclear fuel as “nuclear waste” and of repositories as “nuclear waste dumps.” Designation of a substance as a waste implies that it has no further use or purpose other than disposal, and hence poses only risks.

⁵ For the most recent published summary of the Sandia National Security Survey Project, see Herron et al. (2012).

Until very recently, a plurality (one-third) of survey respondents believed that SNF was already being shipped to Nevada for permanent disposal. Despite ongoing news reports about the long-running debate over the Yucca Mountain repository, many people neither sought nor monitored information on SNF management practices.⁶

Nevertheless, there has been a modest trend toward a more widespread public understanding that SNF is usually stored at or near civilian nuclear reactors. From 2006 to 2011, the fraction of respondents who knew that SNF is stored in special containers at nuclear power plants throughout the United States increased from 1 in 5 to 4 in 10 (40 percent in the 2011 iteration of the survey, substantially more than the 23 percent who still believe SNF is sent for deep geologic disposal in Nevada).

However, when asked if SNF was stored at any site in their own states, only 13 percent could answer correctly. Thus, although public understanding appears to be improving modestly over time, there is some distance to go before opinion evolves to support a clear and stable aggregate public judgment about SNF policy.

*When given basic
background information,
many people express
differentiated, stable opinions
about complex issues.*

Given the current level of public understanding, it is all but impossible to measure preferences as a basis for analyzing the prospects for acceptance of SNF management facilities unless a basic level of background information is provided to survey respondents. However, once such information is provided, members of the public are able to express differentiated, stable opinions, even about complex issues of this kind, grounded in their broader belief systems (Herron and Jenkins-Smith,

⁶ For the pattern of news coverage since 2004, as well as the volume of internet search activity, for Yucca Mountain, use "Yucca Mountain" as the search term at Google Trends™, accessible at <http://www.google.com/trends>.

2006). The NSNP project has used this approach to track public assessments of current policies and to evaluate variations in public acceptance of SNF management options for alternative design characteristics for policies and facilities.

Public Evaluation of Current Management Practices

Evaluation of current SNF storage practices requires that survey participants be apprised of the primary points of view of both proponents and opponents of continued on-site storage, in a way that does not privilege one argument over the other.⁷ With that in mind, the following background information on current SNF policy was provided to NSNP participants:

Currently, US spent nuclear fuel is being temporarily stored at over 100 sites in 39 states. Most of it is stored at nuclear power plants where it is placed in secure cooling pools. In some cases, the spent fuel is transferred to specialized concrete casks stored above ground near the nuclear power plant. At each site, the cooling pools and storage casks are protected at all times by security forces. Some people think this is an acceptable solution for the foreseeable future, while others think such practices are risky and other options need to be adopted.

The following arguments were then presented in randomized order:

Opponents argue that some nuclear power plants where spent nuclear fuel is stored are near rivers, oceans, and large population centers. On rare occasions spent fuel has leaked radiation into the cooling pools. Moreover the cooling pools and containers are located at ground level, and therefore might be vulnerable to terrorists. They note that these storage practices do not provide a permanent solution for managing spent nuclear fuel.

Supporters argue that transporting spent nuclear fuel by train or truck to consolidated storage facilities is risky, that storing spent nuclear fuel at nuclear power plants is less expensive than consolidated storage, and that it buys time for finding future solutions. Moreover, storage at nuclear power plants has not caused any accidents that have exposed the public to radiation.

Survey respondents were then asked how they felt about the current practice of storing SNF at or near

⁷ The objective in survey design of this kind is to provide, in brief and accessible form, the range of arguments that the public is likely to encounter in public debate on the issue.

nuclear power plants, based on a scale of one (strongly oppose) to seven (strongly support). Mean responses from 2006 to 2011 were consistently below mid-scale (3.4–3.7). In 2011, 46 percent of respondents opposed indefinite on-site storage, 30 percent were undecided, and 24 percent favored continuing the current practice. These responses indicate that, although the public is decidedly uneasy about indefinite on-site storage, there remains significant latitude for continued policy development.⁸

Policy Design Options

An analysis of results from the most recent 2011 NSNP survey, and of the policy debate concerning SNF in Europe, suggests that two related considerations underlie public acceptance of SNF management strategies: (1) whether SNF is designated a waste or a resource; and (2) whether society should be able to make changes to improve the safety of the materials in the storage/disposal facility. These considerations are directly related to “retrievability” in the design of SNF repositories.

Retrievability

Retrievability (i.e., the ability to remove SNF from a storage facility) has become a central issue in public debates about the acceptance of SNF disposal siting in Europe (see e.g., OECD-NEA, 2001, 2009). In debates in Finland about facility siting, integrating retrievability into the design of disposal facilities for SNF was one of the few concrete results of very extensive public engagement on the issue (Hokkanen and Kojo, 2003). Subsequently, Finland was the first state to successfully site a permanent repository near a host community, Eurajoki.

In the United States, the issue of retrievability of SNF has received little public consideration, although discussions by focus groups in the late 1990s suggested that future generations should have the option of removing SNF from disposal facilities if new knowledge or changed circumstances warranted such action.⁹

The NSNP project queried the implications of retrievability in repository design for public acceptance

of SNF facility siting by presenting balanced arguments for and against.¹⁰ Respondents were then asked to indicate how they felt, on a scale of one (strongly oppose) to seven (strongly support), about the following options, presented in random order:

Construct sites so that stored materials are monitored and could be retrieved for reprocessing or further treatment in the future.

Construct sites so that stored materials are permanently sealed away and cannot readily be retrieved in the future.

In Europe, retrievability has become a central issue in public debates about SNF disposal siting.

Overall, 60 percent of respondents supported the retrievable design (with a mean response of 4.72), and 38 percent expressed support for the non-retrievable design (mean response 4.02). When asked to rank the two options, 69 percent preferred the retrievable option. In sum, although neither option generated strong opposition, the inclusion of retrievability in the repository design was preferred by a two-to-one margin.

Waste or Resource

Available evidence suggests that broad public support for retrievability is based on two distinct considerations. The first is whether SNF is understood by the public to be a waste or a potential resource that can be reprocessed in the future. Since we began measuring attitudes about reprocessing in 2008, responses have been consistent; a substantial majority has expressed support

⁸ Another indicator of latitude for continued policy development is that in 2011 only 16 percent of the responses fell on the scale endpoints (“strongly oppose” or “strongly support”).

⁹ These focus groups were conducted in Nevada, New Mexico, and Illinois as part of a research project undertaken by the University of New Mexico’s Institute for Public Policy in 1998. The results were summarized in Bassett et al. (1998).

¹⁰ The wording was as follows: “Now we want you to consider the issue of whether stored radioactive materials should be managed in a way that allows authorized personnel to gain access to them and retrieve the materials in the future, or that seeks to permanently block access to them. One option is to build facilities where the stored materials are continuously monitored and can be retrieved for reprocessing, or possibly to make them less dangerous using future technological developments. This option requires increased security and may mean the facility is more vulnerable to attack or theft. Another option is to attempt to seal off storage sites in such a way that people cannot readily gain access to the materials in the future. This option is more secure, but does not allow reprocessing or treatment by future technological advancements.”

for the reprocessing option (ranging from 59 to 67 percent in favor). Fewer than 20 percent of respondents have expressed opposition in any one year (e.g., fewer than 16 percent of all respondents in 2011).

Note that these results were obtained despite reminders that uranium and plutonium, when separated by reprocessing, could be used to make nuclear weapons. The public thus broadly perceives SNF to be a potential resource.

Americans have expressed optimism that future developments in science and engineering will lead to options that current technologies do not support.

Retaining Future Options

The second basis for support for a retrievable SNF repository design is potential future improvements in safety. In the European debate over SNF disposal, a distinction is made between retrievability (physical retrieval of SNF from a repository) and reversibility (the option of changing the disposal policy if better options become available) (OECD-NEA, 2001, p. 11).

In the American context, findings based on focus groups suggest substantial optimism that future developments in science and engineering will lead to options that current technologies do not now support. Therefore, they reason, permanent closure of a repository would preclude taking advantage of those options (Bassett et al., 1998).¹¹

More conclusive evidence of a public preference for retaining the option to take advantage of future learning is available from the NSNP project, which in 2010 and 2011, asked whether support for siting a repository would change if the repository was combined or co-located with a research laboratory focused on finding ways to improve the safety and efficiency of managing SNF. When this option was included, support for the

facility increased substantially, even among those who were initially opposed to siting the facility (see more detailed discussion below).

Given the public sensibilities about retrievability described above, how do specific repository design factors shape public support for SNF management facilities? Now that DOE has withdrawn its license application for the repository at Yucca Mountain, it is possible to consider a wide range of options. Primary policy design features that may have significant implications for public acceptance include: (1) the number of sites considered; (2) the type of storage and storage depth for SNF at these sites; and (3) whether the repository function will be combined with other activities at the facilities. In 2010 and 2011, NSNP investigated the implications of each of these features for public acceptance.

The Number of Storage Sites

Three options appear to be plausible: (1) continued, dispersed, on-site storage facilities, chiefly on sites of operating nuclear reactors; (2) a number of regional facilities, perhaps designed to optimize SNF transport; and (3) one or two centralized facilities. The 2010 and 2011 NSNP questionnaires measured relative public preferences for a characterization of each option.

Respondents were first asked to consider the preferred number of facilities,¹² then to rate their preferences for each option on a scale of one (strongly oppose) to seven (support), and then to rank the options from most to least preferred.

After spent nuclear fuel is removed from the cooling pools, continue the current practice of temporarily storing it above ground at designated nuclear power plants. This option does not require additional transportation of radioactive materials by train or truck, and it presents few additional political or legal obstacles.

Construct six to eight regional storage sites that can be more easily secured and can provide longer-term storage. This option requires transporting spent nuclear fuel by

¹¹ One example is deep borehole disposal, which has become more promising over the last decade with advances in deep drilling.

¹² The wording was as follows: "While nuclear power plants will continue to store some spent fuel in their cooling pools, much of the radioactive materials currently at temporary storage sites in 39 states might be consolidated at a smaller number of regional or central facilities. Once it is consolidated, the spent nuclear fuel can more easily be secured and protected from attack. The fewer the number of regional or central storage facilities, the less complex are the political and legal obstacles for finding communities willing and able to host the facilities. At the same time, a larger number of regional storage facilities would reduce the distances radioactive materials must be transported by train or truck, and would also reduce the number of communities through which the transport routes would pass."

train or truck over moderate distances and is likely to generate political and legal opposition.

Construct two large centralized storage sites (one in the west and one in the east) that can be most secure and provide permanent storage. This option requires transporting spent nuclear fuel by train or truck over longer distances and is likely to generate political and legal opposition.

The average levels of support in 2011 on the scale of one to seven for (1) continued on-site storage, (2) six to eight regional sites, or (3) two centralized repositories were 4.02, 4.14, and 3.85, respectively. Mean preferences for continued on-site storage and multiple regional repositories were statistically indistinguishable, and both were preferred to the option of two centralized repositories.

Several conclusions can be drawn from these results. Strong preferences for the number of repositories have yet to develop, suggesting that there is considerable latitude for working toward an acceptable option. For each option considered, the modal response was the scale mid-point (indicating uncertainty or lack of preference). Strongly held positions (either in support or opposition) were near or below 20 percent for all three options.

At the same time, support for a larger number of sites—whether regional or continued at reactors—was greater than support for two centralized sites. This suggests that the public would not rule out, at least in theory, multiple storage/disposal facilities.

Prospective difficulties with obtaining acceptance from people living near those sites, the so-called not-in-my-backyard (NIMBY) reaction, are discussed below.

The Depth of a Storage Site

Another critical design factor is the depth at which SNF is stored; this can plausibly range from ground level to miles below the surface. NSNP respondents in 2011 were asked to consider their preferences for two possible designs: surface storage and storage/disposal in a deep geologic mine repository. The two options were posed as follows, in random order:

One option is to store spent nuclear fuel at or near the surface in hardened structures of concrete and steel. This allows monitoring and retrieval, but it is considered to provide a safe means to manage the material for only about a hundred years.

One option is to build mine-like storage facilities that are thousands of feet underground. These can be

constructed to allow materials to be retrieved, or they can be designed to permanently block access in the future. They are suitable for storage over thousands of years.

Respondents indicated their support for each option on a scale of one (strongly oppose) to seven (strongly support). In 2011, support for a mine-like deep geologic storage scored highest (4.80); support for the ground-level option was 3.84. Among the NSNP respondents, the mine-like geologic option is the clear preference for depth.

However, because the characterizations of the options emphasized the implications of each choice for retrievability and suitability for long-duration of storage, respondents' preference for the mine-like repository may reflect the characterization of that option as affording both retrievability and the ability to seal the materials for "thousands of years." This is consistent with the more general preference for retrievability discussed above.

Combining a Storage/Disposal Site with Other Facilities

As we have seen, design features of a repository may have important implications for the acceptance of a facility by prospective host communities. The Yucca Mountain repository was designed exclusively as a disposal facility to be permanently sealed after a monitoring period. It was meant to have minimal long-term scientific research activity on the site and was not designed to include non-disposal functions for nuclear waste management (e.g., a research or reprocessing capacity).

The Yucca Mountain repository was designed to have neither long-term scientific research nor a reprocessing capacity on the site.

This combination of features (or lack of features), influences the way observers understand the combination of risks and benefits of the facility. Given the large number of permutations of possible facility design features, in 2011 the NSNP focused on the effects of

two variations in design: combining two centralized, mine-like repositories with either (1) a research laboratory or (2) an SNF reprocessing facility. Note that both alternatives stipulate that the repository would have secure surface storage and would be in compliance with regulatory safety requirements.

When more complete descriptions were provided, there was a moderate increase in support. The deep-geologic mine option received an average initial support of 4.65 on the one (strongly oppose) to seven (strongly support) scale. Fifty-seven percent of the respondents who were presented with this option expressed support, while 19 percent were opposed, and 24 percent were neutral.

Given these starting points, what happens to support for the facility if the repository function is combined with a laboratory and/or a reprocessing facility? To evaluate the effects of a combination of facilities, the following two questions were posed, in random order, in 2011:

What would happen to your level of support if you learned that each of the sites also would contain a national research laboratory for studying ways to more safely and efficiently manage and dispose of nuclear materials?

What would happen to your level of support if you learned that each of the sites also would include facilities

for reprocessing spent nuclear fuel for reuse in generating electricity?

The effects of bundling (combining) a base repository with a hypothetical national research laboratory are shown in Table 1. Changes in support attributable to the addition of the laboratory are shown for those who initially supported, were neutral, or opposed the base facility.

The most striking changes were noted for those who were initially opposed or neutral to siting the facility. Among those who were initially opposed, 42 percent said their support for the repository would increase if it were combined with a national research laboratory. Among those who were initially neutral, support increased to 60 percent.

These findings are consistent with findings of earlier studies showing that modifying facilities in a way that addresses the initial risks—both reducing them directly and providing benefits germane to those risks—is the most effective way to increase the level of acceptance of a facility (Jenkins-Smith and Kunreuther, 2005).

In this case, co-locating an SNF repository with a national research laboratory that would study “ways to more safely and efficiently manage and dispose of nuclear materials” would both reduce the relevant risks and provide high-prestige employment and other economic benefits. Based on the substantial increases

in levels of support, such a facility may be less susceptible to the stigmatizing images that often characterize descriptions of stand-alone repositories.

The effects of combining a repository with a reprocessing facility are shown in Table 2. Again, the changes in support are shown for those who initially opposed, were neutral, or supported each option. As with co-location of a repository with a national research laboratory, co-location of a repository with a reprocessing facility also increased support. Among those who either initially opposed the repository or were neutral,

TABLE 1 Changes in Support for Repositories with Co-located Research Laboratories, 2011

Initial Preference	Support (%) 57	Neutral/Unsure (%) 24	Oppose (%) 19
Support Increased	88	60	42
Support Unchanged	8	34	20
Support Decreased	4	6	38

Source: Herron et al., 2012.

TABLE 2 Changes in Support for Repositories with Co-located Reprocessing Facilities, 2011

Initial Preference	Support (%) 57	Neutral/Unsure (%) 24	Oppose (%) 19
Support Increased	84	51	37
Support Unchanged	10	38	18
Support Decreased	6	11	45

Source: Herron et al., 2012.

nearly half said the addition of the reprocessing capability would increase support for the repository. A smaller percentage said the combination would decrease support. Given the consistent and generally supportive attitudes of most Americans toward reprocessing (as discussed above), the increase in support for repositories co-located with reprocessing facilities is not surprising and could be helpful in informing policies.

The implications are that public acceptance of an SNF repository is sensitive to the overall design attributes of the facility. If it is exclusively for disposal, the perceived risks and associated negative images tend to dominate perceptions (especially when SNF has been designated a “waste”). If the facility is more heterogeneous, that is, it includes design elements that address offsetting risk/benefits (such as a laboratory or reprocessing facility), thus attaching resource value to SNF, prospects for public acceptance improve.

Lessons Learned

In this article, we have described a number of lessons learned from prior experience and social science research on public acceptance of nuclear materials management facilities. Overall, we have learned that public attitudes can inform the policy debate in important ways. In addition, we believe that careful, time-series investigations can continue to provide important guidance for policies and public acceptance of nuclear facility siting.

Acknowledgments

Sandia National Laboratories is a multi-program laboratory operated by Sandia Corporation, a wholly owned subsidiary of Lockheed Martin Company, for the U.S. Department of Energy (DOE) National Nuclear Security Administration, under contract DE-AC04-94AL85000. The opinions expressed in this article are those of the authors and do not necessarily reflect the views or policies of DOE or Sandia.

References

- Bassett, G., H. Jenkins-Smith, R. O'Connor, and C. Silva. 1998. What Have We Learned. Unpublished Research Summary. Available from the authors (hjsmith@ou.edu).
- Easterling, D., and H. Kunreuther. 1993. The Vulnerability of the Convention Industry to the Siting of a High Level Nuclear Waste Repository. Pp. 209–238 in *Public Reactions to Nuclear Waste: Citizens' Views of Repository Siting*, edited by R. Dunlop, M. Kraft and E. Rosa. Durham, N.C.: Duke University Press.
- Elam, M., and G. Sundqvist. 2009. The Swedish KBS project: a last word in nuclear fuel safety prepares to conquer the world? *Journal of Risk Research* 12(7): 969–988.
- Flynn, J., P. Slovic, and C.K. Mertz. 1993. The Nevada Initiative: a risk communication fiasco. *Risk Analysis* 13(5): 497–502.
- Gawande, K., and H. Jenkins-Smith. 2001. Nuclear waste transport and residential property values: estimating the effects of perceived risks. *Journal of Environmental Economics and Management* 42: 207–233.
- Herron, K., and H. Jenkins-Smith. 2006. *Critical Masses and Critical Choices: Evolving Public Opinion on Nuclear Weapons, Terrorism, and Security*. Pittsburgh, Pa.: University of Pittsburgh Press.
- Herron, K., and H. Jenkins-Smith. 2010. *Public Security Perspectives: American Views on Nuclear Weapons, Terrorism, Energy and the Environment: 2009*. Sandia Report SAND2009-8420. Albuquerque, N.M.: Sandia National Laboratories. Available online at <http://crcm.ou.edu/projects/nuclear/>.
- Herron, K., H. Jenkins-Smith, and C. Silva. 2012. *US Public Perspectives on Security: Nuclear Weapons, Terrorism, Energy and the Environment: 2011*. Sandia Report SAND2012-0165. Albuquerque, N.M.: Sandia National Laboratories. Available online at <http://crcm.ou.edu/projects/nuclear/>.
- Hokkanen, P., and M. Kojo. 2003. Ympäristövaikutusten arviointimenettelyn vaikutus päätöksentekoon (Influence of EIA on decision-making). *Suomen ympäristö (Finnish Environment)* 612. Helsinki, Finland: Ministry of the Environment.
- Jenkins-Smith, H., and H. Kunreuther. 2001. Mitigation and benefits measures as policy tools for siting potentially hazardous facilities: determinants of effectiveness and appropriateness. *Risk Analysis* 21: 371–382.
- Jenkins-Smith, H., and H. Kunreuther. 2005. Mitigation and Benefits Measures as Policy Tools for Siting Potentially Hazardous Facilities: Determinants of Effectiveness and Appropriateness. In *Facility Siting and the Management of Legitimate Claims*, edited by S. Lesbirel and D. Shaw. Northampton, Mass.: Edward Elgar Press.
- Jenkins-Smith, H., and K. Herron. 2009. *American Security Perspectives: Public Views on Energy, Environment, Nuclear Weapons and Terrorism: 2008*. Sandia Report SAND2008-8027P. Albuquerque, N.M.: Sandia National Laboratories. Available online at <http://crcm.ou.edu/projects/nuclear/>.
- Jenkins-Smith, H., K. Herron, and C. Silva. 2011. *American Perspectives on Security: Energy, Environment, Nuclear*

- Weapons, and Terrorism: 2010. Sandia Report SAND2011-1686. Albuquerque, N.M.: Sandia National Laboratories. Available online at <http://crcm.ou.edu/projects/nuclear/>.
- Jones, J. 2009. Support for Nuclear Energy Inches to New High. Gallup, Inc. Available online at <http://www.gallup.com/poll/117025/Support-Nuclear-Energy-Inches-New-High.aspx>. Last accessed July 16, 2010.
- Kunreuther, H., and D. Easterling. 1998. The role of compensation in hazardous facility siting. *Journal of Policy Analysis and Management* 15(4): 601–622.
- Lupia, A., and M. McCubbins. 1998. *The Democratic Dilemma: Can Democratic Citizens Learn What They Need to Know?* Cambridge, Mass.: Cambridge University Press.
- OECD-NEA. 2001. *Reversibility and Retrievability in Geologic Disposal of Radioactive Waste: Reflections at the International Level*. Paris: OECD.
- OECD-NEA. 2009. *RWMC Reversibility and Retrievability Project: Phase-2 report*. NEA/RWM(2009)3/REV1. Paris: OECD. 5 March 2009.
- Slovic, P., J. Flynn, and M. Layman. 1991a. Perceived risk, trust and the politics of nuclear waste. *Science* 254: 1603–1607.
- Slovic, P., N. Krause, H. Lappe, and M. Major. 1991b. Risk perception of prescription drugs: report on a survey in Canada. *Canadian Journal of Public Health* 82: S15–S20.
- Slovic, P., M. Layman, and J. Flynn. 1991c. Risk perception, trust and nuclear waste: lessons from Yucca Mountain. *Environment* 33: 6–11, 28–30.
- Yankelovich, D. 1991. *Coming to Public Judgment: Making Democracy Work in a Complex World*. Syracuse, N.Y.: Syracuse University Press.

NAE News and Notes

NAE Newsmakers

Nadine Aubry, Raymond J. Lane Distinguished Professor and department head, Mechanical Engineering Department, Carnegie Mellon University, has been awarded the distinction of **fellow of the American Institute for Aeronautics and Astronautics (AIAA)** for her outstanding work in the field of aerospace, including pioneering contributions to fluid dynamics. Dr. Aubry was inducted at the AIAA Aerospace Spotlight Awards Gala on May 9 at the Ronald Reagan Building and International Trade Center in Washington, D.C. Being named a fellow of AIAA is among the highest honors that can be bestowed upon an aerospace professional.

From the invention of the DNA sequencer during his days at Caltech to the introduction of the first automated DNA sequencer in 1986 and the realization of the Human Genome Mapping Project in 2003, **Michael W. Hunkapiller**, general partner, Alloy Ventures Inc., has been a scientific and industry trailblazer. Under his leadership, industry pioneers Applied Biosystems, Celera, and Applera grew into global giants, contributing to the success of countless biotech companies and researchers expanding the frontiers of genomics and proteomics. For these reasons, BayBio, the Northern California Life Science Association, honored Dr. Hunkapiller on November 3, 2011, with its **2011 Lifetime Achievement DiNA Award**. The award is given in recognition of achievement and honors excellence in the

life sciences industry in Northern California.

Shirley Ann Jackson, president, Rensselaer Polytechnic Institute, has been chosen by the American Association for the Advancement of Science (AAAS) to receive the prestigious **2011 Philip Hauge Abelson Award**. Dr. Jackson was selected for her extraordinary leadership of and contributions to the scientific community, government, universities, industries, and future generations of science and engineering professionals. The award was presented on February 15, 2012, at the AAAS Annual Meeting in Vancouver, British Columbia, Canada.

The winner of the **2012 Arthur C. Clarke Lifetime Achievement Award** is **Vinton G. Cerf**, Chief Internet Evangelist, Google Inc., and co-inventor of the architecture and basic protocols of the Internet. Presented by the Arthur C. Clarke Foundation, the award is given to "an individual, a group or an entity that exemplifies the values and accomplishments of Sir Arthur's life." The **2012 Arthur C. Clarke Innovator Award** was presented to **Pradman Kaul**, president and CEO, Hughes Communications Inc. Mr. Kaul was recognized for sustained leadership in advancing satellite communications. Both awards were presented at a ceremony on April 12, 2012, at Intelsat Headquarters in Washington, D.C.

Richard A. Meserve, president, Carnegie Institution for Science, was elected a **Foreign Member of the Russian Academy of Sciences**

(Section on Radiation Safety, Energy Development, and Environmental Protection). Dr. Meserve has engaged in extensive activities with the Russian Academy over the years on projects undertaken by the U.S. National Academies. The Russian Academy has approximately 250 Foreign Members.

James Monsees, senior vice president, technical director, and principal professional associate, Parsons Brinckerhoff Inc., has received a **Lifetime Achievement Award** from *Tunnels & Tunnelling International* magazine. Dr. Monsees was honored for his extensive contributions to the tunneling industry, both in technical accomplishment and as an inspiration to future tunnelers.

Malcolm R. O'Neill, Assistant Secretary of the Army (ALT), United States Army, has won the **2012 Ronald Reagan Missile Defense Award** for his outstanding support and leadership of the U.S. ballistic missile defense program. Since 2003, the Ronald Reagan Missile Defense Award has been conferred annually on an individual or organization for outstanding support, innovation, and engineering or scientific achievement associated with technologies designed to defend against ballistic missile attack. The award was presented to Dr. O'Neill by the Missile Defense Agency.

ACM, the Association for Computing Machinery, named **Judea Pearl**, professor, Computer Science Department, University of California, Los Angeles, winner of the **2011 ACM A.M. Turing Award**.

Dr. Pearl pioneered developments in probabilistic and causal reasoning and their application to a wide range of problems and challenges. He also created a computational foundation for processing information under uncertainty and developed graphical methods and symbolic calculus that have enabled machines to reason about actions and observations and to assess cause-effect relationships from empirical findings. The Turing Award, widely considered the “Nobel Prize in Computing,” includes a \$250,000 prize. Financial support is provided by Intel Corporation and Google Inc.

The Chemical Engineering Division of the American Society for Engineering Education (ASEE) has awarded the **2012 Lifetime Achievement Award in ChE Pedagogical Scholarship** to **John M. Prausnitz**, professor, Department of Chemical and Biomolecular Engineering, University of California, Berkeley. The award is given in recognition of a sustained career of pedagogical scholarship that has not only led to substantial, innovative change, but has also inspired younger educators to adopt new behaviors that benefit students in

chemical engineering. The award was presented to Dr. Prausnitz at the Chemical Engineering Division Banquet at the 2012 ASEE meeting in San Antonio, Texas, in June 2012.

Alberto Sangiovanni-Vincentelli, professor of electrical engineering and computer sciences, University of California, Berkeley, has been honored by the European Design and Automation Association (EDAA) with the prestigious **EDAA Lifetime Achievement Award** for outstanding contributions to state of the art electronic design, electronic design automation, and testing of electronic systems. EDAA, a non-profit association, works to benefit international electronics design and the design automation community. The award was presented at the plenary session of the 2012 EDAA Conference, held on March 12–16 in Dresden, Germany.

Three NAE members, **David B. Marshall**, principal scientist, Teledyne Scientific Company; **Frieder Seible**, dean, Jacobs School of Engineering, and Zable Professor and Reissner Professor, University of California, San Diego; and **Jeffrey Wadsworth**, president and

chief executive officer, Battelle, have been **elected foreign members of the Chinese Academy of Engineering (CAE)**. CAE is an independent, national organization that honors members of the engineering and technological sciences community of China.

The **National Inventors Hall of Fame** has inducted five NAE members: **David Thompson**, retired, IBM Almaden Research Center, for thin-film magnetic heads for data storage systems; **Barbara H. Liskov**, Institute Professor, Massachusetts Institute of Technology, for innovation in the design of computer programming languages and system design; **C. Kumar N. Patel**, president and CEO, Pranalytica Inc., for the carbon dioxide laser; **Gary K. Starkweather**, retired architect, Microsoft Corporation, for the laser printer; and **Alejandro Zaffaroni**, founder, Alexza Pharmaceuticals Inc., for controlled drug delivery systems. The National Inventors Hall of Fame Inc. is a not-for-profit organization that honors men and women whose technological advances make human, social, and economic progress possible.

NAE Honors 2012 Prize Winners



Left to right: Dr. George H. Heilmeier, Dr. Martin Schadt, Dr. Wolfgang Helfrich, Mrs. Sarah Brody Webb (daughter of Dr. T. Peter Brody, who passed away in September 2011), J. Richard Phillips, M. Mack Gilkeson, and Clive L. Dym. Mrs. Brody Webb accepted the award for her father, Dr. T. Peter Brody.

Traditionally, NAE honors outstanding individuals for significant innovation, leadership, and advances in bioengineering. The 2012 award winners were honored at a black-tie dinner on February 21 at historic Union Station

in Washington, D.C. The recipients of the Charles Stark Draper Prize and Bernard M. Gordon Prize accepted their awards before an audience of more than 250 guests, with NAE President **Charles M. Vest** and NAE Council Chair

Irwin M. Jacobs at the podium. Presenters at this year's ceremony were James D. Shields, president and CEO, Charles Stark Draper Laboratory Inc., and Bernard M. Gordon, chairman, NeuroLogica Corporation.

Charles Stark Draper Prize

George H. Heilmeier, Martin Schadt, Wolfgang Helfrich, and T. Peter Brody were awarded the 2012 Charles Stark Draper Prize “for the engineering development of the liquid crystal display (LCD) utilized in billions of consumer devices.”

The liquid crystal display (LCD) is used by virtually everyone in the modern world on a daily basis to get information from a variety of everyday devices—including calculators, clocks, computer monitors, smart phones, and television screens.

T. Peter Brody, George H. Heilmeier, Wolfgang Helfrich, and Martin Schadt each made substantial contributions to its development.

George H. Heilmeier discovered the dynamic scattering mode (DSM), which resulted in the first operational LCD. Liquid crystals are materials with properties of both liquids and crystals, and DSM allows them to scatter light when voltage is applied. Shortly after Heilmeier's discovery, DSM LCDs could be widely found in watches and calculators.

Taking their cues from Heilmeier's work, Wolfgang Helfrich and Martin Schadt invented the twisted nematic (TN) field effect of LCDs. Unlike DSM, the TN field effect electrically controls the polarization of transmitted light of LCDs. TN requires virtually no power and small electric fields, yet the contrast of light is very large, allowing for short switching from dark to bright and vice versa. Helfrich and Schadt's discovery of TN led to the practical use of LCDs in nearly all flat panel LCD devices.

T. Peter Brody created the active matrix (AM) drive, which enabled an array of new capabilities for LCDs, such as the display

of high-resolution motion pictures combined with fast response, the prerequisites for television. Brody's AM LCD led to LCD advancements

in television, such as color filters and brightness-enhancement films.

Acceptance Remarks by Wolfgang Helfrich



Wolfgang Helfrich

I am speaking to you today because I am the oldest of the three personally present winners of the Charles Stark Draper Prize, but I am not going to speak about the troubles of old age. Instead, I go back in time roughly 45 years to RCA Laboratories, where I had the good luck of being assigned to the liquid crystal group led by George Heilmeyer, the man who introduced liquid crystal electro-optical displays.

My charter back then was to look into the physics of the group's newly invented displays. I suggested

to Heilmeyer that he try twisted nematic, but it was probably too late. His group was already disbanding, and he was looking forward to being a White House Fellow. So, against my original intention, the idea of twisted nematic traveled with me to Basle, Switzerland, where it was finally reduced to practice by Martin Schadt.

It clearly speaks in favor of this country that you invited us Europeans to share the prize with George Heilmeyer and Peter Brody. All of the winners feel very much honored to receive this prestigious award. In the first place, our thanks go to the National Academy of Engineering and to its president, **Charles Vest**. We should not be shy, but thank with joy our nominators and their supporters. We are grateful also to everyone involved in the smooth organization of today's event.

The Academy generously allowed us to invite family, colleagues, and friends. This makes the event a great opportunity for reunions. Let me also address a special word of thanks to my sons-in-law who are taking care of the grandchildren in Germany while our three daughters are here in the audience.

The complicated history of twisted-nematic liquid-crystal displays, from invention to patent and market, has elements of a detective story. This history was first treated in a review article by Hiro Kawamoto and more recently in a book by David Dunmur and Tim Sluckin. The present ceremony is a good occasion to thank these authors—Hiro Kawamoto is, in fact, here—for their painstaking scrutiny in resolving many of the mysteries. There is also a young man among us who just got his Ph.D. with a thesis on the history of liquid crystals at RCA Laboratories.

As the winners of this year's Draper Prize, we can be proud of our work. At the same time, we are aware of the enormous amount of engineering it took to make liquid-crystal electro-optical displays the success they are today. Peter Brody and Martin Schadt took part in this engineering development.

We all consider ourselves fortunate to have been involved in the beginnings of a technology that, in our own lifetime, has become ubiquitous.

Bernard M. Gordon Prize

The 2012 Bernard M. Gordon Prize was awarded to Clive L. Dym, M. Mack Gilkeson, and J. Richard Phillips “for creating and disseminating innovations in undergraduate engineering design education to develop engineering leaders.”

The Harvey Mudd College (HMC)

Engineering Program combines hands-on, experience-based learning, exemplified by its innovative Engineering Clinic, with formal design instruction. The goal is to create engineering leaders. The innovative Engineering Program, which also strongly emphasizes

writing and presentations, has had a profound influence on other institutions and curricula. The HMC curriculum also includes opportunities for teaching K–12 students and a leadership strategy course in which students meet and get to know highly successful business people.

Acceptance Remarks by Clive L. Dym



Clive L. Dym

Good evening, Mr. Gordon, members of the Gordon Prize committee, Dr. Vest, members of the National Academy, ladies and gentlemen.

First and foremost, on behalf of Mack Gilkeson and Rich Phillips and myself, thank you. The Bernard M. Gordon Prize for innovation in engineering and technology is unique in the world in its focus and magnitude, and the honor you confer on us is truly exceptional.

Harvey Mudd College (HMC) was founded as a “liberal arts college of science and engineering” in

1955. Shortly thereafter, HMC’s Engineering Department set out on an innovative path in engineering education, creating a tradition and ethos that survive and prosper as we speak. A new paradigm was established that recognizes the value of experiential learning, the importance of engagement with industry, the centrality of design, and the values of professional practice. The program started with a freshman projects course and continued with our famed Engineering Clinic. Now, almost 60 years later, our students have completed 1,000 Engineering Clinic projects and more than 150 first-year design projects.

But the real story is not just the number of Clinics and first-year design projects, nor is it the Mudd Design Workshops that came much later. The real story is the institutional commitment to a set of ideas that have cast engineering education in a new light. Thus, while balancing a growing tradition against the need to embrace change in a rapidly changing world, a small undergraduate institution has created a model engineering curriculum, and at the same time, has graduated a (small) host of talented engineers.

The real story developed because the Engineering Department is part of a remarkable institution that also embraced the creative tension between tradition and change, an institution of faculty and students, of staff and administration, throughout Harvey Mudd College.

You have already heard about Mack and Rich and me. We also want to recognize and remember two other innovative collaborators, now deceased: Jack Alford was the co-creator of Engineering Clinic, and Ted Woodson was our first formally titled Director of Engineering Clinic.

The conferral of the Gordon Prize on Mack, Rich, and me will encourage our HMC engineering colleagues to continue our endeavors at home while preaching our sermon to an increasingly receptive choir. Three of those colleagues are here tonight, Zee Duron (HMC ’87), Pat Little, and Liz Orwin (HMC ’95), as is our president, Maria Klawe.

Finally, to the Academy, to our colleagues, and to the families that have supported us over the years, thank you.

Report of the Foreign Secretary



Venky Narayanamurti

As you may know, I assumed the post of NAE Foreign Secretary in July 2011. In this post, I hope to continue to build on the activities of my predecessors in an increasingly globalized world. The emergence of new economic powerhouses in Asia and Latin America and the need to find solutions to global challenges (such as energy and water, climate change, engineering resilient systems, etc.) have made the importance of engineering in international cooperation very clear. I hope in the coming years I can engage more with both our For-

eign Associates and the membership at large in building capacity in NAE to work on these global problems.

An important program for establishing links between NAE and engineers around the world has been the bilateral Frontiers of Engineering workshops, which the NAE Program Office has nurtured for many years. I had the privilege of attending three of those workshops in the past year, one with the European Union (in Irvine, California, in November 2011), one with India (in Arlington, Virginia, in February-March 2012) and one with Germany (in Potsdam, also in March 2012). These workshops bring together promising young researchers in a variety of disciplines to address challenges that require multi-disciplinary solutions. The most recent meeting in Potsdam, for example, highlighted work on microrobotics for hazardous environments, nano-materials for environmental solutions, energy systems, and implantable electronics for human health.

As Foreign Secretary, I also work closely on NRC activities with my counterparts in the NAS and IOM. One ongoing activity is an initiative funded by a grant from the Gates Foundation to develop capacity in African academies of science. I attended a board meeting of ASADI (African Science Academy Development Initiative) in Uganda in November 2011. This was my first trip to Africa, and it was clear to me from the ASADI meeting that our African colleagues are eager to enhance the role of science, engineering, and medicine in matters of public policy in their emerging economies.

I know many of you also participate in ongoing activities in the international arena. I would welcome hearing your suggestions for how NAE might increase its reach and influence on the international stage.

A handwritten signature in cursive script that reads "Venky Narayanamurti".

Venky Narayanamurti

NAE Chair, Home Secretary, and Councillors Elected



Charles O. Holliday, Jr.



Thomas F. Budinger



Corale L. Brierley



Arnold F. Stancell



Anita K. Jones



Richard H. Truly



Irwin M. Jacobs



Robert F. Sproull



G. Wayne Clough

This spring, NAE elected a new chair, reelected its home secretary, reelected two incumbent councillors, and elected two new councillors. All terms begin July 1, 2012.

The new NAE chair, elected to a two-year term, is **Charles O. Holliday, Jr.**, chairman of Bank of America and retired chairman of the board and CEO of E.I. DuPont de Nemours and Co. **Thomas F. Budinger**, professor of the graduate school at the University of California, Berkeley, and faculty senior scientist at the E.O. Lawrence Berkeley National Laboratory, was reelected to a four-year term as NAE home secretary.

Corale L. Brierley, principal

of Brierley Consultancy LLC, and **Arnold F. Stancell**, retired vice president of Mobil Oil and Turner Professor of Chemical Engineering, Emeritus, at the Georgia Institute of Technology, were reelected to three-year terms as councillors.

Two new councillors, also elected to three-year terms, are **Anita K. Jones**, University Professor Emerita at the University of Virginia, and **Richard H. Truly**, retired vice admiral in the United States Navy and retired director of the National Renewable Energy Laboratory.

On June 30, 2012, **Irwin M. Jacobs**, director of Qualcomm Incorporated, completed two terms of service as NAE chair, the

maximum allowed under the NAE bylaws. **Robert F. Sproull**, retired vice president and director of Sun Labs at Oracle, completed six continuous years of service as councillor, the maximum allowed under the NAE bylaws. **G. Wayne Clough**, secretary of the Smithsonian Institution, completed four continuous years of service as councillor; Dr. Clough was ineligible for a continuing three-year term because it would have exceeded the maximum six years of continuous service allowed under NAE bylaws. Drs. Jacobs, Sproull, and Clough were recognized in May for their distinguished service and other contributions to the NAE.

2012 German-American Frontiers of Engineering Symposium Held in Potsdam, Germany



Poster session during the symposium. Photo courtesy of the Alexander von Humboldt Foundation.

The 2012 German-American Frontiers of Engineering (GAFOE) Symposium was held on March 29–31 at the Steigenberger Hotel Sans Souci in Potsdam, Germany. GAFOE, the “oldest” bilateral Frontiers of Engineering program, was initiated in 1998. NAE’s partner in organizing GAFOE events is the Alexander von Humboldt Foundation. The symposium organizing committee was co-chaired by NAE member **Cynthia Barnhart**, associate dean for academic affairs, School of Engineering, and professor of civil and environmental engineering at the Massachusetts Institute of Technology; and Peter Moser, head of new technology R&D at RWE Power AG.

Modeled on the U.S. Frontiers of Engineering Symposium, the GAFOE Symposium brought together outstanding engineers, ages 30 to 45, working in German and U.S. companies, universities, and government. Like its U.S. counterpart, the goal of the meeting was to

bring together emerging engineering leaders in a venue that facilitates interdisciplinary transfers of knowledge and methodologies from a variety of areas of engineering. In bilateral symposia, there is an added dimension of building cooperative networks of younger engineers across national boundaries. The four topics at the GAFOE meeting this year were robotics for hazardous environments, nanomaterials and the environment, energy storage, and implantable electronics.

In the introduction to the first session, Robotics for Hazardous Environments, the organizers provided an overview of the current state-of-the-art in field robotics, identified short- and long-term scientific and technological challenges, and outlined a vision for the future in which robots will assist, or even replace humans in hazardous environments. Presentations covered robotic navigation; probabilistic reasoning methods paired with optimization and machine learning techniques for

developing robust robotic systems; system design, mobile manipulation, and human-machine interaction in challenging environments; and autonomous robotic systems for Mars exploration.

The organizers of the session on Nanomaterials and the Environment brought together a panel to discuss the benefits and consequences of nanomaterials in the environment. The first two talks focused on examples of the benefits of nanotechnology in engineered materials and devices. The third and fourth speakers described some of the unintended consequences of nanomaterials that are allowed to interact with the environment and the challenges of assessing these consequences. Specifically, the speakers focused on using nano-enabled products to produce clean water; nanoparticle aerosols in workplace environments; life-cycle analysis, exposure, release, and fate of nanomaterials in aquatic environments; and issues of ecotoxicology that may arise when nanomaterials and organisms interact, possibly causing unintended consequences throughout the food chain.

Energy storage systems can decouple the production and consumption of thermal or electrical energy, thereby facilitating flexibility in the supply and demand of energy and making it possible to power mobile applications. For example, as renewable energy becomes more important, the need for storing energy from intermittent sources such as wind power has renewed the focus on energy storage technologies. This topic touches on a great many

areas of engineering, including grid integration, electrical vehicle range, charging/storing efficiencies, and issues related to life-cycle and degradation. Speakers in this session discussed the energy storage systems necessary for a successful electricity grid, a methodology for assessing the potential value of different grid-based energy storage technologies, energy storage for sustainable automotive transportation, and thermal energy storage for dispatchable power generation with a focus on solar thermal power plants.

The organizers of the Implantable Electronics session noted that, since the implantation of the first cardiac pacemakers in the 1960s, technical progress in the field of microelectronics and micromachining has led to the widespread use of implantable electronics in various biomedical applications. However, many technical challenges remain, such as biocompatibility, the need for batteries that can store large amounts of energy in small volumes, and extending implant functionality for

closed-loop systems with integrated sensors. The speakers provided an overview of state-of-the-art implantable electronics and insights into anticipated developments. The first presentation focused on new materials and fabrication technologies for implantable neural electrode arrays. The next speaker described advances in implantable electronics for neural stimulation and recording for cochlear implants, deep brain stimulation, and retinal prosthetics. The third speaker's topic was the development of integrated, autonomous medical microsystems for monitoring and/or controlling physiological parameters; these devices, which were originally intended for interfacing with the nervous systems of moths, are now being translated for human applications. The final talk was on Argus[®] II, a 60-electrode neural interface implant that restores a degree of vision to subjects with retinitis pigmentosa.

As is typical at bilateral FOE meetings, a poster session was held on the first afternoon at which

attendees presented their research or technical work to each other. The posters, which remained on display throughout the symposium, prompted many conversations that continued throughout the meeting. On the second afternoon, a bus tour of Potsdam took attendees to the city's famous parks, palaces, and renovated villas, as well as the notorious Glienecke Bridge over the Havel River, the former border between U.S.-occupied West Berlin and Soviet-occupied Potsdam, which was in East Germany during the Cold War.

Funding for the meeting was provided by the Alexander von Humboldt Foundation, The Grainger Foundation, and the National Science Foundation. The next GAFOE Symposium will be held in 2013 in the United States. Cynthia Barnhart and Peter Moser will continue to serve as co-chairs.

For more information about GAFOE, contact Janet Hunziker in the NAE Program Office at (202) 334-1571 or jhunziker@nae.edu.

4th Indo-American Frontiers of Engineering Symposium Held in Arlington, Virginia



Participants in the fourth Indo-American Frontiers of Engineering Symposium. Photo courtesy of Lockheed Martin.

The fourth Indo-American Frontiers of Engineering (IAFOE) Symposium was held on March 1–3. This biennial symposium series—one of five joint FOE programs—was inaugurated in 2006. The Indo-U.S. Science and Technology Forum (IUSSTF) is NAE’s partner in this endeavor.

NAE member **Lisa Alvarez-Cohen**, Fred and Claire Sauer Professor and chair of the Department of Civil and Environmental Engineering at the University of California, Berkeley, served as U.S. co-chair. Upadrasta Ramamurty, professor of materials engineering at the Indian Institute of Science in Bangalore, was Indian co-chair. The event was hosted by Lockheed Martin at the Hyatt Regency Crystal City in Arlington, Virginia.

Like other bilateral FOE events, this meeting brought together approximately 60 engineers, ages 30 to 45, from U.S. and Indian universities, companies, and government labs for a 2-1/2-day meeting during which leading-edge developments in four engineering fields were discussed: engineering large infrastructure for natural hazards; engineering at the interface with science; intelligent transportation systems; and technology enablers for advances in aerospace materials. Each session included presentations by two Indian and two U.S. participants.

The session on Engineering Large Infrastructure for Natural Hazards was inspired by recent events, such as the 2011 Tohoku earthquake and tsunami and other reminders of the importance of building environ-

ments that can withstand natural hazards. In the last few decades, significant progress has been made in hazard assessment and hazard-resistant design, as well as in understanding and assessing related risks. Presentations focused on deterministic and probabilistic approaches in modern hazard assessments, performance- and risk-based engineering approaches to seismic safety, the philosophy of risk and reliability engineering, and issues specific to nuclear power plant structures in India.

The second session, Engineering at the Interface with Science, focused on how engineering and science can be mutually enriched through interaction, especially the implications for technology. The design and manipulation of physical/chemical materials and biological

materials with desirable properties, as well as the emerging field of synthetic biology, are examples of areas in engineering that interface with biology, physics, and chemistry. The speakers covered soft modes and related phenomena in materials, engineering the microstructure of semi-crystalline polymers, a new approach to delivering active forms of proteins to specific cells and organs in living organisms using biodegradable nano-capsules, and programming cellular behavior with RNA controllers.

The topic for the next session was Intelligent Transportation Systems (ITS), systems that use information technology to create effective transportation operations. The major focus was on underlying technological innovations and fundamental challenges confronting ITS. The goal was to explore how ITS is being used to improve surface transportation in a variety of urban environments and how wireless communications can improve safety and efficiency. Talks in this session included an overview of the U.S. Federal Highway Administration Connected Vehicles Program, specific infrastructure applications of wireless communications, how ITS is being used to model and control traffic in Indian urban areas with heterogeneous conditions, and data collection and surveillance challenges to providing advanced public transportation and traveler information systems in India.

The final session of the meeting was on Technology Enablers

for Advances in Aerospace Materials. The leaders of this session noted that, despite the importance of materials technology to aerospace systems, the introduction of new materials is becoming increasingly infrequent because of the cost and time involved in developing them and the inherent risk aversion of aerospace system designers. Recently, the focus has shifted to the development of adjacent technologies, such as joining, coatings, life prediction, and computational modeling and simulation to improve the performance of existing materials at significantly lower cost and in a much shorter time. The speakers highlighted recent advances in adjacent technologies that are impacting modern aerospace materials. Presentations focused on integrated computational materials engineering, which enables the optimization of materials, manufacturing processes, and component design long before components are fabricated by integrating computational processes into a holistic system; the design and deployment of nanostructural alloys; challenges in developing new coatings to improve the performance of existing aerospace materials; and the latest trends in the joining of aerospace materials.

There were two dinner speakers during the conference. On the first night, John Evans, corporate vice president for technology and innovation at Lockheed Martin, spoke about leadership in innovation, which he defined as “repeatedly generating economic surprise.”

Two factors, he said, are particularly important to becoming a leader in innovation: effective allocation of resources in the face of extreme uncertainty and the creation of processes and cultures that encourage and support appropriate allocation decisions.

Subra Suresh, director of the National Science Foundation (NSF), who spoke on the second night, described NSF’s mission, its tackling of global and national challenges, and its new initiatives, such as Partnerships for Enhanced Engagement in Research, Innovation Corps, and the NSF Career Life Initiative.

A poster session on the first afternoon provided an opportunity for all participants to talk about their research or technical work. On the second afternoon, the group toured the Lockheed Martin Global Vision Center where docents explained exhibits in the Energy Solutions Center, the Space Experience Center, and the Tactical Solutions Center.

Primary support for the IAFOE Symposium was provided by Lockheed Martin and IUSSTF. The next symposium in the IAFOE series will be held in March 2014 in India.

For more information about FOE series or to nominate an outstanding engineer for participation in a future FOE meeting, contact Janet Hunziker in the NAE Program Office at (202) 334-1571 or jhunziker@nae.edu.

The Grainger Foundation Frontiers of Engineering Grants for the Advancement of Interdisciplinary Research

Two Grainger Foundation Frontiers of Engineering Grants of \$30,000 each have been awarded to participants in the NAE 2011 U.S. Frontiers of Engineering (USFOE) Symposium.

Ali Khademhosseini (Harvard Medical School) and Aydogan Ozcan (University of California, Los Angeles) will receive a Grainger Grant to support the demonstration of a computational lens-free imaging platform for high-throughput screening of cells. This platform will enable real-time monitoring of cells in an engineered environment and provide a lower cost, more effective mechanism for drug discovery and biological science experiments.

The second Grainger Grant

was awarded to Michelle Pivonelli (University of Southern California) and Roman Stocker (Massachusetts Institute of Technology) for the development of nanophotonic tools for measuring the motile behavior of microorganisms in response to applied stress. By examining the movement of microorganisms as they consume energy, this research will advance understanding of ocean ecosystem dynamics, bacteria-borne diseases, and other subjects of interest.

Frontiers of Engineering is an NAE program that brings together outstanding early-career engineers from industry, universities, and government to discuss pioneering technical work and leading-edge research

in various engineering fields and industry sectors. The goal is to facilitate interactions and exchanges of techniques and approaches and to facilitate networking among the next generation of engineering leaders. The Grainger Foundation Frontiers of Engineering Grants provide seed funding for USFOE participants working at U.S.-based institutions to enable them to pursue important new interdisciplinary research and projects stimulated by USFOE symposia.

The Grainger Foundation, an independent, private foundation based in Lake Forest, Illinois, was established in 1949 by William W. Grainger, founder of W.W. Grainger, Inc.

NAE Regional Meetings



Charles Vest, NAE president, Umesh Mishra, NAE member and UCSB professor of electrical and computer engineering, and NAE member David Auston, executive director, UCSB Institute for Energy Efficiency, converse during a break at the symposium.

Regional Meeting on Energy Efficiency and Sustainability

The University of California, Santa Barbara (UCSB) College of Engineering hosted the NAE regional meeting and symposium on Energy Efficiency and Sustainability on March 22, 2012. The symposium featured six presentations by renowned university and industry researchers on advances in energy efficient technology and materials.

UCSB Chancellor **Henry Yang** gave the campus welcome and introduced NAE President **Charles M. Vest**. In his opening remarks, Dr. Vest expressed his hope that the symposium would convey the importance of research in energy efficiency for companies and nations to continue to grow economically.

Session I

The first presentation, "Heterostructures for (almost) Everything," introduced by **Alan Heeger**, Nobel

laureate in chemistry and UCSB professor of physics and materials, was given by **Herbert Kroemer**, Nobel laureate in physics and UCSB professor of electrical and computer engineering and of materials. Dr. Kroemer described early work on the creation of an efficient light-emitting device. His research on semiconductor heterostructures, he explained, provided the foundation for semiconductor lasers as well as for high-speed and opto-electronics research. His work also influenced research on LEDs and solar cells, technologies that were the subjects of the next two presentations.

In "Silicon Photovoltaics: Accelerating to Grid Parity," **Mark Pinto**, executive vice president at Applied Materials and general manager of Energy and Environmental Solutions, described improvements to the crystalline silicon photovoltaic cell (cSi PV). He explained how market forces and improvements

in technology are driving down the cost of solar energy. By 2020, he said, 98 percent of the world population will have PV, because approximately 78 countries will be at grid parity, which is accelerating worldwide as a result of the explosive economics driving down the price of cSi PV and, therefore, driving up demand. The real revolution in PV electricity, he said, is in building smaller and better cells, an area in which the manufacturers and distributors of solar-powered systems have exceeded expectations.

Steven DenBaars, professor of materials and co-director of the Solid-State Lighting and Energy Center (SSLEC) at UCSB, focused on LEDs in his talk, "Energy Savings Potential of LEDs for Energy Efficient Lighting and Future Research Directions in LEDs." Dr. DenBaars noted that the efficiency of LED bulbs could potentially lower energy consumption from lighting by 46 percent or more by 2030. In the next five years, he said, the cost of an LED light bulb will drop from about \$40 to \$3. Thus, LED technology is approaching the curve of economic viability as its efficiency improves. He also described future trends in LED research, such as a new approach with a red/green/blue active layer and gallium nitride (GaN) laser diodes. GaN technology, he explained, could be used for many more applications than lighting. "With gallium nitride, we believe we can get down to very low wavelengths for UV, which can be used to purify water and thus realize enormous energy savings." Ultimately, LED technology could save the United States

\$250 billion a year in cumulative energy costs.

Session II

Jim Dehlsen, executive chairman of the board of directors of Ecomerit Technologies LLC, opened the second session with “Emerging Marine Hydrokinetic Technology,” a talk on how business innovation contributes to new energy technologies. Dr. Dehlsen traced the development of the Aquantis C-Plane, an underwater turbine for harnessing hydrokinetic power from ocean currents. To build the Aquantis, his team used techniques learned from the design of wind turbines, and thus developed a “mature” technology for ocean engineering. One potentially significant, still untapped area for underwater turbines is the Gulf Stream off the Florida coast. By 2020, the potential contribution of marine kinetic energy is estimated to be about 15 to 20 percent of total energy output.

John Bowers, director of the Institute for Energy Efficiency and UCSB professor of electrical and computer engineering, focused on how data centers can be made more efficient through photonics. In “Energy Efficient Communication and Computing,” Dr. Bowers illustrated how optical communications for microscale processors could be scaled up to the macroscale. In a data center, he said, photonics can add speed and power by offering low-power, fast optical switches through CMOS technology. Bringing the photonic interface closer to the processor chip, or even onto the processor chip, he explained, can reduce the input/output power requirement and increase input/output capacity. “If we can succeed in terabit per second connectivity on

a chip through photonic integration on silicon, then efficient chip-to-chip communication can solve the capacity and power limits in data centers and super computers,” he said. “We need lasers on silicon chips that are efficient and use less than 1 picojoule per bit.”

The final presentation, “High Efficiency Power Conversion Using Gallium Nitride: The Next Semiconductor Revolution,” was given by **Umesh Mishra**, UCSB professor of electrical and computer engineering, who described forthcoming solutions to the inefficiency problems of power conversion. “There is a ‘hidden tax’ on electricity,” he said. “In the United States, power conversion loss comes at an economic cost of \$40 billion, the equivalent of 318 coal power plants.” Dr. Mishra noted that the amount of energy that could be saved by eliminating the need to convert voltages for laptops and other devices is greater than all the energy generated from wind and solar power in the United States. One solution, he said, was using GaN-based circuits to shrink circuits, and thereby reduce energy waste.

Rod Alferness, Richard A. Auhl Professor and dean of the UCSB College of Engineering, delivered closing remarks and thanked the members of NAE for attending. For more information and photos from the symposium, visit <http://www.engineering.ucsb.edu/NAE2012/>.

Symposium on Government-University-Industry Partnerships in Regional Innovation and Entrepreneurship

Today’s knowledge economy depends on the translation of knowledge into value through innovative

thinking and entrepreneurial action, and research university communities have the largest assembly of assets for innovation and entrepreneurship. On April 18, NAE held its first regional meeting in Greater Washington, D.C., to explore the intrinsic partnership of universities, industry, and government in innovation and entrepreneurship.

The event began with welcoming remarks by Wallace Loh, president, University of Maryland, **Charles Vest**, president, NAE, and **C.D. (Dan) Mote Jr.**, Regents Professor, University of Maryland. Each of the two sessions that followed featured a plenary speaker and a moderated panel of experts from government, academia, and industry. The topic of the first session was “Government-University-Industry Partnerships in Regional Innovation and Entrepreneurship: What Works and What Doesn’t?” The focus of the second session was on “Educating Next-Generation Innovators and Entrepreneurs: Expanding beyond Business, Science and Engineering.”

The first plenary speaker, Kevin Plank, founder, president, CEO, and chairman of Under Armour Inc., opened the session on partnerships. This was followed by a panel discussion. Panelists were Patrick Gallagher, under secretary of commerce for standards and technology and director, National Institute of Standards and Technology; Sudhakar Kesavan, chairman and CEO, ICF International; Robert Fischell, chairman, Fischell Biomedical and Angel Medical Systems; and Thomas Scholl, general partner, Novak Biddle Venture Partners.

The panel moderator, Allan Will, president, CEO, and chairman, EBR Systems Inc., began the discussion with a question: “What

facilitates success in government-university-industry partnerships for venture creation?" The panelists agreed that *people*—great leadership, taking the time to learn about each other, and ensuring that the right people are in the right roles—are fundamental to successful ventures. The factors that make for successful *partnerships* must include a common value proposition and compelling goals; agreement on roles, contributions, and expectations; agreement on the decision-making structure and process; and a willingness to be unconventional. Successful *operations* require recognizing the consequences of inaction; being willing to compromise to create "wins"; iterating continually; having effective policies for intellectual property; and addressing competitive markets. Finally, *success*, they said, requires that broad impacts take precedence over pure monetization. Success, they concluded, should be celebrated and publicized enthusiastically.

The panel then turned to the converse question: "What impedes success in government-university-industry partnerships for venture creation?" The same elements were again crucial: *people*, *partnerships*, *operations*, and *success* can also lead to adverse effects. Poor and/or indecisive leadership, adversarial relationships, and mistrust are significant deterrents to successful ventures. Some of the most difficult challenges to overcome may be

a culture of inaction; fear of making mistakes; allowing lawyers to make business decisions; not removing obstacles to success promptly; being subject to overly cautious regulatory agencies; demanding perfection rather than pursuing iterative successes; allowing bureaucracy to take over; creating licensing terms that stifle success (e.g., not appreciating that different technologies/stages/company types require different licensing agreements). Finally, complications ensue when partners do not have a common measure of success.

The second session began with a plenary address by Philip Weilerstein, executive director, National Collegiate Inventors and Innovators Alliance (NCIIA). He described the creation of an ecosystem for innovation and entrepreneurship that culminates in commercialization. The panelists included Holden Thorp, chancellor, University of North Carolina at Chapel Hill; Thomas Miller, executive director, Entrepreneurship Initiative, North Carolina State University; James Green, director, Entrepreneurship Education and Hinman CEOs Program, University of Maryland; and David Baggett, founder and president, Arcode.

Following the panelists' remarks, Dean Chang, director, Mtech Venture Programs, University of Maryland, moderated a discussion on teaching entrepreneurship. The

panelists agreed that educational models for innovation and entrepreneurship must embrace not just business students but students in all areas of study. In addition, because program requirements leave little room for new courses, the best way to reach students is to embed the teaching of entrepreneurship into existing curricula.

Experiential learning, the panelists agreed, is a key factor in removing barriers and encouraging learning and should be introduced whenever possible—in formal classes, "incubators," and informal settings. Experiential learning inspires creativity and out-of-the-box, often unconventional approaches to problem solving. The panelists also agreed that vision and passion for problem solving are mandatory for success. To bring down the barriers to pursuing innovation, standardized "sign and innovate" intellectual property agreements should be in place, and diversity among entrepreneurs should be strongly supported. Finally, failures should be considered opportunities for learning. "Failure teaches budding entrepreneurs important lessons."

The symposium website, <http://www.eng.umd.edu/html/nae/index.html>, includes links to the meeting summary, speaker biographies, and a webcast of the entire event.

“Making Value,” an NAE Workshop

On June 11–12, NAE convened a workshop on “Making Value: Integrating Manufacturing, Design, and Innovation to Thrive in the Changing Global Economy.” The one and one-half day meeting brought together approximately 50 invited experts to explore future directions in manufacturing, design, and innovation and their implications for U.S. jobs and economic performance. NAE members on the steering committee were **Lawrence D. Burns** (chair), professor of engi-

neering practice at the University of Michigan, **Nicholas M. Donofrio**, IBM Fellow Emeritus, and **Jonathan J. Rubinstein**, former executive chairman and CEO of Palm Inc.

A principal theme throughout the workshop was that “making things” is only one component part of “making value.” Manufacturers are increasingly focusing on the complete experiences of their customers—not only physical products, but also non-physical content (such as software) and services.

The workshop was part of a new NAE initiative on the interface of manufacturing, design, and innovation, directed by senior program officer Katie Whitefoot. The goal of the initiative, which will include a portfolio of activities, such as workshops, symposia, and consensus studies, is to identify and analyze exemplary business practices and inform the national debate on manufacturing and innovation policies.

2nd USA Science and Engineering Expo

NAE recently participated in the second USA Science and Engineering Expo at the Walter E. Washington Convention Center in downtown Washington, D.C., the largest celebration of science and engineering in the United States. The event featured more than 3,000 hands-on activities and 150 performances designed to appeal to visitors of all ages and provide a wide variety of ways to explore how science and engineering influence our lives. Exhibits were organized into tracks based on NAE’s Grand Challenges for Engineering: 14 Game-Changing Goals for the 21st Century (www.engineeringchallenges.org).

NAE partnered with students at the University of Texas at El Paso to

develop a Grand Challenges mobile application passport concept for the Expo. The mobile app, available for use with Apple or Android devices, was designed to encourage exhibitors to learn about the Grand Challenges. Passport participants collected digital stamps by scanning QR codes on Grand Challenge-themed signs at exhibits. Users who scanned at least 10 QR codes from different Grand Challenges tracks were eligible for a prize drawing, sponsored by IBM. There were four winners each day. People could also participate using physical stamps, and the passport concept was prominently displayed on the Expo map.

NAE also organized a stage presentation at the Expo called,

“Mixed Messages: Communicating Complexity in a Crisis.” During the presentation, the audience became witnesses and participants in a mock emergency situation that unfolded in a virtual world created by the University of Maryland Center for Advanced Transportation Technology Laboratory. The presentation included a discussion with WTOP Radio traffic reporter Bob Marbourg, EPA environmental engineer Sharon Kenny, and University of Maryland fire protection engineer Peter Sunderland on the critical role of scientists and engineers in communicating effectively with the public during an emergency.

Ambitious Fundraising Goals for NAE's 50th Anniversary in 2014

In 2014, NAE will celebrate its 50th anniversary. Since 1964, NAE has not only advised government on matters of technology and engineering, but has also expanded its purpose to include spreading the message of engineering to students, parents, educators, policy makers, and the general public to ensure continuing American progress and competitiveness. Past accomplishments spearheaded by NAE members include influential projects and studies, such as *Rising Above the Gathering Storm*, *America's Energy Future*, and the recent report, *Macondo Well Deep-water Horizon Blowout*.

With an eye to the future, NAE has launched *Celebrating 50 Years of Engineering Leadership and Service*, a 50th anniversary fundraising effort. By expanding funding, NAE can reach its 50th anniversary with resources that will help the engineering community address the Grand Challenges facing our society and our world, turn complex technological questions into opportunities for innovation and improvement, and maintain NAE's position as a national voice

for engineering. Between now and December 2014, NAE invites all of its friends, and especially its members, to help celebrate 50 years of accomplishment and launch the next 50 years of NAE's service to the nation.

In addition to ensuring long-term stability, NAE hopes this fundraising effort will be an opportunity for members to help NAE. This would mean not only seeking financial contributions, but also listening to the ideas and concerns of members and others who want to help NAE reach its 50th anniversary goals:

50 Percent Participation Rate among Members

This goal, the cornerstone of our 50th anniversary fundraising effort, embodies the inclusive spirit of our philanthropic community.

50 New Members of the Golden Bridge Society

Our Golden Bridge Society recognizes NAE members and friends whose cumulative giving totals \$20,000 to \$99,999.

50 New Members of the Heritage Society

The Heritage Society recognizes members and friends who have thoughtfully included gifts to NAE in their long-term financial plans.

50 Leadership Gifts

We encourage members, friends, corporations, and foundations to consider making a Leadership Gift of \$50,000 to \$1 million or more.

50 New Members of the Einstein Society

The Einstein Society recognizes NAE members and friends whose cumulative giving totals \$100,000 or more.

If you are interested in becoming involved in the 50th anniversary fundraising effort, please contact Radka Nebesky, Senior Director of Development, at 202-334-3417 or Rnebesky@nae.edu.

New NAE Publications

Making Things: 21st Century Manufacturing and Design: Summary of a Forum. More than two decades ago, a commission of 17 MIT scientists and economists released *Made in America*, a report that opened with a memorable phrase, “To live well, a nation must produce well.” Is this still true? Can the United States remain a preeminent nation while other countries make the products that were once made in America? These questions were at the heart of the discussion during “Making Things: 21st Century Manufacturing and Design,” a forum held during the 2011 NAE Annual Meeting. In a wide-ranging conversation, seven leaders of business, government, and academia explored various aspects of manufacturing and design and outlined the many opportunities, and responsibilities, for engineers in manufacturing. This report provides a summary of the discussions during the forum, a forum agenda, and short bibliographies of the participants.

NAE members on the panel were **Craig R. Barrett**, retired CEO and chairman of the board, Intel Corporation; **Rodney A. Brooks**, Panasonic Professor of Robotics (Emeritus), Massachusetts Institute of Technology; **Lawrence D. Burns**, professor of engineering practice, University of Michigan, and retired vice president, R&D and Strategic Planning, General Motors Corporation; and **David M. Kelley**, Donald W. Whittier Professor of Mechanical Engineering, Stanford University. Paper, \$27.00.

Frontiers of Engineering 2011: Reports on Leading-Edge Engineering from the 2011 Symposium. The practice of

engineering is continually changing. To thrive in this environment, engineers must be able to work on interdisciplinary teams. Cutting-edge research is being conducted at the intersections of engineering disciplines, and successful researchers and practitioners must be aware of developments and challenges in areas that may not be familiar to them. At the 2011 U.S. Frontiers of Engineering Symposium, 100 mid-career engineers had an opportunity to learn from their peers about pioneering work in many areas of engineering. This volume highlights the presentations at the 2011 symposium, which addressed four general topics: additive manufacturing, semantic processing, engineering sustainable buildings, and neuro-prosthetics. The summaries and papers in this annual collection provide an overview of the challenges and opportunities in these fields of inquiry and communicate the excitement of discovery and interaction among the symposium participants.

NAE member **Andrew M. Weiner**, Scifres Distinguished Professor, Purdue University, chaired the symposium organizing committee. Paper, \$45.00.

Global Navigation Satellite Systems: Report of a Joint Workshop of the National Academy of Engineering and the Chinese Academy of Engineering.

The Global Positioning System (GPS), which has revolutionized the measurement of position, velocity, and time, has rapidly evolved into a worldwide utility. Today, more than a billion receiver sets provide enormous benefits to humanity, such as improved safety, higher productivity,

and widespread convenience. This report summarizes a joint workshop on global navigation satellite systems (GNSS) held by the U.S. National Academy of Engineering and the Chinese Academy of Engineering on May 24–25, 2011, in Shanghai, China. NAE President Charles M. Vest opened the workshop with these words: “We have one world, and only one set of global resources. It is important to work together on satellite navigation. Competing and cooperation are like Yin and Yang. They need to be balanced.”

This workshop report covers the objectives of the workshop: improving interoperability and interchangeability for all civil users; collaborative efforts to counter the global threat of inadvertent or illegal interference to GNSS signals; and new applications for GNSS with an emphasis on productivity, safety, and environmental protection.

The overall goal of the workshop was to promote technical and policy-related cooperation between the United States and China to benefit both countries and GNSS users worldwide. The workshop presentations include relevant engineering/technical content; are of mutual interest to the peoples of both countries; stress the need for GNSS availability, accuracy, integrity, and continuity; and suggest topics for further action and discussion.

NAE members **Bradford W. Parkinson**, Edward C. Wells Professor of Aeronautics and Astronautics, Stanford University, and **Per K. Enge**, Department of Aeronautics and Astronautics, Stanford University, were members of the workshop steering committee. Paper, \$65.00.

Macondo Well-Deepwater Horizon Blowout: Lessons for Offshore Drilling Safety.

The blowout of the Macondo well on April 20, 2010, caused the deaths of 11 workers on the Deepwater Horizon drilling rig and seriously injured 16 others. There were also serious consequences for the companies involved in the drilling operations, the Gulf of Mexico ecosystems, and the economy of the region and beyond. During the three months it took to kill the well, nearly five million barrels of oil spilled into the gulf. The purpose of this report is to look into the causes of the blowout and provide recommendations for the oil and gas industry and government regulators for decreasing the likelihood and impact of future losses of well control during offshore drilling.

The study committee for this joint report by NAE and the National Research Council, recommends that companies involved in offshore drilling adopt a “system safety” approach to anticipating and managing potential danger at every level of operation—from ensuring the integrity of wells to designing blowout preventers that can function under all foreseeable conditions. In addition, regulatory

oversight should combine strong industry safety goals with mandatory oversight at critical points in drilling operations.

The committee also discusses the ultimate responsibility and accountability for well integrity and the safety of offshore equipment, formal system safety education and training for personnel engaged in offshore drilling, and guidelines to ensure that well designs incorporate protection against credible risks associated with the drilling and abandonment processes.

NAE members on the study committee were **Donald C. Winter** (chair), Former Secretary of the Navy, U.S. Department of the Navy; **David E. Daniel**, president, The University of Texas at Dallas; **Roger L. McCarthy**, consultant, McCarthy Engineering; **Keith K. Millheim**, president, Strategic Worldwide LLC; **M. Elisabeth Paté-Cornell**, Burt and Deedee McMurtry Professor Management Science and Engineering, Stanford University; **Robert F. Sawyer**, Class of 1935 Professor of Energy Emeritus, Department of Mechanical Engineering, University of California, Berkeley; **Arnold F. Stancell**, retired vice president, Mobil Oil,

and Turner Professor of Chemical Engineering Emeritus, Georgia Institute of Technology; and **Mark D. Zoback**, Benjamin M. Page Professor of Geophysics, Stanford University. Paper, \$49.00.

Good Guys, Wiseguys and Putting up Buildings: A Life in Construction.

Sam Florman, Chairman of Kreisler Borg Florman General Construction Company, has just published his seventh book, a charming, adventurous memoir that begins with his experiences as a Navy Seabee during WWII and follows his career in the construction of New York public housing, hospitals, schools, and places of worship. In his new book, “Florman emphasizes (and embodies) the interaction between technology and the social fabric of the nation, and his descriptions of the politicians, technocrats, do-gooders, and Mafiosi with whom he came in contact will change the reader’s view of the construction industry.” *Fortune Magazine* says “Florman is the man we’ve been looking for. Incredible as the combination may appear, he is both a practicing engineer and a truly gifted writer.” St. Martin’s Press, \$25.99.

Calendar of Events

June 11–12	NAE Workshop on Making Value: Integrating Manufacturing, Design, and Innovation to Thrive in the Changing Global Economy Venable Conference Center, Washington, D.C.	August 1–August 2	NAE Council Meeting Woods Hole, Massachusetts	September 19–20	National Engineering Forum New York, New York
July 11–12	Integrated STEM Committee Meeting	August 30–31	CAETS Meeting Zurich, Switzerland	September 28–29	NAE Council Meeting
		September 13–15	U.S. Frontiers of Engineering Symposium Warren, Michigan	September 29	NAE Peer Committee Meetings
				September 30–October 1	NAE Annual Meeting

In Memoriam

FRANKLIN H. BLECHER, 82, retired executive director, Integrated Circuit Design Division, AT&T Bell Laboratories, died on January 12, 2012. Dr. Blecher was elected to NAE in 1979 “for contributions to the development of solid-state circuits and leadership in the development of large telecommunication systems.”

BERNARD L. COHEN, 87, Professor Emeritus of Physics and Astronomy and Environmental and Occupational Health, University of Pennsylvania, died on March 17, 2012. Dr. Cohen was elected to NAE in 2003 “for fundamental contributions to our understanding of low-level radiation.”

DALE R. CORSON, 97, President Emeritus, Cornell University, died on March 31, 2012. Dr. Corson was elected to NAE in 1981 for “leadership in evaluation of engineering enterprises vital to the national welfare, contributor to vital military electronic developments, and leadership in engineering education.”

ALAN COTTRELL, 92, research fellow, Department of Materials Sci-

ence and Metallurgy, University of Cambridge, died on February 15, 2012. Sir Cottrell was elected a foreign associate of NAE in 1976 “for contributions to science and technology of materials in engineering structures and applications of engineering science to major societal problems.”

THOMAS M. COVER, 73, Kwoh-Ting Li Professor of Engineering and professor of electrical engineering and statistics, Stanford University, died on March 26, 2012. Dr. Cover was elected to NAE in 1995 “for contributions to the theory and practice of pattern recognition, information theory, and communications.”

RUTH M. DAVIS, 83, president and CEO, Pymatuning Group, Inc., died on March 28, 2012. Dr. Davis was elected to NAE in 1976 “for contributions to computer science, particularly information science technology.”

KENNETH McK. ELDRED, 82, president, Ken Eldred Engineering, died on January 30, 2012. Mr. Eldred was elected to NAE in

1975 “for contributions in noise and vibration control of air, space, and transportation vehicles and in delineating acceptable noise environment for people.”

RICHARD G. FARMER, 83, research professor, Department of Electrical Engineering, Arizona State University, died on March 26, 2012. Mr. Farmer was elected to NAE in 2006 “for the solution of problems in the dynamic operation of electric power systems, including subsynchronous resonance and system stabilization.”

HAROLD K. FORSEN, 79, retired senior vice president, Bechtel Corporation, died on March 7, 2012. Dr. Forsen was elected to NAE in 1989 “for outstanding technical and leadership contributions to fission, fusion, and energy technology in industry and academia.”

ELMER L. GADEN, 88, Wills Johnson Professor Emeritus, Department of Chemical Engineering, University of Virginia at Charlottesville, died on March 10, 2012. Dr. Gaden was elected to NAE in 1974 “for contributions to fermentation

technology and leadership in the field of bioengineering.”

DONALD G. ISELIN, 89, U.S. Navy, retired, died on March 10, 2012. Rear Adm. Iselin was elected to NAE in 1980 “for innovative leadership in planning and meeting civil engineering challenges of great importance to the nation.”

CLYDE E. KESLER, 89, Professor Emeritus of Civil Engineering, and of Theoretical and Applied Mechanics, University of Illinois, died on December 30, 2011. Mr. Kesler was elected to NAE in 1977 “for contributions to the understanding of fatigue, fracture, creep, shrinkage, and relaxation of concrete.”

SIDNEY METZGER, 94, retired vice president and chief scientist, COMSAT Corporation, died on December 22, 2011. Mr. Metzger was elected to NAE in 1976 “for development of early radio relay systems and communication satellite systems.”

HAROLD S. MICKLEY, 93, retired vice chairman, Stauffer Chemical Company, died on December 3, 2011. Dr. Mickley was elected to NAE in 1978 “for research on transpired turbulent

boundary layers, and leadership in the industrial development of oxy-hydrochlorination processes.”

YASUO MORI, 89, Professor Emeritus, Tokyo Institute of Technology, died on March 20, 2012. Dr. Mori was elected a foreign associate of NAE in 1986 “for contributions to heat transfer and energy conversion research, and for contributions to international scholarly exchanges.”

THOMAS J. MURRIN, 82, Westinghouse Electric, retired, died on January 30, 2012. Mr. Murrin was elected to NAE in 1984 “for his innovative and far-sighted contributions to both industry and government in the fields of productivity and quality improvement.”

PAUL E. QUENEAU, 101, Professor Emeritus, Thayer School of Engineering, Dartmouth College, died on March 31, 2012. Dr. Queneau was elected to NAE in 1981 “for innovative leadership in the invention and commercial development of efficient technology for extraction of nickel, copper, and cobalt.”

IVAN M. VIEST, 89, president, IMV Consulting, died on February 11, 2012. Dr. Viest was elected

to NAE in 1978 “for contributions to design of structures, including composite construction, earthquake resistance, and load factor design specifications.”

DAVID C. WHITE, 89, Ford Professor of Engineering, Emeritus, Massachusetts Institute of Technology, died on January 11, 2012. Dr. White was elected to NAE in 1975 “for contributions as an engineering educator and leader in energy conversion technology, energy systems analysis, and energy planning.”

ROBERT V. WHITMAN, 84, Professor Emeritus of Civil Engineering, Massachusetts Institute of Technology, died on February 25, 2012. Dr. Whitman was elected to NAE in 1975 “for pioneering research in soil dynamics, especially in predicting and controlling earthquake effects on constructed facilities.”

HOLDEN W. WITHINGTON, 94, retired vice president, engineering, Boeing Commercial Airplane Company, died on December 9, 2011. Mr. Withington was elected to NAE in 1980 “for contributions to the advancement of both military and commercial airplane designs.”

Publications of Interest

The following reports have been published recently by the National Academy of Engineering or the National Research Council. Unless otherwise noted, all publications are for sale (prepaid) from the National Academies Press (NAP), 500 Fifth Street, N.W., Lockbox 285, Washington, DC 20055. For more information or to place an order, contact NAP online at <http://www.nap.edu> or by phone at (888) 624-8373. (Note: Prices quoted are subject to change without notice. Online orders receive a 20 percent discount. Please add \$4.50 for shipping and handling for the first book and \$0.95 for each additional book. Add applicable sales tax or GST if you live in CA, CT, DC, FL, MD, NC, NY, VA, WI, or Canada.)

Industrial Methods for the Effective Testing and Development of Defense Systems. In the last 15 years, the National Research Council Committee on National Statistics has published a number of studies, sponsored by the U.S. Department of Defense, on using statistical methods to improve the testing and development of defense systems. The current report identifies engineering practices, such as operational testing, modeling and simulation, and so on, that have been used by industry for system development and testing and are likely to be useful in the defense environment. The report includes discussions of both large issues and three specific topics: (1) finding failure modes earlier, (2) technology maturity, and (3) using all relevant information for operational assessments.

NAE members on the study committee were **W. Peter Cherry**, independent consultant, Ann Arbor, Michigan, and **Elaine Weyuker**, AT&T Fellow, AT&T Labs Research. Paper, \$35.00.

Predicting Outcomes from Investments in Maintenance and Repair for Federal Facilities. The deteriorating condition of federal facilities poses economic, safety, operational, and environmental risks, interferes with federal agencies fulfilling their missions, and complicates the achievement of public policy goals. Primary factors underlying this deterioration are the age of federal facilities—about half are at least 50 years old—and decades of inadequate investment in maintenance and repair (M&R). Although these issues are not new and there are no quick fixes, the current operating environment provides an impetus and an opportunity for improvement. The report committee identifies processes and practices for putting the current portfolio of federal facilities on a sustainable economic, physical, and environmental course. These processes include new ways of predicting or quantifying expected outcomes from a given level of M&R investment in the facilities themselves or in facilities' systems. The committee also describes strategies, measures, and data for determining actual outcomes.

NAE member **Alfredo H-S. Ang**, research professor of civil engineering, University of California, Irvine, was a member of the study committee. Paper, \$40.00.

Improving Measures of Science, Technology, and Innovation: Interim Report.

The National Center for Science and Engineering Statistics (NCSES) at the National Science Foundation is one of 14 major statistical agencies in the federal government, at least five of which collect information on science, technology, and innovation (STI) in the United States and abroad. In the America COMPETES Reauthorization Act of 2010, NCSES's mandate was expanded and codified to include the collection, acquisition, analysis, as well as reporting and dissemination of data on trends in research and development (R&D), U.S. competitiveness in science, technology, and R&D, and the status and progress of U.S. science, technology, engineering, and mathematics (STEM) education. The authoring panel undertook a comprehensive review of STI indicators in Japan, China, India, and several countries in Europe, Latin America, and Africa. Based on this review and a review of NCSES' indicators, the panel recommends near-term action on two levels: (1) the development of new policy-relevant indicators based on NCSES survey data or on data collections at other statistical agencies; and (2) the exploration of new data extraction and management tools for generating statistics using automated methods of harvesting unstructured or scientific data and data derived from administrative records.

NAE member **Katharine G. Frase**, vice president, Industries Research, International Business

Machines Corporation, was a member of the study panel. Paper, \$31.00.

Prepositioning Antibiotics for Anthrax.

If terrorists released *Bacillus anthracis* over a large city, hundreds of thousands of people could be at risk of contracting the disease. Although plans for the rapid delivery of medical countermeasures (antibiotics) to a large number of people have been improved over the last decade, many public health authorities and policy experts fear that they could not respond quickly enough in the event of a very large-scale anthrax attack. The U.S. Department of Health and Human Services Office of the Assistant Secretary for Preparedness and Response commissioned the Institute of Medicine (IOM) to look into the advantages and disadvantages of prepositioning antibiotics, which would require storing them close to, or even distributing them to people who would need rapid access to them. The IOM study committee defined and evaluated three prepositioning strategies that would complement existing, centralized stockpiling strategies, such as the Strategic National Stockpile maintained by the Centers for Disease Control and Prevention.

NAE members **Stephen M. Pollock**, Herrick Emeritus Professor of Manufacturing, University of Michigan, and **Louis Anthony (Tony) Cox Jr.**, president, Cox Associates LLC, were members of the study committee. Paper, \$64.00.

Strategies and Priorities for Information Technology at the Centers for Medicare and Medicaid Services.

The Centers for Medicare and Medicaid Services (CMS) is the agency responsible for providing health coverage to

seniors and people with disabilities, individuals and families with limited incomes, and children (almost 100 million beneficiaries in all). The agency's core mission, which was established about 40 years ago, was to ensure prompt payment of claims, which today total more than 1.2 billion annually. To meet these demands, CMS must update and greatly improve its information technology (IT) systems. This report provides a review of CMS' plans to expand its IT capabilities and recommends how the agency's business processes, practices, and information systems can be developed to meet growing demands. The recommendations and conclusions fit into four categories: (1) the need for a comprehensive strategic technology plan; (2) the need for a metamethodology to guide an iterative, incremental, phased transition of business and information systems; (3) the critical need for high-level strategic IT planning and adaptations in CMS's internal organization and culture; and (4) the importance of data and analyses to stakeholders inside and outside CMS.

NAE member **Laura M. Haas**, IBM Fellow and director of computer science, IBM Almaden Research Center, was a member of the study committee. Paper, \$45.00.

The National Weather Service Modernization and Associated Restructuring: A Retrospective Assessment.

The Modernization and Associated Restructuring (MAR) of the National Weather Service (NWS), a complex re-engineering project, lasted a decade, cost an estimated \$4.5 billion, and required revolutionary, often difficult, changes, such as the development of a framework for keeping up with technological

changes, the procurement of large, complex technical systems, and decisions that affected the careers and personal lives of a large portion of the NWS workforce. This report provides the first comprehensive assessment of the execution of the MAR and its impact on weather services in the United States. The review committee also identifies lessons learned to support future improvements in NWS capabilities.

NAE member **John A. Armstrong**, retired vice president for science and technology, International Business Machines Corp., chaired the study committee. Paper, \$42.00.

Information Sharing and Collaboration: Applications to Integrated Biosurveillance: Workshop Summary.

After the September 11, 2001, terrorist attacks and subsequent anthrax mailings, the U.S. government prioritized a biosurveillance strategy for detecting, monitoring, and characterizing health threats to human and animal populations, food, water, agriculture, and the environment. However, some challenges to implementing this coordinated strategy must still be addressed. On September 8–9, 2011, the Institute of Medicine held a workshop to explore information-sharing and collaboration to overcome these challenges. This volume provides a summary of the workshop presentations and discussions.

NAE member **Richard C. Larson**, Mitsui Professor, Massachusetts Institute of Technology, was a member of the study committee. Paper, \$37.00.

An Assessment of the Deep Underground Science and Engineering Laboratory.

Deep underground science and engineering laboratories (DUSELs)

may open the way to our understanding of the physics of the grand unification of natural forces. Built to shield extremely sensitive detectors from surrounding noise and signals associated with cosmic rays, DUSELs have been established in the last 30 years at a number of sites worldwide. To date, the United States has built primarily small underground laboratories, but the science community has advocated for larger facilities on the scale of laboratories in other countries. This report provides evaluations of the major questions and experiments in physics that could be explored and the potential impact of a DUSEL on education and public outreach. The study committee also discusses the importance of developing U.S. programs similar to science programs in other parts of the world.

NAE member **Charles Fairhurst**, senior consulting engineer, Itasca Consulting Group Inc., and Professor Emeritus, University of Minnesota, was a member of the study committee. Paper, \$42.00.

Progress, Challenges, and Opportunities for Converting U.S. and Russian Research Reactors: A Workshop.

Highly enriched uranium (HEU) is used for two major civilian purposes: as fuel for research reactors and as targets for medical isotope production. However, because HEU can also potentially be used to build nuclear explosive devices, ensuring that these materials are protected is essential to their continued use for civilian purposes. The National Research Council (NRC) of the National Academies and the Russian Academy of Sciences (RAS) held a joint symposium on June 8–10, 2011, to address these issues. This summary covers

(1) recent progress on converting research reactors to protect HEU, with a focus on reactors of United States and Russian Federation origin; (2) overcoming challenges to the conversion of reactors, using research reactors more effectively, and enabling new reactor missions; (3) plans, challenges, and opportunities for converting research reactors; and (4) actions by U.S. and Russian organizations that would promote conversion. This volume also includes the agenda for the symposium, biographical sketches of committee members, and the statement of task.

NAE member **Richard A. Meserve**, president, Carnegie Institution for Science, chaired the workshop steering committee. Paper, \$43.00.

Interim Report—Status of the Study “An Assessment of the Prospects for Inertial Fusion Energy.”

Despite substantial scientific and technological progress in inertial confinement fusion, many technologies necessary for an integrated inertial fusion energy system are still at an early stage of development. In addition, critical scientific and engineering challenges remain for all approaches to inertial fusion energy. In this interim report, the Committee on the Prospects for Inertial Confinement Fusion Energy Systems outlines its preliminary conclusions about the feasibility of inertial fusion energy and its recommendations for moving ahead. The committee also describes its next steps in preparation for the final report.

NAE members on the study committee were **Gerald L. Kulcinski** (co-chair), associate dean for research, Grainger Professor of Nuclear Engineering, and director,

Fusion Technology Institute, University of Wisconsin, Madison; **Robert L. Byer**, William R. Kenan Jr. Professor of the School of Humanities and Sciences, and co-director, Stanford Photonics Research Center, Stanford University; **Richard L. Garwin**, IBM Fellow Emeritus, IBM Thomas J. Watson Research Center; and **Lawrence T. Papay**, CEO and principal, PQR LLC, and retired sector vice president for integrated solutions, Science Applications International Corporation. Paper, \$35.00.

A Framework for K–12 Science Education: Practices, Crosscutting Concepts, and Core Ideas.

To address the critical issues of U.S. competitiveness and educate students in science and engineering as preparation for entering the workforce, this report puts forward a proposal for K–12 science education that would both capture students’ interest and provide them with foundational scientific knowledge. The report committee outlines expectations for students in grades K–12 to inform the development of new standards for science education and, subsequently, revisions to curricula, instruction, assessments, and professional development for educators. The three core ideas and practices for K–12 science and engineering education are crosscutting concepts with applications in both science and engineering; scientific and engineering practices; and disciplinary core ideas in the physical sciences, life sciences, and earth and space sciences and for engineering, technology, and applications of science. The overarching goal is for all high school graduates to have sufficient knowledge to engage in public discussions of science-related issues, be knowledgeable consumers of

scientific and technical information, and be able to pursue the careers of their choice. This report is the first step toward informing state-level decisions and developing a research-grounded basis for improving science instruction.

NAE member **Linda P.B. Katehi**, chancellor, University of California, Davis, was a member of the study committee. Paper, \$39.95.

Health IT and Patient Safety: Building Safer Systems for Better Care.

In *To Err is Human*, a landmark study by the Institute of Medicine published in 1999, it was estimated that 44,000 to 98,000 lives are lost every year as a result of medical errors. In that study, the use of IT was suggested as a way to improve the safety and effectiveness of care (e.g., computerized prescriptions). Since then, the federal government has invested billions of dollars in the development and use of health IT. However, unless these systems are designed and used appropriately, they can add a layer of complexity to the already complex delivery of health care, which could lead to unsafe conditions, serious injuries, and even death. Safe implementation of health IT requires shared responsibility by vendors and health care organizations. The authoring committee of this report provides recommendations for developing a framework for patient safety and health IT focused on mitigating the risks of health IT-assisted care and identifies other areas of concern. The committee also identifies comprehensive and specific options and opportunities for public and private intervention to make health care safer.

NAE members on the study committee were **James P. Bagian**, director, Center for Health Engineering

and Patient Safety, and chief patient safety and systems innovation officer, Department of Industrial and Operations Engineering, University of Michigan, and **Michael Lesk**, professor, Rutgers University. Paper, \$36.00.

Technical Evaluation of the NASA Model for Cancer Risk to Astronauts Due to Space Radiation.

Astronauts on missions to the International Space Station or missions that involve extended stays on the lunar surface, a near-Earth object, or Mars, must be protected from radiation risks from solar particle events, galactic cosmic rays, secondary radiation from surface impacts, and even nuclear-isotope power sources transported with them. Early and late radiation health effects from such exposures range from early signs of radiation sickness to cancer, damage to the central nervous system, cataracts, cardiovascular damage, heritable effects, impaired wound healing, and infertility. As a result of recent research, much of it sponsored by NASA, many aspects of space radiation environments are relatively well characterized, but there are still uncertainties about biological effects. The present report includes an evaluation of NASA's proposed space radiation cancer risk assessment model (described in the 2011 NASA report, *Space Radiation Cancer Risk Projections and Uncertainties—2010*), including model components, input data for radiation types, estimated doses, epidemiology, and associated uncertainties. The authoring committee also identifies gaps in NASA's research strategy for reducing uncertainties in the risks of cancer.

NAE member **B. John Garrick**, independent consultant, Laguna

Beach, California, was a member of the study committee. Paper, \$36.00.

The Comprehensive Nuclear Test Ban Treaty: Technical Issues for the United States.

This review and update of the 2002 National Research Council report *Technical Issues Related to the Comprehensive Nuclear Test Ban Treaty (CTBT)*, includes an assessment of plans to maintain the safety and reliability of the U.S. nuclear stockpile (without test explosions); U.S. capability of detecting, locating, and identifying nuclear explosions; commitments necessary to sustain the stockpile and U.S. and international monitoring systems; and potential technical advances by other countries achieved through evasive or unconstrained testing. The authoring committee of the present report concludes that sustaining our technical capabilities will require that the National Nuclear Security Administration, with the support of others, develop a strong scientific and engineering base maintained through continuing experiments in conjunction with ongoing analysis, a vigorous surveillance program, and an adequate ratio of performance margins to uncertainties. This report also emphasizes the need for modernized production facilities and a competent and capable workforce with expertise in nuclear security.

NAE member **Richard L. Garwin**, IBM Fellow Emeritus, IBM Thomas J. Watson Research Center, was a member of the study committee. Paper, \$45.00.

Application of Lightweighting Technology to Military Vehicles, Vessels, and Aircraft.

"Lightweighting," reducing the weight of all kinds of structures—from laptops to bicycles to

automobiles to airplanes to buildings—is a concept well known to structural designers and engineers. The advantages of lighter weight structures include higher energy efficiency, better designs, improved usability, and better coupling with new, multifunctional features. Lightweighting for military vehicles is especially challenging because of the stringent requirements for survivability, maneuverability, and transportability. This new report assesses the current state of lightweighting for land, sea, and air vehicles and recommends improvements in both lightweight materials and lightweight design; the availability of suitable materials from domestic manufacturers; and the performance of lightweight materials and manufacturing technologies. The assessment also includes the “trade space,” that is, the effect of using lightweight materials or technologies on the performance and function of vehicle systems and components and manufacturing capabilities and affordable manu-

facturing technologies to facilitate lightweighting.

NAE members on the study committee were **John E. Allison**, professor, Department of Materials Science and Engineering, University of Michigan; **David R. Clarke**, professor of materials, School of Engineering and Applied Sciences, Harvard University; and **Wesley L. Harris**, Charles Stark Draper Professor of Aeronautics and Astronautics and associate provost, Massachusetts Institute of Technology. Paper, \$39.75.

Effective Tracking of Building Energy Use: Improving the Commercial Buildings and Residential Energy Consumption Surveys.

The United States uses nearly one-fifth of the world’s energy, and that number is expected to increase by 0.7 percent a year as a result of population growth and associated growth in housing, commercial floor space, transportation, goods, and services. Energy used by the commercial and residential sectors, which represents

approximately 40 percent of total U.S. energy consumption, is also expected to increase. The Commercial Buildings Energy Consumption Survey (CBECS) and Residential Energy Consumption Survey (RECS), major studies conducted by the Energy Information Administration, are the most relevant sources of data on energy consumption in these sectors. However, many design decisions and operational procedures for the CBECS and RECS, which were developed in the 1970s and 1980s, have not been updated because of resource limitations. This report provides (1) recommendations for redesigning both surveys based on a review of the changing needs of data users and (2) an assessment of relevant developments in survey methods.

NAE member **Maxine Savitz**, retired general manager, Technology/Partnerships, Honeywell Inc., was a member of the study committee. Paper, \$34.50.

Did you know...

Making a legacy gift to NAE is easy, will benefit the nation for generations to come...and won't affect your lifestyle.



Legacy gifts have a lasting impact on NAE's financial stability and support our ability to continue providing timely, objective, science-based advice on issues important to our country and the world.

Bequests in your will are simple, frequently used vehicles for arranging legacy gifts.

Your bequest may be in a dollar amount, a percentage of the estate, or an exact asset to be devised and can be designated for an unrestricted or a specific use.

Retirement funds (IRAs and 401Ks) provide a tax-wise way to make a charitable gift. Income taxes have not been applied to these assets, so if your heirs are named as beneficiaries, they must pay those taxes. When a charity is named as a beneficiary, however, it receives the designated amount with no tax consequences. Simply call your plan administrator for a beneficiary form.

Insurance policies are sometimes forgotten assets that may no longer be needed to support your family. You can name NAE as the beneficiary of a policy, or you can transfer ownership of a fully-paid policy to NAE and receive a charitable tax deduction.

All members and friends who have made a provision to support NAE with a gift that will be realized in the future are invited to become members of the **Heritage Society**. If you have made a planned gift to benefit NAE, please let us know so we can thank you and welcome you as a member of this prestigious society.

We suggest you consult with your attorney or financial advisor on all estate planning matters. For more information, contact **Clare Flanagan**, Director of Gift Planning, at 202.334.1546 or cflanagan@nae.edu.

The BRIDGE

(USPS 551-240)

National Academy of Engineering
2101 Constitution Avenue, N.W.
Washington, DC 20418

Periodicals
Postage
Paid

THE NATIONAL ACADEMIES™

Advisers to the Nation on Science, Engineering, and Medicine

The nation turns to the National Academies—National Academy of Sciences, National Academy of Engineering, Institute of Medicine, and National Research Council—for independent, objective advice on issues that affect people's lives worldwide.

www.national-academies.org