



A review of examples and opportunities to quantify the grid reliability and resilience impacts of energy efficiency

Juan Pablo Carvallo^{*}, Natalie Mims Frick, Lisa Schwartz

Ernest Orlando Lawrence Berkeley National Laboratory, 1 Cyclotron Road, MS 90R4000, Berkeley, CA, 94720-8136, USA

ARTICLE INFO

Keywords:

Energy efficiency
Reliability
Resilience
Regulation
Planning

ABSTRACT

Grid reliability and resilience are foundational to meeting electricity needs and have significant economic and societal impacts. Energy efficiency can help meet grid reliability objectives and improve resilience, but metrics and methods used today may not fully recognize these benefits. This paper explains how existing planning processes for bulk power and distribution systems capture the impact of energy efficiency on power system reliability and resilience, with illustrative examples. We identify limitations in using existing reliability and resilience metrics to quantify efficiency and other distributed energy resource (DER) benefits. The paper concludes with opportunities for regulators and utilities to enhance planning practices to better capture the reliability and resilience value of energy efficiency and identifies research needs.

1. Introduction

Utilities and regional grid operators conduct various types of power system planning to identify how portfolios of resources to meet future electricity needs and policy and regulatory requirements would perform (Fig. 1). Bulk power system (BPS) planning is typically performed by utilities and grid operators to determine the least-cost mix of generation and transmission resources to serve projected load levels, subject to various scenarios and stressors. Distribution system planning ensures that electricity delivery to customers occurs within prescribed levels of quality of product (e.g. voltage levels) and service (e.g. reliability and restoration times). Demand side management planning identifies the value that energy efficiency, demand response, and other demand side interventions create to the customer and/or distribution system. It is important to note that these processes are generally performed in isolation from each other.

Best planning practices for the BPS and distribution system consider cost, risk, and uncertainty and include both supply- and demand-side resources—energy efficiency and other DERs, including demand response, distributed generation and storage, microgrids and managed electric vehicle charging. Energy efficiency, from traditional measures to more time- and location-sensitive approaches, provides important grid reliability and resilience benefits, on its own or integrated with other DERs (Table 1).

This paper discusses how reliability and resilience benefits of

efficiency are currently considered and valued in electricity system planning, identifies policy challenges, offers regulatory opportunities for improvement, and describes research needs. It builds on existing research on the magnitude and cost of energy efficiency programs funded by utility customers and projections of future energy savings for utility systems. It also expands on recent reports documenting examples of utilities treating energy efficiency on a comparable basis to generating resources in bulk power system planning, and using energy efficiency and other DERs as non-wires alternatives (NWA) to meet distribution system needs (Frick et al. 2020a, 2021). However, energy efficiency programs are typically not designed to capture and deliver reliability and resilience benefits, nor are these benefits typically reflected in electricity system planning. The paper uses case studies to extract best practices in quantifying reliability and resilience benefits of energy efficiency. Examples in this brief focus on energy efficiency, but include other demand-side resources such as conservation and demand response. A critical analysis of these best practices informs our findings for technical and regulatory challenges and supports our ideas for opportunities for improvement and further research needs.

This work contributes to the literature on non-energy benefits (NEBs) of energy efficiency, which has sought to research methods and challenges to identify, quantify, and internalize NEBs into benefit cost analysis (Tonn and Peretz, 2007). This effort stems from the recognition that existing methods and assumptions do not fully capture the full value of efficiency resources (Woolf et al., 2012b). In the U.S., about 27 states

^{*} Corresponding author.

E-mail address: jpcarvallo@lbl.gov (J.P. Carvallo).

require the consideration of NEB in screening processes (Caputo et al., 2017). Screening guidelines for regulators recommend including several avoided costs, included generation, transmission, and distribution capacity and energy, as well as environmental compliance, reduced line losses and price suppression effects, but there is little to no analysis of reliability and resilience benefits (Woolf et al., 2012a). Research has explored how to account for NEB on housing (Amann, 2006; Norton et al., 2016), performance contracting (Larsen et al., 2012), and industry (Cagno et al., 2019; Nehler and Rasmussen, 2016; Pye and McKane, 2000). However, current accounting and monetizing of NEBs is still insufficient to capture the full array of benefits from energy efficiency. In the context of reliability and resilience benefits, recent work has reviewed existing state efficiency screening practices and validated the dearth of focus on reliability and resilience (Relf and Jarrah, 2020). However, this work does not explain the mechanisms to quantify reliability and resilience benefits of efficiency and does not provide regulatory and policy guidelines to improve their quantification. This paper follows the concepts in Mills and Rosenfeld (1996) to focus on benefits from the consumer’s perspective. This work also contributes to the emergent literature on policy implementations to assess, maintain, and enhance the resilience of a system (Gatto and Drago, 2020; Silverstein et al., 2018). There is evidence that efficiency enhances the resilience of economies that invest in sustainable technologies (Aldieri et al., 2021). This paper diagnoses the mechanisms through which efficiency enhances reliability and resilience, and proposes guidelines for regulators to improve the measurement of these benefits.

The overall methodological framework for this paper is shown in Fig. 2 and consists in three stages. A first stage involves review and best practices in energy efficiency application for reliability in BPS planning based on prior work by the authors (Frick et al., 2020a; Carvallo et al., 2021a). The outcome of this stage are mechanisms to value the reliability contribution of efficiency. A second stage involves comprehensive review of existing NWA and demand side management benefit-cost analysis (BCA) to identify (1) quantification of efficiency co-benefits and (2) reliability impacts of other DER based on the mechanisms identified in the first stage. Gaps analysis (Channon and Sammut-Bonnici, 2015) is used with (1) to identify what aspects of NWA and BCA are insufficient to produce the types of efficiency reliability impacts available in BPS planning. This is complemented with an analogy analysis (Bartha, 2022) used with (2) to track how the reliability benefits of other DER may apply to efficiency with adequate metrics and methods. Both outcomes are then combined to identify challenges and opportunities to quantify reliability and resilience benefits of energy efficiency. The third stage involves validation of recommendations with experts to ensure regulatory relevance and technical feasibility. The framework is based on

Table 1
Examples of energy efficiency reliability and resilience benefits.

	Power system planning processes		
	Bulk power system	Distribution system	Demand-side management
Reliability	Energy efficiency contributes to meeting reliability needs at least cost and risk. In wholesale capacity markets, energy efficiency lowers capacity auction prices.	In some cases, distribution capacity expansion needs for reliability can be deferred, mitigated, or avoided by using DERs, including efficiency, as non-wires alternatives.	Efficient equipment extends the duration of storage backup during interruptions.
Resilience	System operator calls for emergency conservation ^a can prevent large-scale blackouts.	Lower loads reduce equipment overloading and thermal wear and tear, reducing the likelihood of equipment failure.	Efficient buildings maintain habitable indoor conditions for longer periods of time during power interruptions.

^a Conservation is conceptually different from energy efficiency because it requires consumers to use less energy for a lesser service, whereas efficiency provides the same (or higher) level of service with less energy.

grounded theory (Charmaz, 1996), an inductive method developed to extract hypotheses from data analysis, rather than using data to test hypotheses. In this paper, the analysis of planning processes produces information that is used to formulate challenges and opportunities that can be then tested in regulatory settings. Our findings are based on comprehensive reviews of state-level planning practices, which makes the technical and regulatory recommendations applicable throughout the U.S. The relatively homogenous regulatory approach for distribution system and demand side management planning makes our results applicable to a wide set of jurisdictions and countries.

This paper focuses on three planning processes because these processes are designed to identify cost-effective and/or value-maximizing resources to add to each system. It follows that shortcomings on how the reliability and resilience value is captured for certain resources will affect the optimal mix chosen for system expansion. This paper’s main contribution is then the identification of how existing planning processes are falling short of capturing the reliability and resilience value of efficiency, and offer technical and regulatory suggestions for improvement.

This paper does not explore in detail reliability and resilience benefits of DERs other than efficiency, such as demand response, battery

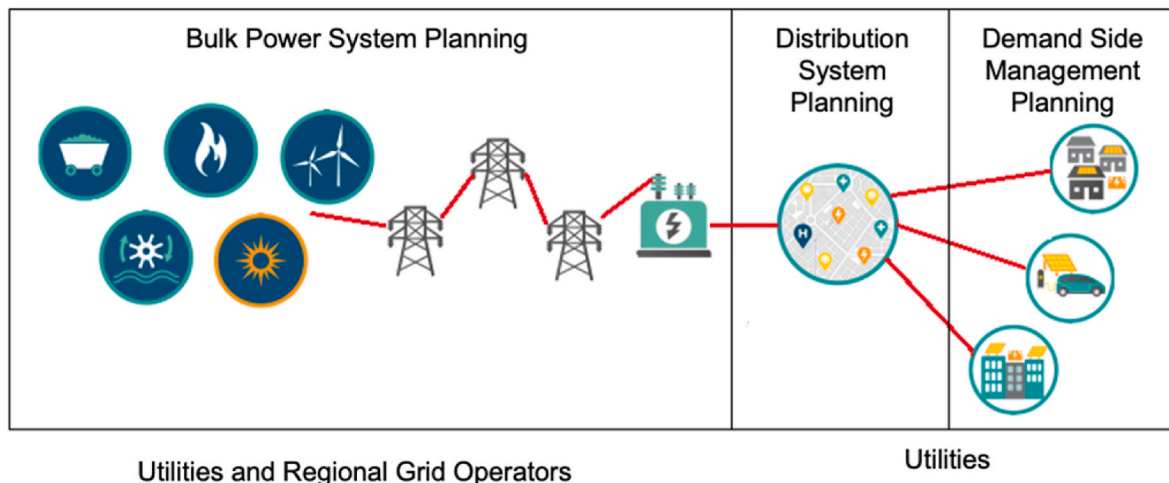

Fig. 1. Power system planning processes.

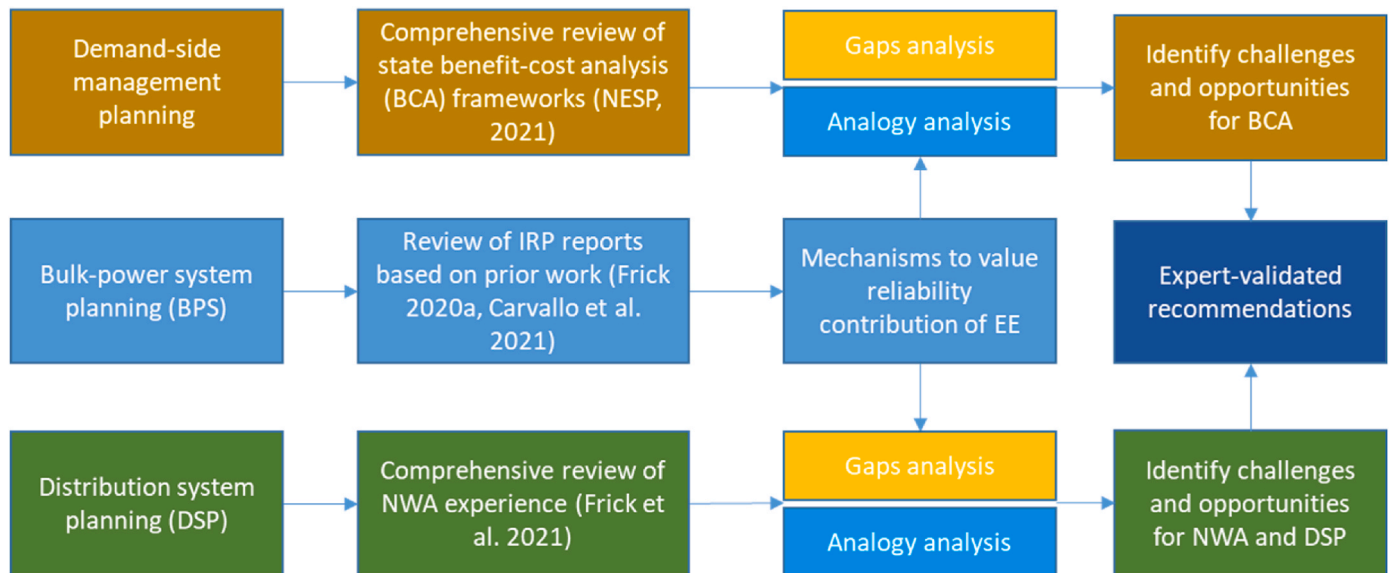

Fig. 2. Methodological framework developed for this paper.

storage, microgrids, and managed charging of electric vehicles. For additional information on the reliability and resilience benefits of these DERs (Rickerson et al. 2019, 2022). In addition, this paper does not discuss utility distribution system efficiency measures—conservation voltage reduction or volt-VAR optimization.

This paper is organized as follows. The next section provides definitions of reliability and resilience as utilized in this work. The following three sections examine best practices to quantify energy efficiency benefits for reliability and resilience in (1) bulk power system, (2) distribution, and (3) demand-side management planning processes. The paper concludes by identifying technical and policy challenges, opportunities, and research needs. The examples and best practices in this paper draw from the U.S., but these planning practices are common around the world and our findings will be relevant for regulators, policy makers, and utilities in other regions and jurisdictions.

2. Definitions and metrics

This brief focuses on reliability and resilience, and metrics used to measure these attributes, in the context of electricity system *planning*. Energy efficiency also offers important benefits for *operation* timeframes. We include a brief discussion on the use of conservation for reliability and resilience in operation timeframes in the section, “Evaluation of efficiency’s reliability benefits in long-term BPS planning”. The working definitions of reliability and resilience that frame our discussion are as follows.

2.1. Reliability

A recent U.S. Department of Energy report defines electric reliability as “the ability to maintain the delivery of electric power to customers in the face of routine uncertainty in operating conditions” (Eto et al., 2020). Different methods are used to measure and assess reliability in BPS and distribution systems.

Reliability metrics for the BPS focus on the operational (current or near-term conditions) and planning (longer term) time horizons as defined by the North American Electric Reliability Corporation (NERC):

- *Operating reliability* is the ability of the BPS to withstand sudden disturbances, such as electric short circuits or the unanticipated loss of system elements from contingencies, while avoiding uncontrolled cascading blackouts or damage to equipment (NERC, 2020a).

- *Adequacy* is the ability of the electricity system to supply the aggregate electrical demand and energy requirements of the end-use customers at all times, taking into account scheduled and reasonably expected unscheduled outages of system elements.

Reliability metrics for utility distribution systems focus on tracking the interruption of the delivery of electricity in sufficient quantities and of sufficient quality to meet electricity users’ applications of electricity. The focus on delivery is justified since 90% of interruptions occur within distribution systems (Eto, 2016). Typical reliability metrics report the annual duration (e.g., System Average Interruption Duration Index (SAIDI) and Customer Average Interruption Duration Index (CAIDI)) and frequency (e.g., System Average Interruption Frequency Index (SAIFI) and Momentary Average Interruption Frequency Index (MAIFI)) of power interruptions experienced by an average customer (for additional information on reliability metrics, see NERC, 2020b, IEEE, 2012 and EPA, 2018). Losses of power that last 5 min or less are referred to as momentary interruptions, while those lasting more than 5 min are called sustained interruptions.

2.2. Resilience

The definition of resilience continues to evolve as the electricity industry internalizes recent weather events and threat trends, and measures of resilience are a relatively new area of research and development (Petit et al., 2020). Consequently, there are no widely accepted metrics comparable to reliability metrics or standards (Azar et al., 2019; NARUC, 2019; Roeger et al., 2014). For this brief, we define resilience as “the ability to prepare for and adapt to changing conditions and withstand and recover rapidly from disruptions. Resilience includes the ability to withstand and recover from deliberate attacks, accidents, or naturally occurring threats or incidents” (Presidential Policy Directive 21).

Some authors identify resilience as a component of reliability with a focus on preparedness and recovery before and after events that may affect large populations (De Martini et al., 2020; ESIG, 2021). Other authors view resilience as a distinct characteristic of electricity systems. The National Academies of Sciences indicates that “Resilience is not the same thing as reliability. While minimizing the likelihood of large-area, long-duration outages is important, a resilient system is one that acknowledges that such outages can occur, prepares to deal with them, minimizes their impact when they occur, is able to restore service

quickly, and draws lessons from the experience to improve performance in the future.” (National Academies of Sciences, Engineering, and Medicine, 2017, p.10).

Another perspective is that reliability and resilience are a continuum. On one end are common reliability events with local impacts and limited duration. On the other end are “Black Sky Events” with larger, broader impacts occurring less frequently (Azar et al., 2019). The Energy Infrastructure Security Council defines a black sky hazard as “a catastrophic event that severely disrupts the normal functioning of our critical infrastructures in multiple regions, for long durations.” (EIS Council, 2021).

As with the definition of resilience, there are no widely accepted and used metrics for resilience. Conceptually, an effective resilience metric framework would perform probabilistic evaluation of consequences to events and threats (Watson et al., 2014). An applied resilience metric would then measure the probabilistic performance of a system before, during, and after a specific threat, with multiple metrics potentially needed to appropriately assess resilience. Bie et al. (2017) propose simulation, analytical, and empirical methods that can be employed to calculate quantitative resilience metrics. Metrics include restoration costs, time, and probability, or composite metrics that combine the quantity, speed, and time of recovery (Francis and Bekera, 2014). U.S. Department of Energy (DOE) funded research proposed and piloted resilience metrics in four categories: electrical service, critical electrical service, restoration, and monetary (Anderson et al., 2017). Metrics being piloted with industry stakeholders included cumulative energy demand not served, critical customer demand not served, time to recovery, loss of utility revenue, cost of grid damages, and critical services without power, among others. There is no analysis of the impact of energy efficiency on these metrics, and in general little consideration of demand side resources in formulating these metrics.

Regardless of the precise definition of resilience and metrics employed, energy efficiency can provide value during extreme weather events. A recent example is the February 2021 extreme cold weather event in Texas and neighboring states that increased ERCOT’s electricity demand for heating to historic levels. Recent analysis estimates that more than 40% of the state’s electric demand was for heating. In addition, the building stock in Texas was not designed for extreme cold, with little to no insulation and a high reliance on electric resistance heat. The analysis found that if homes had efficient building envelopes and heating systems, ERCOT’s electricity demand could have been reduced by at least 15 GW, which would have dropped the peak enough to offset the loss of most of the generators that failed during the event (Wood et al., 2021).

3. Evaluation of efficiency’s reliability benefits in long-term BPS planning

Long-term BPS planning is a process that estimates least-cost expansion options for the supply- and demand-side mix—considering risk and uncertainty—for a utility or region, based on forecasts and scenarios for loads, fuel costs, technology costs, market prices, and other factors. Vertically integrated utilities conduct long-term BPS planning, focused on resource planning and delivering resources to load centers. Independent system operators and regional transmission organizations conduct planning processes focused on transmission and resource balance. In long-term electric utility planning, reliability is typically treated as a “constraint” when determining the minimum cost system to attain prescribed levels of reliability. This constraint can be expressed in two measures—resource adequacy and operational reliability, defined in the previous section. Ensuring resource adequacy is one of the objectives of long-term planning studies. The results of these studies achieve prescribed levels of adequacy as their main measure of power system reliability.

Resource adequacy targets and performance can be measured in different ways. A common resource adequacy standard is that the

electricity system does not experience a loss of load event more than one day over a 10 year period (NERC, 2020b). The metric used to implement this standard is typically referred to as Loss of Load Expectation (LOLE). A related resource adequacy metric, Loss of Load Probability (LOLP), describes the likelihood that the power system will not be able to meet load in a given hour within a specified period (typically one to five years). Direct implementation of the LOLP or LOLE requires planners to use probabilistic modeling, which can be complex and time consuming. Instead, planning entities typically produce a deterministic resource adequacy metric, referred to as the planning reserve margin, which estimates the additional capacity needed to maintain the appropriate level of resource adequacy for their power system taking load forecast as a given. It is commonly expressed as a percent increase over the system’s expected, weather normalized, peak-hour demand. Because there is no standard planning reserve margin in the United States, the margin varies significantly from utility to utility and between regional grid operators.

In deterministic analysis, energy efficiency contributes to system reliability when it increases the absolute value of the reserve margin at the system peak hour by lowering demand relative to available supply. In probabilistic analysis, energy efficiency reduces the probability of load exceeding generation for specific hours of the year when generation availability is relatively low and load is relatively high, regardless of whether this is the annual peak hour. Fig. 3 shows the probability distribution for loads (in red without energy efficiency and in green with energy efficiency) and generation (in blue). The overlapping area (colored yellow and orange) indicates insufficient resource adequacy, where supply side resources are not enough to meet load and there will be a shortfall. Energy efficiency can shift the load curve to the left, reducing the overlapping area that represents the risk that the system will not have adequate resources from the larger yellow area to the smaller orange area. This translates to a reduction in the LOLP that results in an increase in reliability and resource adequacy.

Following are two examples of how efficiency’s reliability value is considered in long-term BPS planning. The first example identifies reliability benefits from efficiency using a deterministic modeling approach (NERC). The second example uses a probabilistic modeling approach (Northwest Power and Conservation Council). A third example describes operational uses of energy efficiency for reliability outside the planning process.

3.1. NERC annual reliability assessment (deterministic modeling approach)

NERC annually assesses seasonal and long-term reliability of the North American BPS in its Long-Term Reliability Assessment report. As part of the analysis, NERC assesses resource adequacy by calculating the anticipated reserve margin and prospective reserve margin. The anticipated reserve margin is based on existing and planned resources, using planning data with the highest level of certainty. The prospective reserve margin includes all resources in the anticipated reserve margin plus anticipated resources. It then compares these measures to the reference margin level for six regional reliability entities. The reference margin level is usually established by a regulatory authority and is typically based on the load, generation, and transmission characteristics (NERC, 2018). In these assessments, NERC begins with non-coincident demand and subtracts the impacts of energy efficiency and DERs to create the total internal demand forecast (Fig. 4) (NERC, 2018).

In the Assessment, energy efficiency (and other DERs, including demand response) reduces the Unrestricted Non-coincident Peak to the total internal demand, which is the denominator for the anticipated and prospective reserve margin metrics. All else being equal (i.e. for a given set of supply-side resources), this results in higher reserve margin ratios than a reserve margin ratio without efficiency and other DERs.

NERC collects data within and across eight regional entity boundaries that are based on existing ISO/RTO footprints. In 2018, there were 21 assessment areas (NERC, 2018). As part of the Assessment, NERC

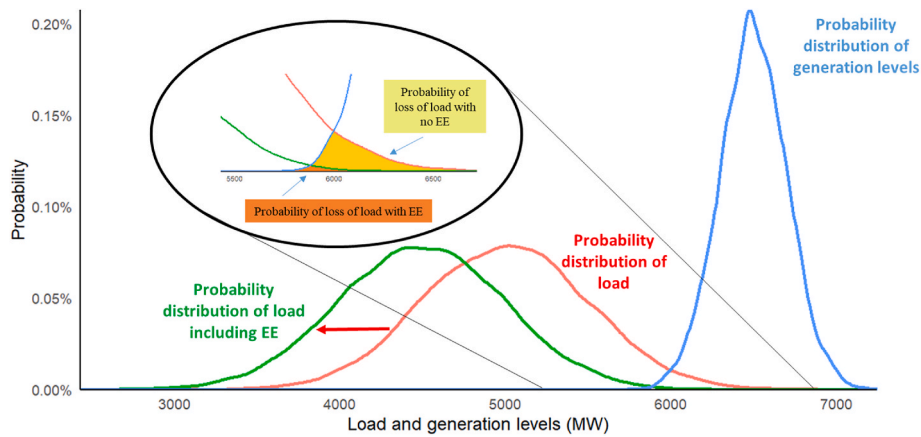

Fig. 3. Conceptual probability distribution for generation and load, illustrating the concept of LOLP.

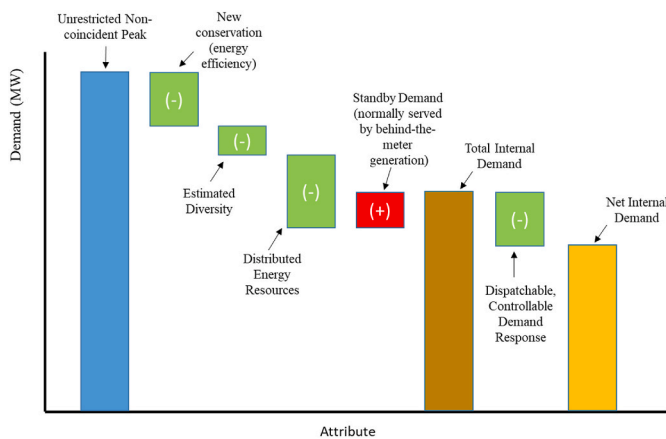

Fig. 4. Qualitative visualization of demand attributes considered in NERC Long-Term Reliability Assessment (authors creation based on NERC (2018)).

conducts a risk determination of each assessment area’s planning reserve margin by comparing the anticipated reserve margin to the reference margin level. If the former is higher than the reference margin level, NERC deems the system as adequate. Increased energy efficiency would result in higher anticipated planning reserve margins and hence a system with reduced risk.

3.2. Northwest Power and Conservation Council (probabilistic modeling approach)

The Northwest Power and Conservation Council is a regional planning entity in the Pacific Northwest. The Council is statutorily required to develop, with broad citizen participation, a regional power plan. The Council develops a 20-year regional power plan every five years. Its objective is to set forth a resource strategy that ensures an “adequate, efficient, economical and reliable power supply” at the lowest cost.

Each year the Council assesses the adequacy of the Northwest power supply over the next five years in its Power Supply Adequacy Assessment, based on its 5% annual LOLP adequacy standard (Northwest Power and Conservation Council, 2011). In this case, the LOLP reflects the likelihood of one or more curtailment events occurring during an operating year. Curtailment occurs when load exceeds generation after accounting for the contribution of “standby resources” – emergency resources that system operators can access to prevent curtailment such as demand response and small generators. The standard requires that the probability of a future year experiencing one or more curtailment events must be 5% or less. The Council’s LOLP analysis is a “chronological

hourly simulation of the power system’s operation over many uncertain conditions, including water supply, temperature (load variation), wind and solar generation and resource forced outages.” The assessments assume existing resources only and that targeted levels of energy efficiency are achieved (e.g., as identified in the most recent Power Plan). The Council finds that efficiency is key to maintaining adequate supplies of power in the near term (Northwest Power and Conservation Council, 2019).

The plan guides resource decision-making by the Bonneville Power Administration (BPA). BPA must submit for Council approval any new BPA energy resource acquisition greater than 50 average megawatts and acquired for more than five years, including energy efficiency. The Council’s regional power plan also serves as a reference document for the region’s public and investor-owned utilities, state regulatory commissions, and state energy offices.

3.3. Benefits of conservation for reliability and resilience in operation timeframes

Long-term planning and other resource adequacy processes are intended to minimize the chances of customers experiencing power disruptions. However, hazards that stress the power system beyond its design limitations are increasing in frequency and magnitude. Conservation is conceptually different from energy efficiency because it requires consumers to use less energy for a lesser service, whereas efficiency provides the same (or higher) level of service with less energy. Three examples illustrate how, in these situations, system operator calls for emergency conservation have prevented the power system from larger-scale blackouts that would take weeks to solve.

First, in summer 2020, California experienced extreme heat waves, characterized by several days of geographically widespread high temperatures that increased space conditioning demand and affected generation and transmission efficiency. Calls for voluntary conservation by the California Independent System Operator (CAISO), California Public Utilities Commission, utilities and community choice aggregators were critical to reducing rolling outages (CAISO, 2021).

Second, the International Energy Agency (IEA) published reports in 2005 and 2011 that focused on using conservation¹ to address electricity shortfalls due to a variety of unexpected, widespread and long-duration events (e.g., events that pose threats to resilience) (Pasquier, 2011). The 2011 report identified five tools to manage electricity shortfalls and provided examples of energy reductions during events that threaten grid

¹ Technically, the tools identified by the IEA are a mix of conservation, energy efficiency, and demand response interventions. However, we follow the IEA’s labeling and present them as conservation measures.

resilience: (1) Price signals: time-of-use, real-time pricing, critical-peak pricing; (2) behavior change: using public awareness and requests to voluntarily reduce electricity consumption; (3) technology replacement: lighting, appliance and equipment replacement; (4) rationing: voluntary and mandatory rationing, load shedding and load control; and (5) market mechanisms: allowing users to trade load reductions and price-induced conservation.

Finally, [Meier \(2005\)](#) focused on examples of using conservation to meet temporary shortfalls in electricity supply. It includes examples from eight countries where demand was reduced by 0.5–20%. The duration of conservation ranged from 1 day to 10 months in the examples.

4. Evaluation of efficiency's reliability benefits in distribution system planning

Distribution system planning assesses needed physical and operational changes to the local grid. Utilities use annual distribution planning processes to identify and define distribution system needs, identify and assess possible solutions, and select projects to meet system needs ([Schwartz and Homer, 2020](#)). Some distribution capacity expansion needs for reliability can be deferred, mitigated, or avoided by using DERs as NWA (also called non-wires solutions) ([Frick et al., 2021](#); [Chew et al., 2018](#)). The U.S. EPA has also recognized the ability of efficiency to improve “the reliability of the electricity system and lowering the risk of blackouts, particularly when load is reduced in grid-congested areas” and identifies efficiency's transmission and distribution benefits to include “increased reliability and improved power quality” ([EPA, 2018](#)).

States and utilities are beginning to identify NWAs that can address reliability needs, although they may not provide guidance on how to quantify that value. For example:

- In Maine, the definition of NWA includes reliability as one of its purposes. “Nonwires alternative means a non-transmission alternative or an infrastructure, technology or application that defers or reduces the need for capital investment in the transmission and distribution system and addresses system reliability needs proposed to be met by the transmission or distribution system investment” (35-A M.R.S §3131 (4) (c)) ([Maine Revised Statute, 2019](#)).
- Nevada requires a locational net benefit analysis (LNBA) as part of a utility's distribution system plan. The LNBA is defined as “a cost-benefit analysis of distributed resources that incorporates location-specific net benefits to the electric grid.” ([Nevada Administrative Code 704.9109](#)). The analysis is used to: (1) evaluate the economics of deploying distributed resources at different locations on the electric system, (2) evaluate the potential of distributed resources to defer traditional infrastructure upgrades, (3) understand the impact of distributed resources on long-term system needs related to load growth and reliability, and (4) inform the procurement process for non-wires solutions. The Public Utilities Commission of Nevada requires that “reductions to or increases in the reliability benefits of the electric grid” be considered when conducting an LNBA ([Nevada Administrative Code 704.9237](#)).
- Rochester Gas and Electric, an investor-owned utility in New York, identified that “NWA solutions utilize third-party Distributed Energy Resources (DERs) to postpone certain traditional construction projects needed primarily to correct system overloading conditions and, in some cases, system reliability issues. Other utilities in New York include reliability and resilience benefits in their benefit-cost analysis, discussed in the next section.

There are many examples of NWA including energy efficiency in the analysis ([Frick et al., 2020](#)). The following examples highlight the use of efficiency to defer distribution system upgrades as part of an Integrated Distribution Plan (Xcel Energy), successful NWA project that relied heavily on efficiency to defer the distribution system need (Consolidated

Edison), and implementation of a process to consider NWA in distribution system planning (NV Energy).

4.1. Xcel Energy

Xcel Energy's 2020–2029 Integrated Distribution Plan for Minnesota discusses the utility's work to update methodologies and distribution avoided costs for energy efficiency, as well as several new energy efficiency analyses, as “important complements to our annual [distribution] planning analysis.” ([Xcel Energy, 2019](#)). The plan also discusses “geo-targeting” energy efficiency and demand response to defer distribution system capacity upgrades, including a pilot program in two communities to test the viability of a geo-targeting strategy to provide a reliable alternative to traditional capacity upgrades. The utility defines geo-targeting as “using energy efficiency and demand response to defer or avoid the need to invest in a traditional distribution solution (e.g., transformer).” ([Xcel Energy, 2018](#)).

4.2. Consolidated Edison

Consolidated Edison's Brooklyn Queens Demand Management program uses targeted energy efficiency and distributed generation—combined heat and power (CHP), fuel cells, and battery energy storage—to provide load relief in specific networks in Brooklyn and Queens. In addition to 52 MW of load relief already achieved, another 11 MW of additional relief was planned to be installed by the end of 2021. Energy efficiency projects have focused primarily on lighting, with incentive amounts and installation support varying by customer class ([Consolidated Edison, 2019](#)). For CHP, the utility offered up to \$1800 per kW, with a cap at \$1.5 million per project.

For fuel cells, the utility matched New York State Research and Energy Development (NYSERDA) incentives up to \$1000 per kW, with an aggregate project cap of \$1 million. This matching program remained active through NYSERDA through the end of 2019. For both CHP and fuel cells, Consolidated Edison identified target zones and years projects were needed to guide development and offered an additional 25% incentive bonus on top of \$1000 per kW for projects that alleviated constraints by meeting locational and temporal criteria ([NYSERDA, 2019](#)). For battery energy storage, the utility offered \$2100/kW for selected customers in designated neighborhoods in Brooklyn and Queens whose systems could meet a minimum 4-h consecutive dispatch and be in operation by June 1, 2020.

4.3. NV energy

In 2017, the Nevada Legislature passed legislation requiring utilities to submit a Distributed Resource Plan (DRP) to the Public Utilities Commission of Nevada by July 2019, and every three years thereafter, as part of its resource plan ([Nevada Revised Statutes, 2017](#)). Among other provisions, the legislation requires that DRPs evaluate locational benefits and costs of distributed resources (distributed generation systems, energy efficiency, energy storage, electric vehicles, and demand response technologies). In 2019, the Public Utilities Commission of Nevada approved final regulations (Docket 17–08022) specifying DRP requirements for, among other things, NWA analysis, and locational net benefit analysis.

NV Energy considered three NWA projects to address reliability needs in its DRP ([Table 2](#)). The traditional upgrade projects would address unplanned contingencies by installing a second transformer at an existing substation. The transformer would be used to support load on the substation in the event the first transformer were to go out of service. The utility considered a combination of energy efficiency, demand response, solar photovoltaics and batteries for NWAs, sized to serve load on a continuous basis (as the second transformer would). Ultimately, NV Energy chose traditional solutions to meet these reliability needs because they were less costly, in part because the NWA was required to

Table 2

NV Energy forecasted distribution system constraints and potential NWA solutions (NV Energy, 2019).

Year	Substation	NWA Capacity in 2025 (kW)				NWA Energy Storage in 2025 (kWh)		Direct Cost (\$millions)	
		EE	DR	PV	Battery	Battery		NWA	Traditional Upgrade
2020	Silver Springs	140	0	7200	6610	88,960		55.2	3.2
2022	Ray Couch	200	0	0	2800	18,670		9.5	1.7
2025	Golconda	40	0	2600	2100	36,000	21.9		2.2

serve load on a continuous basis equivalent to that of a redundant transformer and resulting in the NWA projects being cost prohibitive. While the NWAs were not selected, this example does provide a framework for considering efficiency (or other DERs) as resource that can meet reliability needs.

5. Evaluation of efficiency's reliability benefits in demand-side management planning

DSM planning typically identifies energy efficiency and demand response potential and designs programs and implementation plans. DSM planning typically involves a benefit-cost analysis (BCA), a framework that allows for explicit recognition of benefits for demand side interventions to capture potential resilience and reliability benefits.

A monetary metric that can be used to measure the reliability impact on customers is the value of lost load (VOLL). The VOLL is traditionally measured through customer interruption cost (CIC) surveys that treat residential, commercial, and industrial customers separately. CIC surveys, by themselves, are considered inadequate to measure the economic impacts of long-duration interruptions or resilience events due to the customer's inability to quantify the cost of an interruption at a scale they have not experienced before (Baik et al., 2021). In lieu of such surveys, regional economic models are employed to obtain suitable values. In either case, calculating credible values for the VOLL is challenging, which has hampered the application of a value-based approach to reliability in long-term planning. Even if calculating values for VOLL was straightforward, an additional challenge would arise in applying heterogeneous customer-level VOLL values to a system-level cost function.

Reliability improvements for demand-side management planning are explicitly considered in efficiency BCA in five states—Arizona, Connecticut, Massachusetts, New York, and Rhode Island (NESP, 2021).

The Arizona Administrative Code's cost-effectiveness clause states that "The analysis of a DSM program's or DSM measure's cost-effectiveness may include: 1. Costs and benefits associated with reliability, improved system operations, environmental impacts, and customer service." (Arizona Administrative Code R.14-2-2412). The code requires that cost-effectiveness be measured using the Societal Cost Test, but does not provide guidance on how the utility should identify, quantify, and monetize the reliability benefits of DSM measures.

In Massachusetts, the Three-Year Energy Efficiency Plan states that "energy efficiency continues to play an important role in reducing customer demand, and has a positive impact on system reliability." (Mass Save, 2018, p. 14) The plan highlights how investments in weatherization and high efficiency heating equipment improve electric and gas winter reliability. The plan highlights passive housing as it "[...] offers the ultimate goal in high efficiency design; a building that uses little or no energy with additional resiliency benefits." (Id., p. 33).

Connecticut, Massachusetts and Rhode Island use the Avoided Energy Supply Components in New England (AESC) estimates of reliability benefits of efficiency from increased generation reserves, reduced thermal stress on transformers and conductors (reducing failures) and decreased probability of overloading transmission and distribution (T&D) equipment in their efficiency BCAs (Knight et al., 2021). Using a VOLL of \$73/kWh and an average usage of 1.6 kWh/customer-hours, the AESC estimates that resources that reduce stress in T&D equipment in New England produce a benefit of about \$1/megawatt-hour. The

report does not provide an estimate of the resilience benefits of efficiency interventions.

The New York Benefit Cost Analysis (NY-BCA) handbooks recognize two reliability/resiliency categories (New York Department of Public Service, 2015). The first is the net avoided restoration costs, which capture the benefits of measures that reduce the cost of restoring power after an outage. However, the handbooks indicate that most DERs, including energy efficiency, cannot accrue this benefit because utilities are required to fix the outage cause regardless of whether customers can satisfy some or all of their energy needs through efficiency or other DERs. In this case, the narrow definition of "restoration" as electricity flowing through the utility grid, rather than customers satisfying end uses or needs, prevents further recognition of resilience benefits from efficiency and other DERs. The second reliability/resiliency category recognized by the NY-BCA handbooks is the net avoided outage costs. The approach for estimating avoided outage costs relies on the VOLL, the average customer demand and the changes in SAIDI due to an intervention. The handbook is not explicit about how energy efficiency or other DERs accrue benefit from changes in SAIDI due to an intervention. However, efficiency can reduce the average customer demand, but it is not clear how the benefit is being used for efficiency in New York.

In addition, DSM plans are increasingly including using energy efficiency and other DERs to improve distribution system reliability and resilience. For example, in its 2021–2022 DSM plan for Colorado, Public Service of Colorado (PSCO) discusses its geo-targeting pilot to defer the need for investment in a new distribution transformer and associated feeder upgrades (Colorado Public Utilities Commission, 2020). The utility selected the project because (1) the deferred benefit is large enough to justify incremental spending on efficiency and demand response (the upgrade is estimated to cost more than \$10 million), (2) there is enough lead time to allow PSCO to implement targeted efficiency and demand response programs, and (3) traditional solutions, such as switching demand from a feeder that is approaching its thermal limit to a nearby feeder that is not, can be used to protect reliability during the pilot if needed.

PSCO is conducting a pilot to keep feeder levels below their thermal limits while new housing developments are being constructed. The project goal is to acquire 3 MW of load reduction by 2023. The utility is using targeted approaches to market to home builders existing energy efficiency program offerings, such as incentives for air-conditioning and ENERGY STAR homes, in tandem with demand response programs. For example, a builder can receive a rebate for installing a smart thermostat in a new home from both efficiency and demand response programs to reduce the incremental cost of the thermostat to zero.

6. Discussion: technical challenges and regulatory opportunities to incorporate reliability and resilience benefits and go beyond current practices

In this section, we discuss challenges with existing metrics and assessment methods that do not fully capture the reliability and resilience benefits of energy efficiency and present opportunities for technical and regulatory approaches to improve their valuation.

6.1. Challenges with existing reliability metrics

In all electricity system planning processes—BPS, distribution system, and DSM—the traditional metrics used to measure reliability hinder the recognition of reliability benefits of energy efficiency. In addition, in DSM planning, the methods used to monetize reliability benefits in BCA do not often capture the benefits of energy efficiency. Traditional reliability metrics such as SAIDI and SAIFI were designed to provide a system-level (or sometimes feeder-level) measurement of the total duration and frequency of interruptions averaged over all utility customers. These metrics provide a useful and easy way for regulators to monitor and enforce the reliability performance of utilities. However, these metrics only reflect the *availability* of power to customers; they do not reflect (1) the actual impact of interruptions on the consumption or fulfillment of end-use services and (2) the reliability experienced by *each individual customer*.

The standard IEEE 1366–2012 introduced two customer-centric reliability metrics: Customers Experiencing Long Interruption Durations (CELID) and Customers Experiencing Multiple Interruptions (CEMI). At least ten U.S. states and several utilities have adopted CEMI reporting (Watts et al., 2020). Grid Strategies developed a customer-centric framework for resilience that includes energy efficiency and distributed generation and storage at customer premises (Silverstein et al., 2018). Their proposal includes metrics similar to the CELID and CEMI. However, these standards are focused on counting customers suffering certain types of interruptions, rather than measuring the reliability experience of each customer individually. Hence, the challenges of recognizing the reliability benefits of customer-deployed energy efficiency remain as with the aggregate system-level metrics. The lack of individual customer reliability metrics (rather than aggregate customer metrics) means that there is no available framework to compare whether it is more cost-effective for reliability enhancements to deploy energy efficiency and other DER interventions or to upgrade the distribution system.

A recent report by Synapse and Sandia National Laboratories proposes customer-level performance metrics for resilience, including for customer and geographic subsegments, supplementing annual event-level and system-level metrics (Kallay et al., 2021a). In addition, metrics such as “passive survivability” and “hours of safety”—customer-level resilience benefits—have been proposed to track capability of buildings to maintain indoor air temperature within safe levels during heat waves or cold snaps. A well-insulated and highly efficient house can maintain indoor temperature during relatively short duration power interruptions (Sun et al., 2021), but this benefit is not reflected in any traditional resilience metric. An ongoing DOE-funded project is developing a standardized methodology to value energy efficiency and other DER technologies for energy resilience of buildings under extreme heat or cold events with power outages.²

Further, NWA approaches recognize the benefits of energy efficiency for the distribution system, but do not capture direct reliability benefits for individual customers whose homes and businesses are hosting these measures. Since traditional system-level reliability metrics obscure the heterogeneity of the actual interruptions experienced by customers, NWA assessments that use these metrics will not capture these differences across customers. Customer-level metrics would (1) identify highly-valued or critical end-uses (2) ensure that these end-uses can be consumed at least at minimum sustainable levels, and (3) ensure that service for each customer meets a minimum reliability standard with recognition of their level of vulnerability and adaptability. These customer-level metrics would enable societally efficient investment decisions in customer- or utility-facing resources to meet such standards.

² Personal communication with Tianzhen Hong on *Valuation of Energy Efficiency for Energy Resilience* research on October 13, 2021. The final report will be complete in spring 2022.

The third version of Consolidated Edison’s (ConEd) Electric Benefit Cost Analysis handbook recognizes this limitation: “Other reliability metrics will need to be developed to more suitably quantify reliability or resiliency benefits and costs associated with localized projects or programs” (Consolidated Edison, 2020, p. 31). Customer-level (or demand-side) reliability metrics are particularly important when approaching reliability from an energy justice perspective to ensure that *unreliability and poor building/community resilience are not inequitably distributed across customers* (Carvallo et al., 2021b; Baker, 2019; Farley et al., 2021).

BCA frameworks use the VOLL to monetize the benefits of increased reliability (or, equivalently, reduced unreliability). The examples of BCA reviewed in this paper reflect several challenges:

- *The VOLL typically reflects the cost of energy not served to customers, instead of costs of the consequences that accrue to customers and society as a whole during interruptions.* The use of retail rates to calculate the VOLL substantially underestimates the VOLL for all customer segments. For example, the NY-BCA handbook allows utilities to use the retail rate as the VOLL, effectively valuing lost load at 10–20 cents per kWh. In contrast, a properly calculated VOLL using CIC surveys as in New England’s AESC produces values of 73 dollars per kWh, about 300–700 times higher.
- *States that require the use of a VOLL for BCA limit it to a single value per customer segment, which does not capture heterogeneity across customers and interruption types.* In reality, the VOLL is highly dependent on their memories of and experiences with outages, on individual customer preference, their location, and the duration of the interruption (LaCommare et al., 2018).
- *Current VOLL approaches are generally not time sensitive, assigning the same value to load lost at any time of day and season.*
- *The calculation of VOLL is often based on short-duration outage data, limiting its application to resilience.* None of the BCA frameworks we reviewed measure or monetize resilience benefits of energy efficiency or DERs more generally. For example, the load lost in extreme weather events such as Winter Storm Uri in Texas is not captured in traditional VOLL measures. This event left 210 dead and caused estimated \$80–\$130 billion in economic damage (Donald, 2021).

6.2. Challenges with resilience metrics

The main challenge with resilience metrics is that they are nascent and not yet widely adopted. DOE’s efforts to develop and implement metrics will contribute toward better-informed investment and operational decisions to maintain or enhance resilience (Petit et al., 2020). Resilience metrics can broadly be considered in two categories: attribute-based and performance-based. Attribute-based metrics address the question, “What makes my system more/less resilient?” They can provide a baseline understanding of the system’s current resilience, relative to other systems. Performance-based metrics are quantitative approaches to answer the question, “How resilient is my system?” These approaches interpret quantitative data that describe infrastructure outputs for specified disruptions and assess infrastructure resilience (Vugrin et al., 2017). All of these metrics are focused on system- or grid-level analyses and likely would not capture the resilience benefits of customer-level energy efficiency, including by customer and geographic subsets. Recent research identifies ways that relevant resilience value can be identified and captured at the community and customer levels (Twitchell et al., 2020).

7. Conclusion and policy implications

7.1. Opportunities to improve quantification of efficiency’s reliability and resilience benefits

We offer the following recommendations for utilities and regulators to consider for improving the quantification of reliability and resilience

benefits of energy efficiency. Many of the recommendations focus on methodological advancements, bringing utilities' analyses in line with best practices. Others can be implemented as utilities adopt new technologies—for example, tapping the capabilities of advanced metering infrastructure to detect power outages at customer premises, instead of the feeder or substation level. Utilities can take advantage of these opportunities in their next integrated resource plan, distribution system plan, DSM plan, and grid modernization filing. State utility regulators can encourage methodological improvements by establishing clear principles and providing more explicit guidance on evaluating reliability and resilience (Kahrl and Schwartz, 2021). Specifically, regulators can develop or refine planning rules, establish consistent evaluation criteria across planning processes (where applicable), require that all available options be considered to meet electricity system needs, and, in orders on current utility plans, require utilities to make improvements in the next planning cycle.

1. Develop and use customer-level metrics to measure reliability and resilience. Research by Pacific Northwest National Laboratory finds that resilience benefits are fundamentally localized, and community- and customer-level metrics are necessary to identify cost-effective resilience investments by utilities and customers (Twitchell et al., 2020). Researchers identified five principles for a “locational planning framework”: (1) define critical loads, (2) identify major events of concern, (3) establish planning objectives, (4) engage in iterative planning between the project and the local grid to meet the needs of both, and (5) consider questions of ownership, cost allocation, and rate design. While the framework was developed for resilience value of energy storage, a similar framework could be used to identify and assess the resilience benefits of energy efficiency. The equitable distribution of efficiency's resilience benefits is an important consideration. Low-income households typically live in older, less-efficient buildings, with potential serious consequences during extreme weather events. Metrics can include data on customer energy burdens and building condition to support equity indicators for energy efficiency programs. More generally, state regulators can encourage or require utilities to develop, track, and report on customer-level metrics to better capture the full value of behind-the-meter energy efficiency interventions for both reliability and resilience.
2. Use better data and methods to monetize reliability. The limitations we identify in this paper with respect to using the VOLL to monetize reliability can be addressed with better data and methods. For example, Berkeley Lab recently developed a hybrid approach to assessing the VOLL and calculating customer, utility, and economy-wide impacts of widespread, long-duration interruptions by combining CIC surveys and macroeconomic models (Baik et al., 2021). Utilities can use time-sensitive VOLL in tandem with the time-sensitive value of energy efficiency will better capture the reliability and resilience benefits of energy efficiency.
3. Improve traditional VOLL approaches through development and use of a framework to quantify DER resilience benefits for the BPS. The National Renewable Energy Laboratory recently created a framework to quantify resilience benefits in a BPS planning process using duration-dependent customer damage functions that improve on traditional approaches (Anderson et al., 2021). Customer damage functions expand the concept of the VOLL by adjusting the value depending on duration, season, and time of day, among other factors. Least-cost investment decisions can then account for resilience impacts on customers reflected in the damage functions. Utilities could apply such customer damage functions to assess the resilience benefits of energy efficiency. In addition, utilities can use assessments of the economic damage for customers of existing long duration outages such as the Texas Winter Uri or the California Public Safety Power Shutoff events to improve their customer damage functions.

4. Strengthen BCA frameworks and expand their application. BCA frameworks can capture the benefits of efficiency on a wide array of dimensions, including reliability and resilience. However, reliance on imperfect VOLL definitions, lack of rigorous guidelines for measurement of efficiency impacts on reliability and resilience, and lack of quantification of resilience benefits are clear areas for improvement.³ Sandia National Laboratories and Synapse recently produced a BCA framework that explicitly recognizes resilience as a key goal when planning grid investments (Kallay et al., 2021b). While their framework does not especially focus on energy efficiency investments, it suggests several resilience benefits that regulators and utilities can investigate further for valuation and monetization.⁴ Many efficiency measures provide ongoing benefits by reducing demand year-round, not just during the peak hour or top demand hours of the year. Instead of simply evaluating annual or seasonal values, state regulators could support more complete quantification of efficiency's reliability and resilience contributions to electricity systems by encouraging or requiring greater consideration of the time-sensitive value of efficiency in BCAs (Frick and Schwartz, 2019).
5. Treat energy efficiency as a resource, and consider its time-sensitive value, in long-term BPS planning. Some improvements to quantifying the reliability and resilience benefits of energy efficiency may require broader changes to BPS planning processes. Recent Berkeley Lab research identifies asymmetries in the way energy efficiency and supply side resources are assessed in BPS planning processes (Frick et al., 2020). Utilities' limited use of energy efficiency as a selectable resource suggests that the reliability contributions of efficiency to the BPS are often not adequately captured. Utilities can model energy efficiency on a par with supply side resources to appropriately consider its time-sensitive value 8760 h a year and support quantification of efficiency's contributions to BPS reliability and resilience. Furthermore, utilities can improve this assessment by developing time-sensitive and cost-specific supply curves for energy efficiency that parallel the way traditional supply-side resources are represented in least cost planning models.
6. Integrate energy efficiency with other DERs. Analyzing the interactions of energy efficiency with other DERs in BPS planning models is important for accurate valuation of efficiency's value for reliability (State and Local Energy Efficiency Action Network, 2020). In addition, energy efficiency coupled with smart controls and other demand flexibility measures can promote resilience by helping to prevent outages and speed outage recovery time. Higher levels of DERs increases the need to address interactions of DERs with one another and with the electric grid. As a first step, utility analysis should capture major interactions between pairs of DERs, such as those that are likely to occur between energy efficiency and demand response. Accounting for DER interactions helps align planning estimates of impacts (amount, timing, and expected useful lives)—for valuation and cost-effectiveness screening—with actual impacts estimated through ex post assessments.
7. Design, measure, and value conservation and load shedding as resilience strategies and compensate them accordingly. Significant resilience benefits can accrue from emergency conservation measures. For example, the August 2020 California heat wave and February 2021 Texas storms would have caused significantly higher

³ The Northwest Power and Conservation Council's Regional Technical Forum recently issued a Request for Proposals for a resiliency valuation study from efficiency measures. <https://rtf.nwccouncil.org/sites/default/files/RFP-2022ValuationStudies.pdf>.

⁴ Synapse and Berkeley Lab developed a framework for navigating BCA for utility grid modernization plans, including consideration of resilience benefits (Woolf et al., 2021).

damage without voluntary energy efficiency measures and involuntary load reductions (CAISO, 2021; Busby et al., 2021). In August 2020, “For the third consecutive day, the California Independent System Operator (ISO) said consumer conservation efforts had averted rotating power outages” (CAISO, 2020). Because these are not programmatic energy efficiency interventions, their contribution to system resilience is typically not formally measured or valued, and there is limited information on compensating consumers for reducing load as a resilience strategy. This may be changing. For example, California Governor Newsom recently signed a Proclamation of a State of Emergency that requires the state Department of Finance to provide payments to utilities to compensate large energy users for reducing their electricity during extreme heat events (California Office of Governor Gavin Newsom, 2021). State regulators can investigate the use of conservation and load shedding to improve electricity system resilience, as well as potential compensation strategies that leverage existing non-price-triggered demand response programs for contingency load shedding.

8. Track improvement in restoration time as a reliability benefit of energy efficiency. Some BCA frameworks track improvements in restoration time as a reliability benefit of DERs, but they do not identify energy efficiency impacts on restoration time. In calculating net avoided restoration costs, utilities and regulators could account for potential improvements in restoration time due to lower loads caused by energy efficiency interventions. Lower loads could allow more customers to be supported by alternate circuits when a distribution segment is unavailable. This would lead to either reduced interruption time for customers that are transferred to a backup circuit or to overall reductions in average restoration time for customers in an affected area. State regulators can encourage or require utilities to develop, track, and report on customer-level metrics to better capture the full value of behind-the-meter energy efficiency interventions for reliability, including tracking improvements in restoration time.

7.2. Technical and regulatory research needs

This paper highlights challenges and opportunities for fully recognizing the potential contributions of energy efficiency for meeting reliability standards and improving customer, community, grid, and economy-wide resilience, as well as ways to address these challenges. Additional research is needed in many of these areas for regulators and policy makers to support decisions to pursue the opportunities outlined before.

1. Identify the potential of strategically designed efficiency and integrated DER portfolios to improve system reliability and resilience. Future research should identify commonly deployed energy efficiency measures and integrated DER portfolios and simulate (1) the reliability impacts at the BPS and distribution system levels using traditional metrics, (2) the reliability impacts from the customer perspective using newly developed metrics, and (3) the resilience impacts for customers, communities, grids, and economy-wide. For example, energy efficiency can decrease the scale of backup generation and storage required, reducing capital costs for hardening infrastructure. More generally, the way demand-side solutions may reduce the cost and risk of reliability and resilience improvements should be analyzed. In highly decarbonized futures with large electrification of end uses, joint analysis of energy efficiency and DER portfolios may help reduce renewable resource curtailment and reduce grid strain. This will be an important economic benefit going forward as more interest is directed at distributed generation plus storage as a resilience measure. Resilience analysis focuses on identifying hazards, vulnerabilities, and consequences that underpin relevant resilience metrics to measure the impacts of energy efficiency.

2. Consider the role of efficiency in resource adequacy. Fundamental changes in power system generation assets and widespread availability of flexible and controllable loads are challenging the traditional definition of BPS resource adequacy (ESIG, 2021). For example, a recent analysis for Texas found efficiency and DERs could play a critical role in ensuring resource adequacy if enhanced methods and metrics are used to assess and track it (Nadel et al., 2021).

These changes should be accompanied by research to understand what roles energy efficiency may play under new paradigms such as reliability events occurring outside of traditionally defined peak periods, increasing frequency and impacts of extreme weather events due to climate change, and increased dependence on weather resulting from increased amounts of renewable energy on the grid.

3. Continue developing improvements for long-term planning. Researchers have explored ways that long-term planning can be modified to incorporate resilience metrics. Valuing resilience is an emerging challenge for bid evaluation methods. Resilience is not calculated endogenously in traditional planning models. This research area is nascent and will require substantial development to understand how to incorporate customer, community, and economy-wide resilience into a power systems planning framework. Value-based reliability and resilience planning, which incorporates monetary interruption impact metrics into the least-cost planning exercise, also should be examined. This development could potentially radically transform the traditional “standard-based” approach to reliability planning and better align candidate resources with their expected reliability and resilience impacts.
4. Measure efficiency’s ability to reduce equipment failure rates. Reductions in load lead to less overloading of circuits and transformers (Zarei, 2017). Failure rates for transformers increase with more frequent and extreme overloading, both of which can be reduced by energy efficiency interventions (Zarei, 2017). The AESC report described earlier in this brief developed a simple method to estimate these failure rates, but further research is needed to properly measure the extent to which energy efficiency can reduce failure rates of transformers and how this benefit could be captured in a BCA framework.
5. Customer-level metric development and application. Two related areas of research are important for development of customer-level reliability and resilience metrics that capture energy efficiency benefits. First, research is needed to understand how utility decision-making would change if the utility faced customer-level, rather than system-level, reliability targets—even in the case of simple duration and frequency goals. For example, using customer-level targets could lead to an increase in adoption of NWA if achieving the targets is more cost-effective with local DERs rather than system-based solutions. A related challenge would explore how to design and integrate NWA with system-level solutions that enhance reliability and resilience. Second, research on customer-level metrics should explore how end-use and critical load-based metrics may be implemented and enforced, and the consequences of these metrics for utility decision-making and BCA frameworks.

Funding sources

The work described in this report was funded by the Strategic Analysis team of the U.S. Department of Energy’s Office of Energy Efficiency and Renewable Energy under Lawrence Berkeley National Laboratory Contract No. DE-AC02-05CH11231.

CRedit authorship contribution statement

Juan Pablo Carvallo: Conceptualization, Methodology, Visualization, Writing – original draft, Writing – review & editing. **Natalie Mims Frick:** Conceptualization, Methodology, Project administration, Writing

– original draft, Writing – review & editing, Funding acquisition. **Lisa Schwartz:** Conceptualization, Supervision, Writing – original draft, Supervision, Funding acquisition.

Declaration of competing interest

The authors declare that they have no known competing financial interests or personal relationships that could have appeared to influence the work reported in this paper.

Data availability

Data will be made available on request.

Acknowledgements

The authors thank Kristina Hamachi LaCommare, Berkeley Lab, for her contributions to this report and our U.S. Department of Energy (DOE) program manager, Ookie Ma, for his support of this project. We also thank him and DOE colleagues Ethan Epstein, Nichole Liebov, Michael Reiner, and Paul Spitsen for their review of the draft technical brief. We're grateful to Joseph Eto and Peter Larsen, Berkeley Lab, for reviewing an early draft. We also thank the following external experts for their review (affiliations do not imply that those organizations support or endorse this work): John Cornwall, Oregon Department of Energy; John Fazio, Northwest Power and Conservation Council; Jennifer Kallay, Synapse Energy Economics; Marty Kushler, American Council for an Energy Efficient Economy (ACEEE); Megan Levy, Wisconsin Office of Energy Innovation; Jonathon Monken, Converge Strategies; Caitlin Murphy, National Renewable Energy Laboratory; Grace Relf, Hawaii Public Utilities Commission; Julia Rotondo, Pacific Northwest National Laboratory; Adam Schultz, Oregon Department of Energy; Dan Shea, National Conference of State Legislatures; Alison Silverstein, consultant; Priya Sreedharan, GridLab; Hanna Terwillinger, Minnesota Public Utilities Commission; and Dan York, ACEEE. Finally, the authors benefited from the feedback from two anonymous reviewers who helped improve this article.

References

Aldieri, L., Gatto, A., Vinci, C.P., 2021. Evaluation of energy resilience and adaptation policies: an energy efficiency analysis. *Energy Pol.* 157, 112505 <https://doi.org/10.1016/j.enpol.2021.112505>.

Amann, J.T., 2006. Valuation of Non-energy Benefits to Determine Cost-Effectiveness of Whole-House Retrofits Programs: A Literature Review (No. A061).

Anderson, D., Kintner-Meyer, M., Eberle, A., Phillips, J., Edmunds, T., Porro, G., Eto, J. H., Shah, M., Folga, S., Silva-Monroy, C., Hadley, S., Vugrin, E., Heath, G., Yue, M., Tompkins, A., 2017. Grid Modernization: Metrics Analysis (GMLC1.1). Pacific Northwest National Laboratory.

Anderson, K., Li, X., Dalvi, S., Ericson, S., Barrows, C., Murphy, C., Hotchkiss, E., 2021. Integrating the value of electricity resilience in energy planning and operations decisions. *IEEE Syst. J.* 15, 204–214. <https://doi.org/10.1109/JSYST.2019.2961298>.

Arizona Administrative Code. Section 14-2-2412. Cost-Effectiveness. <https://casetext.com/regulation/arizona-administrative-code/title-14-public-service-corporations-corporations-and-associations-securities-regulation/chapter-02-corporation-commission-on-fixed-utilities/article-24-electric-energy-efficiency-standards/section-r14-2-2412-cost-effectiveness>.

Azar, Lauren, Elliot, Randolph, Aaronson, Scott, Givens, Sheri, 2019. Utility investments in resilience of electricity systems. Future Electric Utility Regulation report no. 11. <https://emp.lbl.gov/publications/utility-investments-resilience>.

Baik, S.H., Hanus, N.L., Sanstad, A.H., Eto, J.H., Larsen, P.H., 2021. A Hybrid Approach to Estimating the Economic Value of Enhanced Power System Resilience. Lawrence Berkeley National Laboratory. <https://emp.lbl.gov/publications/hybrid-approach-estimating-economic>.

Baker, S., 2019. Anti-resilience: a roadmap for transformational justice within the energy system. *Harv. Civ. Rights - Civ. Lib. Law Rev.* 54, 1–48, 2019, Northeastern University School of Law Research Paper No. 346-2019. <https://ssrn.com/abstract=3362355>.

Bartha, Paul, "Analogy and analogical reasoning", *The Stanford Encyclopedia of Philosophy* (Summer 2022 Edition), Edward N. Zalta (ed.), URL = <<https://plato.stanford.edu/archives/sum2022/entries/reasoning-analogy/>>.

Bie, Z., Lin, Y., Li, G., Li, F., 2017. Battling the extreme: a study on the power system resilience. *Proc. IEEE* 105, 1253–1266. <https://doi.org/10.1109/JPROC.2017.2679040>.

Busby, J.W., Baker, K., Bazilian, M.D., Gilbert, A.Q., Grubert, E., Rai, V., Rhodes, J.D., Shidore, S., Smith, C.A., Webber, M.E., 2021. Cascading risks: understanding the 2021 winter blackout in Texas. *Energy Res. Social Sci.* 77, 102106 <https://doi.org/10.1016/j.erss.2021.102106>.

Cagno, E., Moschetta, D., Trianni, A., 2019. Only non-energy benefits from the adoption of energy efficiency measures? A novel framework. *J. Clean. Prod.* 212, 1319–1333. <https://doi.org/10.1016/j.jclepro.2018.12.049>.

CAISO, 2020. Conservation needed earlier in day; Flex Alert issued for 2 to 9 p.m. Grid operator urges consumers to continue doing their part to keep power on. August 19. <https://www.caiso.com/Documents/Conservation-Needed-Earlier-Day-Flex-Alert-Issued-2to9pm.pdf>.

CAISO, California Public Utilities Commission, California Energy Commission, 2021. Root cause analysis: mid-august 2020 extreme heat wave. <http://www.caiso.com/Documents/Final-Root-Cause-Analysis-Mid-August-2020-Extreme-Heat-Wave.pdf>.

California Office of Governor Gavin Newsom, 2021. Proclamation of a state of emergency. In: <https://www.gov.ca.gov/wp-content/uploads/2021/07/Energy-Emergency-Proc-7-30-21.pdf>.

Caputo, S., Cascio, L., Jean-Baptiste, S., Tanner, C., Titus, E., 2017. Non-Energy Impacts Approaches and Values: an Examination of the Northeast, Mid-Atlantic, and beyond. *Northeast Energy Efficiency Partnerships*.

Carvallo, J.P., Zhang, N., Leibowicz, B.D., Carr, T., Galbraith, M., Larsen, P.H., 2021a. Implications of a regional resource adequacy program for utility integrated resource planning. *Electr. J.* 34, 106960 <https://doi.org/10.1016/j.tej.2021.106960>.

Carvallo, J.P., Hsu, F.C., Shah, Z., Taneja, J., 2021b. Frozen Out in Texas: Blackouts and Inequity. <https://www.rockefellerfoundation.org/case-study/frozen-out-in-texas-blackouts-and-inequity/>.

Channon, D.F., Sammut-Bonnici, T., 2015. Gap analysis. In: *Wiley Encyclopedia of Management*. John Wiley & Sons, Ltd, pp. 1–2. <https://doi.org/10.1002/9781118785317.wcom120109>.

Charmaz, K., 1996. Grounded theory. In: Smith, J.A., Harre, R., Van Langenhove, L. (Eds.), *Rethinking Methods in Psychology*. Sage Publications, London, pp. 27–49.

Chew, B., Myers, E., Adolf, T., Thomas, E., 2018. Non-wires alternatives: case studies from leading U.S. projects. E4 The Future.

Colorado Public Utilities Commission, 2020. DSM plan 2021-2022. https://www.dora.state.co.us/pls/efi/EFI.Show_Docket?p_session_id=&p_docket_id=20A-0287EG.

Consolidated Edison, 2019. Non-wires solutions. <https://www.coned.com/-/media/file/s/coned/documents/business-partners/business-opportunities/non-wires/con-edison-non-wires-webinar.pdf>.

Consolidated Edison, 2020. *Electric Benefit Cost Analysis Handbook v3.0*.

De Martini, P., Taft, J., Paladino, J., Kahrl, F., Kasina, F.S., Orans, R., 2020. Modern Distribution Grid, vol. IV. Prepared for U.S. Department of Energy. https://gridarchitecture.pnnl.gov/media/Modern-Distribution-Grid-Volume-IV_v1_0_draft.pdf.

EIS Council, 2021. Learn - EIS Council [WWW document]. EIS. URL <https://eiscouncil.org/learn/> (accessed 11.17.21).

Donald, J., 2021. Winter Storm Uri 2021: The Economic Impact of the Storm, Fiscal Notes. Texas Comptroller.

Energy Systems Integration Group, 2021. Redefining resource adequacy for modern power systems: redefining resource adequacy task force. <https://www.esig.energy/wp-content/uploads/2021/08/ESIG-Redefining-Resource-Adequacy-2021.pdf>.

EPA, 2018. https://www.epa.gov/sites/production/files/2018-07/documents/mbg_2-3_electricitysystembenefits.pdf.

Eto, J., 2016. How reliable is transmission compared to distribution and what do power interruptions really cost customers. In: (paper Presented at National Association of Regulatory Utility Commissioners Winter Committee Meeting, February 14–17, 2016).

Eto, J., Hamachi-LaCommare, K., Yue, M., 2020. Grid modernization: metrics analysis (GMLC1.1) – reliability. https://gmlc.doe.gov/sites/default/files/resources/GMLC1.1_Vol2_Reliability.pdf.

Farley, C., Howat, J., Bosco, J., Thakar, N., Wise, J., Su, J., Schwartz, L. (Eds.), 2021. *Advancing Equity in Utility Regulation*. Lawrence Berkeley National Laboratory. <https://emp.lbl.gov/publications/advancing-equity-utility-regulation>.

Francis, R., Bekera, B., 2014. A metric and frameworks for resilience analysis of engineered and infrastructure systems. *Reliab. Eng. Syst. Saf.* 121, 90–103. <https://doi.org/10.1016/j.ress.2013.07.004>.

Frick, N., Schwartz, L., 2019. Time-Sensitive Value of Efficiency: Use Cases in Electricity Sector Planning and Programs. Lawrence Berkeley National Laboratory. <https://emp.lbl.gov/publications/time-sensitive-value-efficiency-use>.

Frick, N., Eckman, T., Leventis, G., Sanstad, A., 2020. Methods to Incorporate Energy Efficiency in Electricity System Planning and Markets. Lawrence Berkeley National Laboratory. <https://emp.lbl.gov/publications/methods-incorporate-energy-efficiency>.

Frick, N., Price, S., Schwartz, L., Hanus, N., Shapiro, B., 2021. Locational Value of Distributed Energy Resources (No. DOE/LBNL-02012021, 1765585, Ark:/13030/qt6hc78827). <https://doi.org/10.2172/1765585>.

Gatto, A., Drago, C., 2020. A taxonomy of energy resilience. *Energy Pol.* 136, 111007 <https://doi.org/10.1016/j.enpol.2019.111007>.

IEEE Guide for Electric Power Distribution Reliability Indices, 2012. IEEE standard 1366. <https://ieeexplore.ieee.org/document/6209381>.

Kahrl, F., Schwartz, L. (Eds.), 2021. All-Source Competitive Solicitations: State and Electric Utility Practices. Lawrence Berkeley National Laboratory. <https://emp.lbl.gov/publications/all-source-competitive-solicitations>.

- Kallay, J., Napoleon, A., Havumaki, B., Hall, J., Odom, C., Hopkins, A., Whited, M., Woolf, T., Chang, M., Broderick, R., Jeffers, R., Garcia, B.M., 2021a. Performance metrics to evaluate utility resilience investments. Sandia National Laboratories. https://www.synapse-energy.com/sites/default/files/Performance_Metrics_to_Evaluate_Utility_Resilience_Investments_SAND2021-5919_19-007.pdf.
- Kallay, J., Letendre, S., Woolf, T., Havumaki, B., Kwok, S., Hopkins, A., Broderick, R., Jeffers, R., Jones, K., DeMenno, M., 2021b. Application of a standard approach to benefit-cost analysis for electric grid resilience investments. Sandia National Laboratories. https://www.synapse-energy.com/sites/default/files/Standard_Approach_to_Benefit-Cost_Analysis_for_Electric_Grid_Resilience_Investments_19-007.pdf.
- Knight, P., Chang, M., White, D., Hall, J., White, D., Frost, J., Havumaki, B., Odom, C., Bhandari, D., Lane, C., Hopkins, A., Kwok, S., Biewald, B., Chernick, P., Harvey, J., Deman, L., Rosenkranz, J., Gifford, J., Yuen, P., 2021. *Avoided Energy Supply Components In New England: 2021 Report*. Prepared by Synapse Energy Economics, Resource Insight, Les Deman Consulting, North Side Energy, and Sustainable Energy Advantage. AESC Study Group. https://www.synapse-energy.com/sites/default/files/AESC%202021_20-068.pdf.
- LaCommare, K.H., Eto, J.H., Dunn, L.N., Sohn, M.D., 2018. Improving the estimated cost of sustained power interruptions to electricity customers. *Energy* 153, 1038–1047. <https://doi.org/10.1016/j.energy.2018.04.082>.
- Larsen, P., Goldman, C., Gilligan, D., Singer, T., 2012. Incorporating Non-energy Benefits into Energy Savings Performance Contracts (No. LBNL-5519E). Lawrence Berkeley National Lab. (LBNL), Berkeley, CA (United States).
- Maine Revised Statute (M.R.S.) Section 35-A Public Utilities, (Chapter 31), Section 3131.4c. <http://legislature.maine.gov/legis/statutes/35-A/title35-Asec3131.html>.
- Mass Save, 2018. Massachusetts joint statewide electric and gas three-year energy efficiency plan 2019–2021. Mass Save. <https://ma-eeac.org/wp-content/uploads/2019-2021-Three-Year-Energy-Efficiency-Plan-April-2018.pdf>.
- Meier, A., 2005. Saving Electricity in a Hurry: Dealing with Temporary Shortfalls in Electricity Supplies. International Energy Agency. <https://iea.blob.core.windows.net/assets/4cb1d29e-1ecc-4f5c-950a-6b66e2073d9c/savingelec.pdf>.
- Mills, E., Rosenfeld, A., 1996. Consumer non-energy benefits as a motivation for making energy-efficiency improvements. *Energy* 21, 707–720. [https://doi.org/10.1016/0360-5442\(96\)00005-9](https://doi.org/10.1016/0360-5442(96)00005-9).
- Nadel, S., Gerbode, C., Amann, J., 2021. Energy efficiency and demand response: tools to address Texas' reliability challenges. ACEEE White Paper. https://www.aceee.org/sites/default/files/pdfs/energy_efficiency_and_demand_response_for_texas_10-13-21_final_0.pdf.
- NARUC, 2019. The Value of Resilience for Distributed Energy Resources: an Overview of Current Analytical Practices. Prepared by Converge Strategies LLC. <https://pubs.naruc.org/pub/531AD059-9CC0-BAF6-127B-99BCB5F02198>.
- National Academies of Sciences, Engineering, and Medicine, 2017. *Enhancing the Resilience of the Nation's Electricity System*. The National Academies Press. <https://doi.org/10.17226/24836>.
- Nehler, T., Rasmussen, J., 2016. How do firms consider non-energy benefits? Empirical findings on energy-efficiency investments in Swedish industry. *J. Clean. Prod.* 113, 472–482. <https://doi.org/10.1016/j.jclepro.2015.11.070>.
- NERC, 2018. ERO reliability assessment process document. In: <https://www.nerc.com/comm/PC/Reliability%20Assessment%20Subcommittee%20RAS%202013/ERO%20Reliability%20Assessment%20Process%20Document.pdf>.
- NERC, 2020a. 2020-2021 winter reliability assessment. November 2020. https://www.nerc.com/pa/RAPA/ra/Reliability%20Assessments%20DL/NERC_WRA_2020_2021.pdf.
- NERC, 2020b. 2020 long-term reliability assessment. https://www.nerc.com/pa/RAPA/ra/Reliability%20Assessments%20DL/NERC_LTRA_2020.pdf.
- 7.14.22 NESP, 2021, Home [WWW Document]. NESP. URL. <https://www.nationalenergyscreeningproject.org/>.
- Nevada Administrative Code. 704.9109. Locational net benefit analysis defined. <https://www.leg.state.nv.us/nac/NAC-704.html#NAC704Sec9109>.
- Nevada Administrative Code. 704.9237. Requirements and contents of distributed resources plan. <https://www.leg.state.nv.us/nac/NAC-704.html#NAC704Sec9237>.
- Nevada Revised Statute, 2017. SB 146. <https://www.leg.state.nv.us/App/NELIS/REL/79th2017/Bill/4982/Overview>.
- New York Department of Public Service, 2015. Staff white paper on benefit-cost analysis in the reforming energy vision, proceeding 14-M-0101. [https://www3.dps.ny.gov/W/PSCWeb.nsf/96f0fec0b45a3c6485257688006a701a/c12c0a18f55877e785257e6f005d533e/\\$FILE/Staff_BCA_Whitepaper_Final.pdf](https://www3.dps.ny.gov/W/PSCWeb.nsf/96f0fec0b45a3c6485257688006a701a/c12c0a18f55877e785257e6f005d533e/$FILE/Staff_BCA_Whitepaper_Final.pdf).
- Northwest Power and Conservation Council, 2011. A new resource adequacy standard for the Pacific Northwest. https://www.nwcouncil.org/sites/default/files/2011_14_1.pdf.
- Northwest Power and Conservation Council, 2019. Pacific Northwest power supply adequacy assessment for 2024. <https://www.nwcouncil.org/reports/pacific-northwest-power-supply-adequacy-assessment-2024>.
- Norton, R.A., Brown, B.W., Malomo-Paris, K., Stubblefield-Loucks, E., 2016. Non-energy benefits, the clean power plan, and policy implications for multifamily housing. *Green & Healthy Homes Initiative*.
- NYSEDA, 2019. Clean energy fund. Stationary fuel cell program. Summary of revisions. <https://portal.nyserda.ny.gov/servlet/servlet.FileDownload?file=00Pt000000CrRMSEA3>.
- Pasquier, S., 2011. Saving electricity in a hurry. International energy agency energy efficiency series. https://iea.blob.core.windows.net/assets/dd89096f-3676-4859-a34a-ef21331f18a1/Saving_Electricity.pdf.
- principal investigators Petit, F., Vargas, V., Kavicky, J., Kintner-Meyer, M., Eto, J., 2020. Grid modernization: metrics analysis (GMLC 1.1) – resilience. Prepared for U.S. Department of energy. https://gmlc.doe.gov/sites/default/files/resource/s/GMLC1.1_Vol3_Resilience.pdf.
- Pye, M., McKane, A., 2000. Making a stronger case for industrial energy efficiency by quantifying non-energy benefits. *Resour. Conserv. Recycl.* 28, 171–183. [https://doi.org/10.1016/S0921-3449\(99\)00042-7](https://doi.org/10.1016/S0921-3449(99)00042-7).
- Relf, G., Jarrah, A., 2020. *Measuring Three Rs of Electric Energy Efficiency: Risk, Reliability, and Resilience*. ACEEE.
- Rickerson, W., Gillis, J., Bulkeley, M., 2019. The value of resilience for distributed energy resources: an overview of current analytical practices. Prepared for the National Association of Regulatory Utility Commissioners. <https://pubs.naruc.org/pub/531AD059-9CC0-BAF6-127B-99BCB5F02198>.
- Rickerson, W., Zitelman, K., Jones, K., 2022. *Valuing Resilience for Microgrids: Challenges, Innovative Approaches, and State Needs*. National Association of Regulatory Utility Commissioners.
- Roege, P.E., Collier, Z.A., Mancillas, J., McDonagh, J.A., Linkov, I., 2014. Metrics for energy resilience. *Energy Pol.* 72, 249–256. <https://doi.org/10.1016/j.enpol.2014.04.012>.
- Schwartz, L., Homer, J., 2020. Distribution planning regulatory practices. Integrated Distribution System Planning Training for MISO/Midwest region. https://eta-publications.lbl.gov/sites/default/files/9_distribution_planning_regulatory_practices_fin2.pdf.
- Silverstein, A., Gramlich, R., Goggin, M., 2018. A customer-focused framework for electric system resilience. <https://gridprogress.files.wordpress.com/2018/05/customer-focused-resilience-final-050118.pdf>.
- State and Local Energy Efficiency Action Network, 2020. Determining utility system value of demand flexibility from grid-interactive efficient buildings. Prepared by: tom eckman, lisa schwartz, greg leventis. Lawrence Berkeley National Laboratory. <https://emp.lbl.gov/publications/determining-utility-system-value>.
- Sun, K., Zhang, W., Xeng, Z., Levinson, R., Wei, M., Hong, T., 2021. Passive colling designs to improve heat resilience of homes in underserved and vulnerable communities. *Energy & Buildings*. <https://www.sciencedirect.com/science/article/pii/S0378778821006678?via=ihub>.
- Tonn, B., Peretz, J.H., 2007. State-level benefits of energy efficiency. *Energy Pol.* 35, 3665–3674. <https://doi.org/10.1016/j.enpol.2007.01.009>.
- Twitchell, J.B., Newman, S.F., O'Neil, R.S., McDonnell, M.T., 2020. Planning considerations for energy storage in resilience applications. Pacific Northwest National Laboratory. <https://energystorage.pnnl.gov/pdf/PNNL-29738.pdf>.
- Vugrin, E., Castillo, A., Silva-Monroy, C., 2017. Resilience metrics for the electric power system: a performance-based approach. Sandia National Laboratories. <https://www.osti.gov/servlets/purl/1367499>.
- Watson, J.-P., Guttromson, R., Silva-Monroy, C., Jeffers, R., Jones, K., Ellison, J., Rath, C., Gearhart, J., Jones, D., Corbet, T., Hanley, C., Walker, L.T., 2014. Conceptual framework for developing resilience metrics for the electricity, oil, and gas sectors in the United States (No. SAND-2014-18019, 1177743). <https://doi.org/10.2172/1177743>.
- Watts, C., McCarthy, C., Levite, B., 2020. Moving beyond average reliability metrics. S&C Electric Company. <https://www.sandc.com/en/gridtalk/2020/july/21/moving-beyond-average-reliability-metrics/>.
- Wood III, P., Gee, R., Walsh, J., Perlman, B., Klein, B., Silverstein, A., 2021. Never again: how to prevent another major Texas electricity failure. <https://cgmf.org/blog-entry/436/FACT-SHEET-%7C-Never-Again-How-to-prevent-another-Texas-electricity-failure.html#:~:text=The%20recommendations%20include%3A&text=Higher%20energy%20efficiency%20building%20standards,for%20more%20granular%20outage%20management>.
- Woolf, T., Malone, E., Takahashi, K., Steinhurst, W., 2012a. *Best Practices for Screening Energy Efficiency Programs*. National Home Performance Council.
- Woolf, T., Steinhurst, W., Malone, E., Takahashi, K., 2012b. *Energy Efficiency Cost-Effectiveness Screening How to Properly Account for 'Other Program Impacts' and Environmental Compliance Costs*. Synapse.
- Woolf, T., Havumaki, B., Bhandari, D., Whited, M., Schwartz, L., 2021. *Benefit-Cost Analysis for Utility-Facing Grid Modernization Investments: Trends, Challenges, and Considerations*. Lawrence Berkeley National Laboratory. https://eta-publications.lbl.gov/sites/default/files/gmlc_bca_final_report_20210202.pdf.
- Xcel energy, 2020-2029 Integrated Distribution Plan, Nov. 1, 2019, at 59. Minnesota Public Utilities Commission Docket No. 19-666.
- Xcel energy, 2018. Q3-2018 Colorado DSM roundtable. <https://www.xcelenergy.com/sites/default/files/xe-responsive/Company/Rates%20&%20Regulations/Regulatory%20Filings/November-13-2018-Presentation.pdf>.
- Zarei, T., 2017. Analysis of reliability improvements of transformers after application of dynamic rating. School of Electrical Engineering at KTH Royal Institute of Technology. <http://kth.diva-portal.org/smash/record.jsf?pid=diva2%3A1155097&dsid=9080>.